

**A.G&S.G SIDDHARTHA DEGREE COLLEGE OF ARTS AND SCIENCE
(AUTONOMOUS), VUYYURU**



DEPARTMENT OF ENGLISH

**BOARD OF STUDIES MEETING
GENERAL ENGLISH**

VENUE

ENGLISH LANGUAGE LABORATORY

DATE



9th November, 2021

Minutes of the meeting of Board of Studies in General English for the Autonomous courses of AG & SG Siddhartha Degree College of Arts & Science, Vuyyuru, held through Google Meet on 09-11-2021 in the English Language Laboratory at 11.00 am.

Sri B.Bulli Babu

Presiding

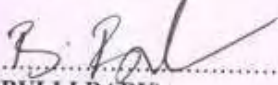
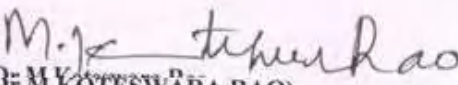
Members Present:

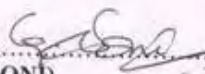
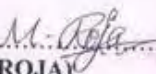
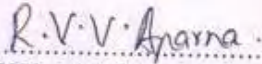
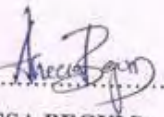
- 1) 
(B.BULLI BABU) Chairman Head, Department of English
AG & SG S Degree College
Vuyyuru-521165
- 2) 
(Dr.M.KOTESWARA RAO) University Professor,
Nominee Department of English
Krishna University,
Machilipatnam.
- 3) 
(Dr.G.SRI LATHA) Academic Council Head,
Nominee Department of English,
PBS College,
Vijayawada.
- 4) 
(Ms.G.SONI) Academic Council Lecturer in English,
Nominee GDC, Ravulapalem.
- 5) 
(M.ROJA) Member Lecturer in English
AG & SG S Degree College,
Vuyyuru-521165
- 6) 
(R.V.V.APARNA) Member Lecturer in English
A.G & S.G.S Degree College,
Vuyyuru-521165
- 7) 
(ANEESA BEGUM) Member Lecturer in English
A.G & S.G.S Degree College,
Vuyyuru-521165

**Agenda for B.O.S Meeting of General English for I & III SEMESTERS
for the Academic Year 2021-22**

The following proposals are submitted as a part of the agenda for the consideration and approval of the honorable members of Board of Studies, at the meeting held on 9th November, 2021.

1. To recommend syllabi for 1st and 3rd semesters of I & II Degree students of all disciplines for the Academic Year 2021-22.
2. To Consider and approve the additional inputs and minor modifications if any, in the I & III Semester papers of General English.
3. To recommend the Model Question Papers of 1st and 3rd semesters of I & II Degree of all disciplines for the Academic Year 2021-22.
4. To recommend the Guidelines to be followed by the question paper setters in General English for the 1st and 3rd semester-end exams of I & II Year students of all disciplines.
5. To recommend the teaching and evaluation methods to be followed under Autonomous status.
6. To recommend topics for online teaching and evaluation patterns.
7. To consider and approve the implementation of Pedagogy methods like Quiz, classroom seminar, Assignment or Case study, Test, puzzles, viva and few more innovative methods in classroom teaching as indicated in the curricular plans.
8. To consider and approve to arrange Guest Lectures by Subject Experts @ 1(minimum) per Semester rounded up to more than 3 per academic year.
9. Any suggestions regarding Certificate/Add-on Courses, Seminars, Workshops, Guest Lectures and student competitions to be organized.
10. To note any changes in the syllabus if made by APSICHE for the admitted batch of I Semester of the academic year 2021-22.
11. Any other matter.

RESOLUTIONS

1. Discussed and recommended the syllabus for 1st and 3rd semesters of I & II Degree students of all disciplines for the approval of the Academic Council.
2. Discussed and recommended the syllabi prescribed by APSCHE without any changes for 1st and 3rd semesters of I & II Degree students of all disciplines for the approval of the Academic Council.
3. Discussed and recommended the I & III Semester Model Question Papers of General English for the approval of the Academic Council.
4. Discussed and recommended the guidelines to be followed by the question paper setters of General English for 1st & 3rd Semesters of I & II year students of all disciplines for the approval of the Academic Council.
5. Discussed and recommended the teaching methodology to be taken up and the evaluation patterns to be done.

Teaching methods:

Besides the conventional methods of teaching (The Direct Method, The Structural Approach), Grammar-Translation Method, Audio-lingual Method, Communicative Language Teaching (CLT), Task-Based Language Learning etc., are practiced. We use modern technology i.e. using of an LCD projector, display on U boards, you tube videos etc., for better understanding of concepts.

There are two components in the Valuation and Assessment of a student – Internal Assessment (IA) and Semester Examinations (SE).

Internal Assessment (IA)

I SEMESTER

- The maximum mark for IA is 25 and SE is 75 for theory. Out of these 25 marks, 20 marks are allocated for announced tests.
- Each IA written examination is of 1 hour 30 minutes duration for 20 marks. The tests will be conducted centrally. The average of two such IA is calculated for 20 marks.
- Other Innovative Components will be for 5 Marks. The innovative component is for 5 marks, conducted during the class hours by the staff member/ in charge of the subject, in the form of assignments/ quiz/ seminars /presentations/Online/Open Book/Viva Voce/ Group work/ Mini Project/ Exhibition, etc. The topic and time for submission/ presentation will be announced by the staff member/ in charge of the subject in advance. Each student should explain and defend his/her presentation.
- There is no passing minimum for IA.

Semester Examinations (SE)

- A student should register himself/herself to appear for the Semester Examinations by payment of the prescribed fee.
- The Semester Examinations will be in the form of a comprehensive examination covering the entire syllabus in each subject. It will be of 3 hours duration, with maximum 75 marks, irrespective of the number of credits allotted to it.

- Even though the candidate is absent for two IA exams/obtain zero marks, the external marks are considered (if he/she gets 40/70) and the result shall be declared as 'PASS'.
- The pass mark shall be 30 out of 75 in the Semester end examination.
- The maximum marks for each Paper shall be 100.

III SEMESTER

- The maximum mark for IA is 30 and SE is 70 for theory. Out of these 30 marks, 20 marks are allocated for announced tests.
- Each IA written examination is of 1 hour 30 minutes duration for 20 marks. The tests will be conducted centrally. The average of two such IA is calculated for 20 marks.
- Other Innovative Components will be for 5 Marks. The innovative component is for 5 marks, conducted during the class hours by the staff member/ in charge of the subject, in the form of assignments/ quiz/ seminars /presentations/Online/Open Book/Viva Voce/ Group work/ Mini Project/ Exhibition, etc. The topic and time for submission/ presentation will be announced by the staff member/ in charge of the subject in advance. Each student should explain and defend his/her presentation. For attendance 5 Marks are allotted.
- There is no passing minimum for IA.

Semester Examinations (SE)

- A student should register himself/herself to appear for the Semester Examinations by payment of the prescribed fee.
 - The Semester Examinations will be in the form of a comprehensive examination covering the entire syllabus in each subject. It will be of 3 hours duration, with maximum 70 marks, irrespective of the number of credits allotted to it.
 - Even though the candidate is absent for two IA exams/obtain zero marks, the external marks are considered (if he/she gets 40/70) and the result shall be declared as 'PASS'.
 - The pass mark shall be 28 out of 70 in the Semester end examination.
 - The maximum marks for each Paper shall be 100.
6. Discussed and recommended the topics for online teaching to be taught and the evaluation patterns to be taken up.
 7. Considered and approved the implementation of Pedagogy methods like Quiz, classroom seminar, Assignment or Case study, Test, puzzles, viva and few more innovative methods in classroom teaching as indicated in the curricular plans.
 8. Considered and approved to arrange Guest Lectures by Subject Experts rounded up to 3 per academic year.
 9. Discussed and recommended to organize Seminars, Guest lectures, Workshops to enhance the knowledge of students besides conducting Certificate Course in Competitive English. It has been suggested that the Bridge Course may be conducted for the I year students before the commencement of regular classes. All these recommendations are forwarded for the approval of the Academic Council.
 10. Discussed and recommended to implement the 100% of the new syllabus introduced / made by APSCHE for the admitted batch of the I Semester for the academic year 2021-22. All these recommendations are forwarded for the approval of the Academic Council.
 11. Nil.

Signatures of the BOS Members:

Dr. M. KOTESWARA RAO
(University Nominee)

Dr. G. SRI LATHA
(Academic Council Nominee)

(Ms. G. SONI)
(Academic Council Nominee)

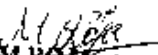
M. ROTA
(Member)

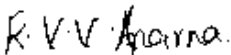
R. V. V. APARNA
(Member)

ANEESA BEGUM
(Member)

Chairman

**A.G & S.G SIDDHARTHA DEGREE COLLEGE OF ARTS AND SCIENCE,
VUYYURU – 521165**
(An Autonomous College in the Jurisdiction of Krishna University, Machilipatnam.)
Accredited with “A” Grade by NAAC, Bengaluru
Semester - I

ENGLISH PRAXIS COURSE-I
A COURSE IN COMMUNICATION AND SOFT SKILLS

Course Code	ENGT11B	Course Delivery Method	Class Room/ Blended Mode - Both
Credits	03	CIA Marks	25
No.of Lecture Hours / Week	4	Semester End Exam Marks	75
Total No.of Lecture Hours	60	Total Marks	100
Year of Introduction:	Year of Offering: 2021-22	Year of Revision: -----	Percentage of Revision: 0%
CLASS:	I YEAR DEGREE (ALL COURSES)		

Course objective:

The aim of this course is to improve the speaking skills of the learners in regard to the sound-spelling relationship of the language appears anarchic and to introduce the basic Grammar and Vocabulary as well as reading skills. Another problem that many Indian languages face is English Word Accent.

Course Outcomes:

By the end of the semester, the students can acquire linguistic competence to be able to compete with the globalised world and become successful in all the challenges that they face. On successful completion of the paper, the students are introduced to communicative skills, to define, classify, and understand the methods of communication, to improve their LSRW skills, to enable them to practice those skills in their daily life by identifying instances of communication in the circumstances of their own.

- Introduced the students to the speech sounds of English in order to enable them to listen to English and speak with global intelligibility
- Enabled the students to speak English confidently and effectively in a wide variety of situations.
- Helped the students to improve their writing efficiency by refining their writing strategies.

Learning Outcomes

By the end of the course the learner will be able to :

- Use grammar effectively in writing and speaking.
- Demonstrate the use of good vocabulary
- Demonstrate an understating of writing skills
- Acquire ability to use Soft Skills in professional and daily life.
- Confidently use the tools of communication skills

ENGLISH PRAXIS COURSE-I A COURSE IN COMMUNICATION AND SOFT SKILLS

SYLLABUS

Unit	Learning Units	Lecture Hours
I	Listening Skills 1. Importance of Listening 2. Types of Listening 3. Barriers to Listening 4. Effective Listening	10
II	Speaking Skills 1. Sounds of English: Vowels and Consonants 2. Word Accent 3. Intonation	10
III	Grammar 1. Concord 2. Modals 3. Tenses (Present/Past/Future) 4. Articles 5. Prepositions 6. Question Tags 7. Sentence Transformation (Voice, Reported Speech & Degrees of Comparison) 8. Error Correction	15
IV	Writing 1. Punctuation 2. Spelling 3. Paragraph Writing	10
V	Soft Skills 1. SWOC 2. Attitude 3. Emotional Intelligence 4. Telephone Etiquette 5. Interpersonal Skills	15

REFERENCES:

1. English praxis-I—A Course in communication and soft skills by S.B.Fathima Mary,Vivanta publishers2021
2. English praxis-I—A Course in communication and soft skills by Himalaya Publishing House 2021.

Suggested Co-Curricular Activities

1. Elocution
2. Group discussion
3. Essay Writing
4. Creative Writing
5. Recitation

**A.G & S.G SIDDHARTHA DEGREE COLLEGE OF ARTS AND SCIENCE,
VUYYURU – 521165**
(An Autonomous College in the Jurisdiction of Krishna University, Machilipatnam)
Accredited with “A” Grade by NAAC, Bengaluru

ENGLISH	ENGT11B	2021-2022	B.A,B.Com & B.Sc
----------------	----------------	------------------	-----------------------------

Time: 3 hours

Max Marks: 75

**The Pattern of the Question Paper for Semester – I: ENGT11B
Semester - I**

SECTION – A

I. Answer any FIVE of the following questions. 5 x 5 = 25M

(7 Paragraph questions should be given from UNIT – I (Listening Skills), UNIT-II (Speaking Skills) & UNIT – V (Soft Skills))

SECTION – B

II. Answer any FIVE of the following questions. 5 x 3 = 15M

(6 Paragraph questions should be given from UNIT – II (Speaking Skills) & UNIT-V (Soft Skills)).

SECTION – C (LANGUAGE ACTIVITY) 35 M

- III.** Fill in the blanks with suitable articles. 6 x ½ = 3M
- IV.** Fill in the blanks with suitable prepositions. 6 x ½ = 3M
- V.** Fill in the blanks with the correct form of verbs given in the brackets. 5 x 1 = 5M
- VI.** Fill in the blanks with suitable concord of the following sentences 6 x ½ = 3M
- VII.** Write the correct question tags for the following statements 3 x 1 = 3M
- VIII.** Fill in the blanks with suitable auxiliary verbs. 4 x ½ = 2M
- IX.** Write the spelling of the following misspelt words 4 x ½ = 2M
- X.** Punctuate the following sentences. 2x1=2M
- XI.** Rewrite the following sentences as directed. 5x1=5M
- XII.** Correct the following sentences. 2x1=2M
- XIII.** Write a paragraph on any ONE of the following. 1x5=5M

(Two topics should be given from UNIT – IV (Writing), from the topic of paragraph writing)

**A.G & S.G SIDDHARTHA DEGREE COLLEGE OF ARTS AND SCIENCE,
VUYYURU - 521165**
(An Autonomous College in the Jurisdiction of Krishna University, Machilipatnam.)
Accredited with “A” Grade by NAAC, Bengaluru

ENGLISH	ENGT11B	2021-2022	B.A,B.Com & B.Sc
----------------	----------------	------------------	-----------------------------

Time: 3 hours

Subject Code : ENGT11B

Max Mark: 75

Pass Marks: 30

Semester – I
A COURSE IN COMMUNICATION AND SOFT SKILLS – I

Model Question Paper

SECTION- A

I. Answer any FIVE of the following questions.

5 x 5 = 25M

1. Write vowel sounds with 3 examples each in three different positions. *CO2 LI*
2. Write all the consonants sounds with 3 examples in three different positions each. *CO2 LI*
3. Define intonation and describe the types of intonation with examples? *CO2 LI*
4. What is Emotional Intelligence and what are the tips to develop Emotional Intelligence?*CO5 LI.*
5. Write a note on different types of listening. *CO1 L4.*
6. What is attitude? What are the characteristics of Positive Attitude? *CO5 L*
7. What are the barriers to effective listening? *CO 1 L4*

SECTION –B

II. Answer any FIVE of the following questions.

5 x 3 = 15M

1. What is SWOC and what are the limitations of SWOC? *CO5 L2*
2. Explain any three stages of listening process.
3. What is intonation ? Give some examples.
4. What is etiquette? What are the examples of telephone etiquette? *CO5 LI*
5. Write a note on different types of listening. *CO1 L4*
6. Describe the traits of a good listener? *CO1 L2*

SECTION –C

III. Fill in the blanks with suitable articles.

CO3 LI

6 x ½ = 3M

If we ask____(1) audience to reproduce what they have just heard in____(2) presentation, we may often receive different versions of____(3) same speech. This happens each member of____(4) audience listens differently. Each individual hears____(5) message from his/her point of view and contextualizes

it within their own experiences and perceptions to arrive at____(6) interpretation of the matter presented.

IV. Fill in the blanks with suitable prepositions.

CO3 L1

6 x ½ = 3M

I'm here ____ (1) express my views ____ (2) ragging. I believe ragging is a menace that is destroying the academic character ____ (3) many educational institutions. I consider ragging ____ (4) be an inhumane, unnatural and abusive form ____ (5) action which some senior students indulge ____ (6) so as to terrify 'fresher s', or newcomers, in educational institutions.

V. Fill in the blanks with correct verb form.

CO3 L3

5 x 1 =5M

1. My father _____ (go) to gym every day.
2. We _____ (buy) a new car tomorrow.
3. They _____ (live) in this town since 2008.
4. She _____ (see) an accident yesterday.
5. You _____ (go) to market now.

VI. Fill in the blanks with correct concord of the following sentences.

CO3 L1

6 x ½ = 3M

1. One lakh rupees _____ a lot of money.
2. Mathematics and English _____ my favourite subjects.
3. Most of the milk _____ gone.
4. Either Ram or Shyam _____ coming today.
5. Two-thirds majority _____ required for impeachment of the president.
6. Each boy and each girl _____ happy.

VII. Write the question tags for the following sentences.

CO3 L2

3 x 1 =3M

1. You haven't seen this film, _____?
2. She saw an accident, _____?
3. They made a kite, _____?

VIII. Fill in the blanks with suitable modal verbs.

CO3 L1

4 x ½ =2M

1. You _____ never too old to learn.
2. I _____ sorry for what I have done.
3. Our guests _____ arrived.
4. _____ they good friends of him?

IX. Write the correct spelling of the following words.

CO4 L3

4 x ½ =2M

1. dailoge
2. dictionory
3. parlament
4. acknowldage

X. Punctuate the following sentences.

CO4 L1

2 x 1= 2M

1. hari said I saw him today
2. what a lovely view you have hear ram said

XI. Rewrite the following sentences as directed. CO4 L2

5 x 1=5M

1. Shut the door. [change into passive voice]
2. The crew paved the entire stretch of highway [change into passive voice]
3. Rahul said, "I will have to reach home by 8.30." [change into indirect speech]
4. The boy said to the girl, "we are going on a holiday". [change into indirect speech]
5. The Pacific Ocean is deeper than the Arctic Ocean. [change into positive degree]

XII. Correct the following sentences. CO4 L2

2 x1 =2M

1. You must practice to speak English.
2. Unless you do not eat , you will not be strong.

XIII. Write a paragraph on ONE of the following. CO4 L2

1 x 5 = 5M

1. Your favourite hobby.
2. Impact of TV on both children and youth.

**A.G & S.G SIDDHARTHA DEGREE COLLEGE OF ARTS AND SCIENCE,
VUYYURU – 521165**
(An Autonomous College in the Jurisdiction of Krishna University, Machilipatnam.)
Accredited with “A” Grade by NAAC, Bengaluru

**Semester – III (CBCS)
ENGLISH PRAXIS COURSE-III**

A COURSE IN CONVERSATIONAL SKILLS

Course Code	ENG301	Course Delivery Method	Class Room/ Blended Mode - Both
Credits	03	CIA Marks	30
No.of Lecture Hours / Week	4	Semester End Exam Marks	70
Total No.of Lecture Hours	60	Total Marks	100
Year of Introduction:	Year of Offering: 2021-22	Year of Revision: -----	Percentage of Revision: 0%
CLASS:	II YEAR DEGREE (ALL COURSES)		

COURSE OBJECTIVE:

The objectives of the Syllabus are to enrich students’ reading, writing, and learning abilities so they can pursue their personal, academic and career goals through the acquisition and improvement of English Language skills. This course is designed in a manner suitable for the student to use personal and cultural knowledge to interpret the information presented in the text and 'create' meaning. The aim of this course is also to improve the speaking skills of the learners in regard to the sound- spelling relationship of the language appears anarchic.

COURSE OUTCOMES:

Being able to converse in a language in all situations is mastering it. Praxis III made efforts to help the students in helping this skill through speeches, autobiography and interviews of some world-famous personalities. The wonderful interviews chosen for Praxis-III, is a clear indication that at the end of the course, the student would be able to converse confidently, ask or answer in English language. The Units conclude with a series of exercises to hone language skills and will assist students in the curricular goal of self - learning.

- Students will become accomplished, active readers who appreciate ambiguity and complexity.
- Students will be able to write effectively for a variety of professional and social settings. They will practice writing as a process of motivated inquiry, engaging other writers’ ideas as they explore and develop their own.
- To enhance the confidence levels by acquiring knowledge of Role-plays, Debates and Descriptions.
- Enhancing basic skills to become a good communicator.
- To help students discover their latent leadership qualities and their social role of involvement.

Learning Outcomes

By the end of the course the learner will be able to :

- Speak fluently in English
- Participate confidently in any social interaction
- Face any professional discourse
- Demonstrate critical thinking
- Enhance conversational skills by observing the professional interviews

SYLLABUS

Unit	Learning Units	Lecture Hours
I	Speech 1. Tryst with Destiny - Jawaharlal Nehru Skills 2. Greetings 3. Introductions	10
II	Speech 1. Yes, We Can Barack Obama Interview 2. A Leader Should Know How to Manage Failure Dr.A.P.J.Abdul Kalam/India Knowledge at Wharton Skills 3. Requests	10
III	Interview 1. Nelson Mandela's Interview With Larry King Skills 2. Asking and Giving Information 3. Agreeing and Disagreeing	15
IV	Interview 1. JRD Tata's Interview With T.N.Ninan Skills 2. Dialogue Building 3. Giving Instructions/Directions	10
V	Speech 1. You've Got to Find What You Love Steve Jobs Skills 2. Debates 3. Descriptions 4. Role Play	15

REFERENCES:

1. ENGLISH PRAXIS III – A Course in Conversational Skills by S.B.Fatima Mary, VIVANTA PRESS -2021.
2. ENGLISH PRAXIS III – A Course in Conversational Skills by Himalaya Publishers – 2021.

Suggested Co-Curricular Activities

1. Elocution
2. Group discussion
3. Essay Writing
4. Creative Writing
5. Recitation
6. Debate

**A.G & S.G SIDDHARTHA DEGREE COLLEGE OF ARTS AND SCIENCE, VUYYURU -
521165**

(An Autonomous College in the Jurisdiction of Krishna University, Machilipatnam.)

Accredited at 'A' Grade by NAAC

ENGLISH	ENG 301C	2021-2022	B.A,B.Com & B.Sc
----------------	-----------------	------------------	-----------------------------

The Pattern of the Question Paper for Semester – III: ENG 301C

Section - A

I. Answer any FIVE of the following questions. **5x5=25M**
(Any Six essay questions should be given from all speeches and interviews in the given syllabus)

Section – B

II. Answer any FIVE of the following questions. **5x2=10M**
(Any Six short answer questions should be given from all speeches and interviews in the given syllabus)

Section – C

- III. GREETINGS** **1x4=4 Marks**
(This question should be given from the prescribed text book, page no's 08-17)
- IV. INTRODUCTIONS** **1x4=4 Marks**
(This question should be given from the prescribed text book, page no's 17-26).
- V. V. REQUESTS** **1x4=4 Marks**
(This question should be given from the prescribed text book, page no's 40-46)
- VI. ASKING AND GIVING INFORMATION** **1x4=4 Marks**
(This question should be given from the prescribed text book, page no's 58-63)
(OR)
- VII. AGREEING DISAGREEING**
(This question should be given from the prescribed text book, page no's 63-72)
- VIII. DIALOGUE BUILDING** **1x4=4 Marks**
(This question should be given from the prescribed text book, page no's 78-85)
- IX. GIVING INSTRUCTIONS / DIRECTIONS** **1x4=4 Marks**
(This question should be given from the prescribed text book, page no's 86-97)
- X. DEBATES** **1x4=4 Marks**
(This question should be given from the prescribed text book, page no's 105-112)
- XI. DESCRIPTIONS** **1x4=4 Marks**
(This question should be given from the prescribed text book, page no's 113-120)
- XII. ROLE-PLAY** **1x3=3 Marks**
(This questions should be given from the prescribed text book, page no's 121-124)

**A.G & S.G SIDDHARTHA DEGREE COLLEGE OF ARTS AND SCIENCE, VUYYURU -
521165**

(An Autonomous College in the Jurisdiction of Krishna University, Machilipatnam.)

Accredited at 'A' Grade by NAAC

ENGLISH	ENG 301C	2021-2022	B.A,B.Com & B.Sc
----------------	-----------------	------------------	-----------------------------

Time: 3 hours

Max Mark: 70

Question Paper Model

Section – A

I. Answer any FIVE of the following questions.

5x5=25M

1. What was the pledge that Jawaharlal Nehru wanted every citizen of India to take?
2. What does Barack Obama say about his victory in the American Presidential Election?
3. How did Steve Jobs keep himself going after getting fired from Apple?
4. What was the lesson about leadership that Abdul Kalam learnt from Prof.Satish Dhawan?
5. Why did Nelson Mandela say that prison was not a waste of time?
6. What are the major changes in Indian Business that were noticed by J.R.D.Tata?

Section – B

II. Answer any FIVE of the following questions.

5x2=10M

1. What was the ambition of the greatest man of our generation?
2. Why did Steve Jobs become interested in Calligraphy?
3. What was the achievement of freedom as a faithful movement for India?
4. How does Dr.A.P.J.Abdul Kalam describe his spirituality?
5. How does Tata describe Birla?
6. What does freedom and power bring according to Nelson Mandela?

Section – C

III. Mr.Krishna meets Ms.Bhaskar, his son's teacher, at the school. Write a dialogue between them.

1x4=4M

IV. Anvesh from Hifi Technologies, Hyderabad, goes to the office at Hyderabad to meet the Company's Finance Manager, on his prior appointment. Anvesh introduces himself to the Finance Manager's secretary, explaining who he is, where he is from and why he is there. Construct a dialogue between Anvesh and Secretary.

1x4= 4M

- V. List any five debate points on the Impact of Social Media on Youth. 1x4= 4M
- VI. Build up a conversation based on the hints given below. 1x4= 4M
Good morning – new to this place – in the Air Force – what do you do? – how fortunate! Need to enroll my daughter in a school – tell me about good schools in Visakhapatnam – thank you.
- VII. Rahul is a new student in the college. He asks Rajesh for directions to the library. Give some directions. 1x4= 4M
- VIII. Anu asks her friend Rajesh to get her college admission form from the college. Write a dialogue of request. 1x4= 4M
- IX. Construct a dialogue between the customer and a shop keeper seeking information about the price of the groceries. 1x4= 4M
- X. Your parents insist that you should cut down your extra-curricular activities in order to focus on your studies. Construct a dialogue either agreeing or disagreeing with your parent. 1x4= 4M
- XI. Plan a role play between a Principal and a parent asking him/her to take care of his/her child's attendance. 1x3= 3M

**Adusumilli Gopalakrishnaiah & Sugarcane Growers
Siddhartha Degree College of Arts & Science
(Autonomous)**

Vuyyuru-521 165, Krishna District, A.P.

--)00(--



Department of Telugu

Minutes of the meeting of Board of Studies

30.10.2021

తెలుగు విభాగం పాఠ్య నిర్ణాయక మండలి (బోర్డు ఆఫ్ స్టడీస్) సమావేశం - 12

తేది.30-10-2021 ఉదయం 10 గంటలకు అడుసుమిల్లి గోపాలకృష్ణయ్య చెఱకు రైతుల సీడ్లార్ల ద్వారా కళాశాల ఉయ్యూరు, తెలుగు శాఖలో 2021 - 2022 విద్యా సంవత్సరానికి తెలుగు శాఖ అధ్యక్షురాలు శ్రీమతి ఎమ్.ఎల్.యస్. కుమారి అధ్యక్షతన సమావేశం నిర్వహించడం జరిగినది.

తెలుగు పాఠ్యాంశ నిర్ణాయక మండలి సమావేశానికి చర్చనీయాంశాలు.

1. 2021-2022 విద్యా సంవత్సరంలో ప్రథమ,ద్వితీయ బి.ఎ., బి.కాం., బి.ఎస్.సి తరగతులకు మొదటి, మూడవ సెమిస్టర్లకు సంబంధించిన పాఠ్యాంశాల నిర్ణయం గురించి.
2. తెలుగు శాఖ అధ్యక్షుర్యంలో జర్నలిజం సర్టిఫికేట్ కోర్సు నిర్వహించడం గురించి.
3. అధ్యక్షురాలు అనుమతితో ఇతర అంశాలు ఏమైనా.....

తీర్మానాలు:

తేది.30-10-2021 ఉదయం 10 గంటలకు అడుసుమిల్లి గోపాలకృష్ణయ్య చెఱకు రైతుల సీడ్లార్ల ద్వారా కళాశాల ఉయ్యూరులో 2021 -2022 విద్యా సంవత్సరానికి రెండవ భాషగా తెలుగు పాఠ్యాంశాలు నిర్ణయించి తరువాత తెలుగు పాఠ్య నిర్ణాయక మండలి (బోర్డు ఆఫ్ స్టడీస్) సభ్యులు ఈ క్రింది తీర్మానాలను ఏకగ్రీవంగా ఆమోదించడమైనది.

1. 2021 -2022 విద్యా సంవత్సరం ప్రథమ బి.ఎ., బి.కాం., బి.ఎస్.సి తరగతులకి మొదటి సెమిస్టర్ సెలబ్షన్ లో ఉన్న 'పలనాటి బిబ్బులి' అనే పాఠాన్ని తీసివేసి దానికి బదులుగా 'మధుర స్నేహం' అనే పాఠాన్ని చేర్చాలని తీర్మానించడమైనది.
2. మూడవ సెమిస్టర్ ఆంధ్ర ప్రదేశ్ స్టేట్ కౌన్సిల్ ఆఫ్ హైయ్యర్ ఎడ్యుకేషన్ (APSCHE) వారు పెట్టిన సెలబ్షన్ ని యథాతథంగా కొనసాగించాలని తీర్మానించడమైనది.
3. 2021 -2022 విద్యా సంవత్సరం ప్రథమ బి.ఎ., బి.కాం., బి.ఎస్.సి ప్రశ్న పత్రం ఎక్స్ టర్నల్ 75 మార్కులకు, ఇంటర్నల్ 25 మార్కులకు ఇవ్వాలని, ద్వితీయ బి.ఎ., బి.కాం., బి.ఎస్.సి మూడవ సెమిస్టరుకు ప్రశ్న పత్రం ఎక్స్ టర్నల్ 70 మార్కులకు, ఇంటర్నల్ 30 మార్కులకు ఇవ్వాలని తీర్మానించడమైనది.
4. 2021 -2022 విద్యా సంవత్సరం ప్రథమ, ద్వితీయ బి.ఎ.,బి.కాం., బి.ఎస్.సి విద్యార్థులకు కనీస పాస్ మార్కులు లేవని తీర్మానించడమైనది.
5. తెలుగు శాఖ అధ్యక్షుర్యంలో జర్నలిజం సర్టిఫికేట్ కోర్సు నిర్వహించాలని తీర్మానించడమైనది.

హాజరైన సభ్యులు:-

1. శ్రీమతి ఎమ్.ఎల్.యస్ కుమారి M.L.S. Kumari
తెలుగు శాఖ అధ్యక్షురాలు, పాఠ్య నిర్ణాయక మండలి అధ్యక్షులు.

2. శ్రీమతి ఎమ్. రమాదేవి M. Rama Devi
తెలుగు అధ్యాపకురాలు

3. శ్రీమతి బి.ఎస్.ఎల్ పద్మశ్రీ B.S.L. Padma Sri
తెలుగు శాఖ అధ్యక్షురాలు,
ఎస్.పి మహిళా కళాశాల,
మచిలీపట్నం.
(కృష్ణా విశ్వవిద్యాలయం నామిని)

4. డా॥ వై. పూర్ణచంద్ర రావు
తెలుగు శాఖ అధ్యక్షులు
అ.ప్రో,
పి.బి సిద్ధార్థ కళాశాల,
విజయవాడ - 10
విషయ నిపుణులు (Subject Expert)

6. డా॥ జి. శ్రీనివాస్, G. Sri - n
తెలుగు శాఖ అధ్యక్షులు,
ప్రభుత్వ డిగ్రీ కళాశాల,
చింతలపూడి.
విషయ నిపుణులు (Subject Expert)

7. కుమారి పి. కాశీ విశ్వేశ్వరి P. Kasi Vishweswari
విద్యార్థి ప్రతినిధి.





A.G & S.G.SIDDHARTHA DEGREE COLLEGE OF ARTS & SCIENCE

Vuyyuru-521165.

NAAC recredited at 'A' level
Autonomous -ISO 9001 – 2015 Certified

Department of Telugu

Title of the Paper: Telugu

Semester: I I B.A, B.Com,B.Sc.

Course Code	TELTIIA	Course Delivery Method	Class Room / Blended Mode - Both
Credits	4	CIA Marks	25
No. of Lecture Hours / Week	4	Semester End Exam Marks	75
Total Number of Lecture Hours	60	Total Marks	100
Year of Introduction :2020-21	Year of Offering: 2021 - 22	Year of Revision: --- 2021-22	Percentage of Revision: 10%

కోర్స్ అవుట్ కమ్స్:

ఈ కోర్సు విజయవంతంగా ముగించాక, విద్యార్థులు క్రింది అభ్యసన ఫలితాలను పొందగలరు.

1. ప్రాచీన తెలుగు సాహిత్యం యొక్క ప్రాచీనతను, విశిష్టతను గుర్తిస్తారు. తెలుగు సాహిత్యంలో ఆదికవి స్వరూప కాలనాటి భాషా సంస్కృతులను, ఇతిహాసకాలం నాటి రాజనీతి విషయాలపట్ల పరిజ్ఞానాన్ని పొందగలరు.
2. శివకవుల కాలనాటి మత పరిస్థితులను, భాషా విశేషాలను గ్రహిస్తారు. తెలుగు నుడికారం, సామెతలు, లోకోత్కలు, మొదలైన భాషాంశాల పట్ల పరిజ్ఞానాన్ని పొందగలరు.
3. తిక్కన భారతనాటి మత, ధార్మిక పరిస్థితులను, తిక్కన కవితా శిల్పాన్ని, నాటకీయతను అవగాహన చేసుకోగలరు.
4. పోతన అద్భుత కథాకథన శిల్పం, సజీవపాత్ర చిత్రణ, శబ్దాలంకారాల ప్రయోగం మొదలగు విభిన్న రీతుల పట్ల అభిరుచిని పొందగలరు. మొల్ల కవిత్వంలోని వీనుల విందైన పదాలు, పాత్రల మనోభావాల చిత్రణ గుర్తించగలరు.
5. తెలుగు పద్యం స్వరూప-స్వభావాలను, సాహిత్యాభిరుచిని పెంపొందించుకుంటారు. ప్రాచీన కావ్యభాషలోని వ్యాకరణాంశాలను అధ్యయనం చేయడం ద్వారా భాషా సామర్థ్యాన్ని, రచనలో మెలకువలను గ్రహించగలరు.

లెర్నింగ్ ఆబ్జెక్టివ్స్:

1. తెలుగు భాషాసాహిత్యాల పట్ల ప్రీతి, మమకార, ప్రాచీన కాలంలోని రాజనీతి పట్ల అవగాహన కల్గుతుంది.
2. ప్రాచీన కాలం నాటి చరిత్ర, సంస్కృతి ఆచార సంప్రదాయాల పట్ల ఆసక్తి కల్గుతుంది.
3. అలనాటి ధర్మ, మత పరిస్థితులు, నైతిక విలువల పట్ల అవగాహన ఏర్పడుతుంది.
4. పూర్వ కవుల సజీవ పాత్రల సృష్టి, వివిధ శబ్ద ప్రయోగాల పట్ల అభిరుచి కల్గుతుంది.
5. కావ్య భాషలోని భాషా పరిజ్ఞానం, వ్యాకరణాంశాలు, వివిధ రచనలలోని మెలకువలను తెలుసుకుంటారు.

TELUGU

TELEHA

2020-'21

I B.A., I B.Com., IB.Sc.

TELUGU-I

యూనిట్ - I

రాజనీతి - సస్వయ

మహాభారతము - సభాపర్వం - ప్రథమాశ్వాసంలో 26వ పద్యము "వీపంశమున.... నీవు వారిదైన నేర్పెటింగి" నుండి 57వ పద్యము "నాయథాశక్తి వాని ససుష్టుతు ఖ్రియముతోడ" వరకు.

యూనిట్ - II

దక్షయజ్ఞం - సన్నెచోడుడు

కుమార సంభవం - ద్వితీయాశ్వాసంలో 49వ పద్యం "అంతకమున్ను... భయంకరా కారంబుదాల్చిన" నుండి 86వ పద్యం "ప్రపథగణము.... కనిరిశంభ" వరకు.

యూనిట్ - III

ధౌమ్యధర్మోపదేశము - తిక్కన

మహాభారతము - విరాటపర్వము - ప్రథమాశ్వాసంలో 116వ పద్యం "ఎఱిగెడు వారికినైనను.... వలయు దగియెడు బుద్ధుల్" నుండి 146వ పద్యం "అతడు నియతితోడ సంచయములు దగ జపించుచుండె" వరకు.

యూనిట్ - IV

మధుర స్నేహం - షోతన

ఆంధ్రమహాభాగవతము - దశమస్కంధము - కుచోలోపాఖ్యానంలో 962వ పద్యం "లలిత పతివ్రతాతిలకంబు... కుపాయముహింప వైతి" నుండి 983వ పద్యం "తన ప్పుదుతల్పమందు... ధరణీసురు దెంతటి భాగ్యవంతుడో" వరకు.

యూనిట్ - V

సీతారావణ సంవాదం - మొల్ల

రామాయణము - సుందరకాండములో 40వ పద్యం "ఆరామంజూచి.... వృక్షం బారోహించి యందు" నుండి 87వ పద్యం "కాపున నిక్కోపమలియెడ.... మనకు దిక్కగు మీదన్" వరకు.

వ్యాకరణము:

1. సంధులు:- సపర్క, గుణ, యణాదేశ, వృద్ధి, అకార, ఇకార, ఉకార, త్రిక సంధులు.
2. సమాసములు:- తత్పరుష, కర్మధారయ, ద్వంద్వ, ద్విగు, బహువ్రీహి సమాసములు.
3. ఛందస్సు:- పృత్య పద్యాలలో ఉత్పలమాల, చ్చంపకమాల, శార్వలము, మత్తేభము.
జాతులు, ఉపజాతుల్లో కందము, తేటగీతి, ఆటవెలది మరియు ముత్తాలసరాలు.
4. అలంకారములు:- శబ్దాలంకారాల్లో అనుప్రాసాలైన వృత్త్యనుప్రాస, ఛేకానుప్రాస, లాటానుప్రాస, అంత్యానుప్రాసములు. అర్థాలంకారాల్లో ఉపమ, ఉత్పేక్ష, రూపక, శ్లేషలు.

ఆధార గ్రంథాలు:

1. శ్రీమదాంధ్ర మహాభారతము - సభాపర్వము - తిరుమల తిరుపతి దేవస్థానం ప్రచురణ
2. శ్రీమదాంధ్ర మహాభారతము - విరాటపర్వము - తిరుమల తిరుపతి దేవస్థానం ప్రచురణ
3. కుమార సంభవం - సన్నెచోడుడు
4. శ్రీ మహాభాగవతము - షోతన
5. రామాయణము - మొల్ల

TELUGU	TELHIA	2020-'21	B.A., B.Com., B.Sc.
--------	--------	----------	---------------------

ప్రశ్నపత్ర నిర్మాణ సూచిక:

TELUGU-I

1. ప్రతిపదార్థ పద్యాలు :	2-1	1×7=7మా,	2. సందర్భ సహిత వ్యాఖ్యలు:	5-3	3×4=12మా
3. సంగ్రహరూప ప్రశ్నలు :	5-3	3×4=12మా,	4. వ్యాసరూప ప్రశ్నలు :	5-3	3×8=24మా
5. సంధులు :	5-3	3×2=6మా,	6. సమాసములు :	5-3	3×2=6మా
7. ఛందస్సు :	2-1	1×4=4మా,	8. అలంకారములు :	2-1	1×4=4మా
				మొత్తం =	75మా

గమనికలు / నూచనలు:

1. ప్రతిపదార్థ పద్యాలు:- "రాజనీతి, ధౌమ్యధర్మోపదేశం, మధురస్నేహం" అనే మూడు పాఠాల నుండి రెండు పద్యాలు ఇవ్వాలి. అవి కూడ ఈ క్రింది పద్యాల్లో నుండి రెండు ఇవ్వాలి-

రాజనీతి:

1. ఉత్తమ మధ్యమాధమ కాలము దప్పకుండగన్
2. బహుధనధాన్య సంగ్రహము భవత్పురి రక్ష్యములైన దుర్గముల్

ధౌమ్యధర్మోపదేశము:

3. రాజ గృహంబు కంటె దగదట్టు సేయగన్
4. ధరణిపు చక్క నుండుటనీతి కొల్వనన్

మధురస్నేహం:

5. కలలో నందసు సంపద్విశేషోన్నతుల్.
6. కనిదాయం జనునంత విలోలుండై దిగెన్ దల్పమున్.

2. సందర్భసహిత వ్యాఖ్యలు:- "రాజనీతి, దక్షయజ్ఞం, ధౌమ్యధర్మోపదేశము, మధురస్నేహం, సీతారావణ సంవాదం" అనే ఐదు పాఠాలనుండి ఒక్కొక్కటి చొప్పున ఒక్కో పాఠం నుండి ఒక సందర్భసహిత వ్యాఖ్య ఇవ్వాలి.

3. సంగ్రహరూప ప్రశ్నలు:- "రాజనీతి, దక్షయజ్ఞం, ధౌమ్యధర్మోపదేశము, మధురస్నేహం, సీతారావణసంవాదం" అనే ఐదు పాఠాల నుండి ఒక్కొక్కటి చొప్పున ఒక్కో పాఠం నుండి సంగ్రహరూప ప్రశ్న ఇవ్వాలి.

4. వ్యాసరూప ప్రశ్నలు:- "రాజనీతి, దక్షయజ్ఞం, ధౌమ్యధర్మోపదేశము, మధురస్నేహం, సీతారావణసంవాదం" అనే ఐదు పాఠాల నుండి ఒక్కొక్కటి చొప్పున ఒక్కో పాఠం నుండి వ్యాసరూప ప్రశ్న ఇవ్వాలి.

5. సంధులు:- "సవర్ణ, గుణ, యణాదేశ, వృద్ధి, అకార, ఇకార, ఉకార, త్రిక సంధు"ల నుండి ఐదు సంధులు ఇవ్వాలి.

6. సమాసములు:- "తత్పురుష, కర్మధారయ, ద్వుంద్య, ద్విగు, బహుప్రీహి సమాసముల" నుండి ఐదు సమాసములు ఇవ్వాలి.

7. ఛందస్సు:- వృత్తపద్యాలైన "ఉత్పలమాల, చంపకమాల, శార్దూలము, మత్తేభము"ల నుండి ఒక పద్యపాదమును ఇవ్వాలి.

జాతులు, ఉపజాతుల పద్యాలైన "కందము, తేటగీతి, ఆటవెలది" మరియు 'ముత్యాలసరాలు' నుండి ఏదైన మూడిచ్చి ఒకదానిని లక్ష్యలక్షణ సమన్వయం చేయమనాలి.

8. అలంకారములు:- అర్థాలంకారాలైన "ఉపమ, ఉత్ప్రేక్ష, రూపకము, శ్లేష"ల నుండి ఒక అలంకారము ఇవ్వాలి. అది కూడ ఐదు పాఠాల (రాజనీతి, దక్షయజ్ఞం, ధౌమ్యధర్మోపదేశము, మధురస్నేహం, సీతారావణసంవాదం) నుండి ఒక పద్యాన్ని ఇవ్వాలి- శబ్దాలంకారాల నుండి "వృత్తనుప్రాస, ఛేకానుప్రాస, లాటానుప్రాస, అంత్యానుప్రాస"ల నుండి రెండు అలంకారములు ఇచ్చి, ఒక అలంకారము వ్రాయమనాలి.

ఇక సమూహ ప్రశ్నపత్రాన్ని పరిశీలించి తరువాత ప్రశ్నపత్రాన్ని తయారు చేసుకోవాలి.

సమూహ ప్రశ్నపత్రం

Course Code: TEL T11A (Telugu-I)

Max. Marks: 75M

Time: 3 Hrs.

Pass Min. : 30M

I. క్రింది వానిలో ఒకదానికి ప్రతి పదార్థ తాత్పర్యమును వ్రాయండి: 7మా

1. బహుధనధాన్య సంగ్రహము బాణశరాసన యోధవీర సం
గ్రహము నిరంతరాంతరుదకంబులు ఘోసరసేందనౌఘ సం
గ్రహము ననేక యంత్రములు గల్గియ సాధ్యములై ద్విషద్యయా
వహు లగుచుండ నొప్పునె భవత్పరి రక్ష్యములైన దుర్గముల్.
లేదా
2. కలలోనందను మున్నెఱుంగని మహా కష్టాత్తుడై నట్టి దు
ర్బలు దౌపత్నమయంబునన్ నిజ పదాబ్జాతంబులు ల్లంబులోన్
దలపన్నంతనె మెచ్చి యార్తి హరుడై తన్నైన నిచ్చున్ సు ని
శ్చల భక్తిన్ భజియించువారి కిడడే సంపద్విశేషోన్నతుల్.

II. క్రింది వానిలో మూడింటికి సందర్భసహిత వ్యాఖ్యలు వ్రాయండి: 3 x 4 = 12మా

1. వార్త నిర్వహింపవలయు బతికి.
2. నన్ను బనుపు దక్షు బట్టి తెచ్చెదన్.
3. పురుషార్థంబునకు హాని పుట్టక యున్నే?
4. గోవింద దర్శనోత్సాహి యగుచు.
5. ఉండు టిది న్యాయమె లతాంగీ !

III. క్రింది వానిలో మూడింటికి సంగ్రహరూప సమాధానాలు వ్రాయండి: 3 x 4 = 12మా

1. రాజు చేయకూడని పనుల్ని తెల్పండి?
2. ప్రమథులు దక్షుని బంధించిన తీరును తెల్పండి?
3. ధౌమ్యుని ఉపదేశానంతరం ఏమి జరిగింది?
4. అంతఃపురకాంతలు కుచేలుని గూర్చి భావించిన విషయాల్ని తెల్పండి?
5. త్రిజట తన స్వప్నాన్ని ఏమని వివరించెను?

IV. క్రింది వానిలో మూడింటికి వ్యాసరూప సమాధానాలు వ్రాయండి: 3 x 8 = 24మా

1. ప్రజాపాలనలో రాజులు పాటించాల్సిన ధర్మాశేషి?
2. 'దక్షయజ్ఞం' సారాంశాన్ని వ్రాయండి.
3. ధౌమ్యుడు పాండవులకు చేసిన ధర్మోపదేశాన్ని వివరించండి.
4. 'మధురస్నేహం' పాఠ్య సారాంశాన్ని తెల్పండి?
5. సీతారావణ సంవాదాన్ని వివరించండి.

V. క్రింది వానిలో మూడింటిని విడదీసి, సంధి కార్యము వ్రాయండి: $3 \times 2 = 6$ మా

1. శత్రైకవృద్ధి
2. జగమెల్ల
3. మనుజేంద్రుడు
4. కష్టాత్ముడు
5. ఇక్కోమలి

VI. క్రింది వానిలో మూడింటికి విగ్రహ వాక్యాలు వ్రాసి, సమాస నామములు తెల్పండి: $3 \times 2 = 6$ మా

1. అష్టాంగాలు
2. అశ్రమము
3. భీమార్జునులు
4. మధురస్నేహం
5. తోయజాక్షి

VII. క్రింది పద్య పాదాన్ని గణ విభజన చేసి, యతిని గుర్తించి, ఏ పద్యపాదమో తెల్పండి: $1 \times 4 = 4$ మా

తన మృదుతల్పమందు వనితామణియైన రమాలలామ పొం

లేదా

క్రింది వానిలో ఒకదానిని లక్ష్య లక్షణ సమన్వయం చేయండి.

1. తేటగీతి
2. ముత్యాలసరాలు
3. ఆటవెలది

VIII. క్రింది పద్యంలోని అలంకారమును గుర్తించి, లక్ష్య లక్షణ సమన్వయం చేయండి: $1 \times 4 = 4$ మా

బాల సఖుడైన యప్పద్య పత్రనేత్రు

గాన నేగి దరిద్రాంధకార మగ్ను

లయిన మము నుద్ధరింపుము హరి కృపాక

టాక్ష రవిదీప్తి వడసి మహాత్మ! నీవు.

లేదా

క్రింది వానిలో ఒకదానిని లక్ష్య లక్షణ సమన్వయం చేయండి.

1. వృత్తాను ప్రాసము
2. లాటానుప్రాసము



**A.G & S.G.SIDDHARTHA DEGREE COLLEGE OF
ARTS & SCIENCE**

Vuyyuru-521165.

NAAC recredited at 'A' level
Autonomous -ISO 9001 – 2015 Certified

Department of Telugu

Title of the Paper: General Telugu

Semester: III I I B.A, B.Com,, B.Sc.

Course Code	TEL301	Course Delivery Method	Class Room / Blended Mode - Both
Credits	4	CIA Marks	30
No. of Lecture Hours / Week	4	Semester End Exam Marks	70
Total Number of Lecture Hours	60	Total Marks	100
Year of Introduction :2020-21	Year of Offering: 2021 - 22	Year of Revision: --- 2021-22	Percentage of Revision: 0%

యూనిట్ సంఖ్య: 5**కోర్స్ అవుట్ కమ్స్:**

ఈ కోర్సు విజయవంతంగా ముగించాక, విద్యార్థులు క్రింది అభ్యసన ఫలితాలను పొందగలరు.

1. తెలుగు సాహిత్య అభ్యసనం ద్వారా నేర్చుకున్న నైపుణ్యాలను, సృజనాత్మక నైపుణ్యాలుగా మార్చుకోగలరు.
2. విద్యార్థులు భాషాతత్వాన్ని, అవశ్యకతను, ప్రాధాన్యాన్ని గుర్తిస్తారు.
3. భాషా నైపుణ్యాలను అలవర్చుకోవడం, వినియోగించడం నేర్చుకుంటారు.
4. ప్రాచీన పద్య రచనతోపాటు ఆధునిక కవిత, కథ, వ్యాసం మొదలైన సాహిత్య ప్రక్రియల పట్ల అవగాహన పొందుతారు.
5. సృజన రంగం, ప్రసార మాధ్యమాలు, అనువాద రంగాల పట్ల విద్యార్థులకు అవగాహన కలుగుతుంది.

లెర్నింగ్ అబ్జెక్టివ్స్:

1. సృజనాత్మక నైపుణ్యాల పట్ల విద్యార్థులకు ఆసక్తి కలుగుతుంది.
2. మనిషి వ్యక్తిగత జీవనానికి, సామాజిక వ్యవస్థ పటిష్ఠతకు భాష ప్రధానమని, భాషలోని కీలకాంశాలు వర్ణం, పదం, వాక్యాల ప్రాధాన్యాన్ని గుర్తించడంతోపాటు వాగ్రూప, లిఖితరూప వ్యక్తీకరణలో భాషా నైపుణ్యాలను మెరుగుపర్చుకుంటారు.
3. రచనా శైలి, భాషణా నైపుణ్యాలను సృజనాత్మక రూపంలో వ్యక్తీకరించడం తెలుసుకుంటారు.
4. పద్య రచనతోపాటు, ఆధునిక కవిత, కథ, వ్యాసం మున్నగు సాహిత్య ప్రక్రియల నిర్మాణాలకు సంబంధించిన సిద్ధాంత విషయాల్ని, రచనా నైపుణ్యాల్ని తెలుసుకోవడం జరుగుతుంది.
5. సృజన, ప్రసారమాధ్యమ, అనువాద రంగాల్లో నైపుణ్యం పొందడంతోపాటు ఉపాధి అవకాశాల్ని పొందుతారు.

యూనిట్-I

వ్యక్తీకరణ నైపుణ్యాలు

1. భాష-ప్రాథమికాంశాలు: - భాష-నిర్వచనం, లక్షణాలు, ఆవశ్యకత, ప్రయోజనాలు.
2. 'వర్ణం-పదం-వాక్యం', వాక్య లక్షణాలు, సామాన్య-సంయుక్త-సంశ్లిష్ట వాక్యాలు.
3. భాషా నిర్మాణంలో 'వర్ణం-పదం-వాక్యం' ప్రాధాన్యత.

యూనిట్-II

సృజనాత్మక రచన

4. కవితా రచన:- ఉత్తమ కవిత - లక్షణాలు.
5. కథా రచన:- ఉత్తమ కథ - లక్షణాలు.
6. వ్యాస రచన:- ఉత్తమ వ్యాసం - లక్షణాలు.

యూనిట్-III

అనువాద రచన

7. అనువాదం:- నిర్వచనం, అనువాద పద్ధతులు.
8. అనువాద సమస్యలు:- భౌగోళిక, భాషా, సాంస్కృతిక సమస్యలు, పరిష్కారాలు.
9. అభ్యాసము:- ఆంగ్లం నుండి తెలుగునకు ఒక పేరాను అనువదించడం.

యూనిట్-IV

మాధ్యమాలకు రచన-I:- ముద్రణ / ప్రింట్ మీడియా

10. ముద్రణా మాధ్యమం / అచ్చు :- పరిచయం, పరిధి, వికాసం.
11. వివిధ రకాల పత్రికలు - పరిశీలన, పత్రికా భాష, శైలి, వైవిధ్యం.
12. పత్రికా రచన:- వార్తా రచన, సంపాదకీయాలు, సమీక్షలు - ఆవగాహన.

యూనిట్-V

మాధ్యమాలకు రచన-II:- ప్రసార మాధ్యమం / ఎలక్ట్రానిక్ మీడియా

13. ప్రసార మాధ్యమాలు:- నిర్వచనం, రకాలు, విస్తృతి, ప్రయోజనాలు.
14. శ్రవణ మాధ్యమాలు-రచన:- రేడియో రచన, ప్రసంగాలు, నాటికలు, ప్రసార సమాచారం.
15. దృశ్య మాధ్యమాలు-రచన:- వ్యాఖ్యానం / యాంకరింగ్, టెలివిజన్ రచన.

ఆధార గ్రంథాలు / వ్యాసాలు:

1. వ్యక్తీకరణ నైపుణ్యాలు-చూ.
 1. ఆధునిక భాషా శాస్త్ర సిద్ధాంతాలు - ఆచార్య పి.ఎస్. సుబ్రహ్మణ్యం.
 2. తెలుగు భాషా చరిత్ర - సం.ఆచార్య భద్రరాజు కృష్ణమూర్తి.
 3. తెలుగు వాక్యం - డా.చేకూరి రామారావు.
2. ఉత్తమ కవిత-లక్షణాలు - చూ.
 1. నవ్య కవిత్వ లక్షణములు - ఆచార్య సి.నారాయణరెడ్డి.
 2. ఆధునికాంధ్ర కవిత్వము - సంప్రదాయములు, ప్రయోగములు: చతుర్థ ప్రకరణము.
3. ఉత్తమ కథ - లక్షణాలు - చూ.
 1. కథా శిల్పం - వల్లంపాటి వెంకట సుబ్బయ్య, పుటలు:11-17
4. ఉత్తమ వ్యాసం - లక్షణాలు - చూ.
 1. చదువు-సంస్కృతి (వ్యాసం) - కొడవటిగంటి కుటుంబరావు.
5. అనువాద రచన - చూ.
 1. అనువాద సమస్యలు - రాచమల్లు రామచంద్రారెడ్డి, పుటలు: 61-75, 85-94
 2. అనువాద పద్ధతులు ఆచరణ సమస్యలు - చేకూరి రామారావు
 3. 'భాషాంతరంగం', పుటలు: 130-146, తెలుగు విశ్వవిద్యాలయం ప్రచురణ.
6. ముద్రణా మాధ్యమం-చూ.
 1. మాధ్యమాలకు రచన, పుటలు: 9-12, డా.బి.ఆర్. అంబేద్కర్ విశ్వవిద్యాలయ ప్రచురణ.
7. పత్రికా భాష-చూ.
 1. మాధ్యమాలకు రచన, పుటలు: 67-74, డా.బి.ఆర్. అంబేద్కర్ విశ్వవిద్యాలయ ప్రచురణ.
8. పత్రికా రచన- చూ.
 1. తెలుగు-మౌలికాంశాలు, పుటలు: 59-69, డా.బి.ఆర్. అంబేద్కర్ విశ్వవిద్యాలయ ప్రచురణ.
9. ప్రసార మాధ్యమాలు- చూ.
 1. మాధ్యమాలకు రచన, పుటలు: 3-10, డా.బి.ఆర్. అంబేద్కర్ విశ్వవిద్యాలయ ప్రచురణ.
10. రేడియో రచన- చూ.
 1. మాధ్యమాలకు రచన, పుటలు: 141-148, డా.బి.ఆర్. అంబేద్కర్ విశ్వవిద్యాలయ ప్రచురణ.
11. వ్యాఖ్యానం/యాంకరింగ్ - చూ.
 1. మాధ్యమాలకు రచన, పుటలు: 178-181, డా.బి.ఆర్. అంబేద్కర్ విశ్వవిద్యాలయ ప్రచురణ.
12. టెలివిజన్ రచన- చూ.
 1. మాధ్యమాలకు రచన, పుటలు:153-160, డా.బి.ఆర్. అంబేద్కర్ విశ్వవిద్యాలయం ప్రచురణ.
13. తెలుగు జర్నలిజం- డా. బూదరాజు రాధాకృష్ణ

మాదిరి ప్రశ్నాపత్రం

పార్ట్ - ఎ

క్రింది వానిలో ఐదంటికి సంక్షిప్త సమాధానాలు రాయండి.

5 X 4 = 20మా

1. బాష - ప్రయోజనాలు
2. వాక్యం-లక్షణాలు
3. టెలివిజన్ రచన
4. రేడియో రచన
5. ఉత్తమ వ్యాసం-లక్షణాలు
6. సంశ్లేష్ట వాక్యం
7. సంపాదకీయాలు
8. మాండలికాలు
9. వార్తా రచన
10. క్రింది అంశాన్ని తెలుగులోకి అనువదించి రాయండి.

To many, Indian thought, Indian manners, Indian customs, Indian philosophy, Indian Literature are repulsive at the first site; but let them preserve, let them read, let them become familiar with the great principles underlying these ideas, and it is ninety - nine to one that the charm will come over them, and fascination will be the result. Slow and silent, as the gentle dew that falls in the morning, un seen and unheard yet producing, a most tremendous result, has been the work of the calm, patient, all suffering spiritual race up on the old of thought.

పార్ట్ - బి

క్రింది వానిలో ఐదు ప్రశ్నలకు వ్యాసరూప సమాధానాలు రాయండి.

5 X 10 = 50మా

11. బాషా నిర్మాణంలో వర్ణం, పదం, వాక్యాల ప్రాధాన్యతను వివరించండి.
12. భాషను నిర్వచించి, లక్షణాలు రాసి, ప్రామాణిక భాషను పరిచయం చేయండి.
13. ఉత్తమ కవితా లక్షణాలను విశ్లేషించండి.
14. ఉత్తమ కదా లక్షణాలను వివరించండి.
15. అనువాద సమస్యలను, వాటి పరిష్కారాలను గూర్చి రాయండి.
16. అనువాద లక్షణాలను వివరిస్తూ అనువాద పద్ధతులను గూర్చి రాయండి.
17. ముద్రణా మాధ్యమాన్ని పరిచయం చేస్తూ దాని పరిధి, వికాసాలను వివరించండి.
18. పత్రికా రచనను గురించి విశ్లేషణాత్మక వ్యాసం రాయండి.
19. ప్రసార మాధ్యమాల విస్తృతి, ప్రయోజనాలను సమీక్షించండి.
20. యాంకరింగ్ నిర్వహణ తీరు తెన్నులను వివరించండి.

A.G & S.G. Siddhartha Degree College Of Arts & Science
Vuyyuru – 521 165, Krishna Dist.
(An Autonomous College in the jurisdiction of Krishna University, Machilipatnam, A.P.,
ACCREDITED AT 'A' NACC
I Year B.A., B.Com., B.SC.,
Telugu III SEMESTER
Guidelines to paper Setters

పార్ట్ - ఎ

1వ ప్రశ్నలో సంక్షిప్త సమాధానాలు :

యూనిట్ - 1 నుండి రెండు ప్రశ్నలు
యూనిట్ - 2 నుండి రెండు ప్రశ్నలు
యూనిట్ - 3 నుండి రెండు ప్రశ్నలు
యూనిట్ - 4 నుండి రెండు ప్రశ్నలు
యూనిట్ - 5 నుండి రెండు ప్రశ్నలు
మొత్తం 10 ప్రశ్నలు ఇవ్వవలెను.

పార్ట్ - బి

2వ ప్రశ్నలో పెద్ద సమాధానాలు :

యూనిట్ - 1 నుండి రెండు ప్రశ్నలు
యూనిట్ - 2 నుండి రెండు ప్రశ్నలు
యూనిట్ - 3 నుండి రెండు ప్రశ్నలు
యూనిట్ - 4 నుండి రెండు ప్రశ్నలు
యూనిట్ - 5 నుండి రెండు ప్రశ్నలు
మొత్తం 10 ప్రశ్నలు ఇవ్వవలెను.

**Adusumilli Gopalakrishnaiah & Sugarcane Growers
Siddhartha Degree College of Arts & Science
(Autonomous)**

Vuyyuru-521 165, Krishna District, A.P.

--)00(--



Department of Hindi

Minutes of the meeting of Board of Studies

29.10.2021

Minutes of the meeting of Board of Studies in Hindi for the Autonomous Courses of A.G. & S.G Siddhartha Degree College of Arts & Science, Vuyyuru at 11.00AM on 29-10-2021 in the Department of Hindi through online.

Members Present:

- | | | |
|---------------------------------|------------------------------|--|
| 1.
Sk.Anwar | Chairman | Head of the Department of Hindi
AG & SGS Degree College of
Arts & Science, Vuyyuru. |
| 2.
Dr.V. Mohana Rao | University
Representative | Principal
KRK Govt. Degree College
Singarakondapalem, Addanki-523201,
Prakasam District. |
| 3.
Dr.Kakani Srikrishna | Academic Council
Nominee | Assistant Professor
Department of Hindi
Acharya Nagarjuna University,
Nagarjuna Nagar-522510. |
| 4.
Smt.A.Ramalakshmi | Academic Council
Nominee | Assistant Professor
Department of Hindi
Sri Durga Malleswara Siddhartha
Mahila Kalasala, Vijayawada-10. |
| 5.
Dilshad Begum | Student's
Representative | Lecturer in Chemistry
AG & SGS Degree College of
Arts & Science, Vuyyuru. |

Agenda for BOS Meeting

- 1.To discuss about the Syllabus, Model Question Papers and guidelines of I & III semesters of I & II degree in Hindi for the Academic year 2021-2022.
- 2.To discuss about the change of Question Papers of I & III semesters for the academic year 2021-2022.
- 3.To discuss about the I & III semester syllabus for the Academic year 2021-2022.

4.Any other matter.

Resolutions

- 1.It is unanimously resolved that there is no change in the syllabi of I & III semesters of I & II degree in Hindi for the Academic year 2021-2022.
- 2.It is unanimously resolved that there is no change in the model question papers of I & III semesters of I & II degree in Hindi for the Academic year 2021-2022.
- 3.It is unanimously resolved that there is no change in the syllabus and the model question paper of III semester for the academic year 2021-2022.
- 4.It is unanimously resolved to follow the evaluation ratio 70:30(External and Internal) for the III semester and evaluation ratio 75:25 for the I semester.



**A.G & S.G.SIDDHARTHA DEGREE COLLEGE OF
ARTS & SCIENCE**

Vuyyuru-521165.

NAAC reaccredited at 'A' level

Autonomous -ISO 9001 – 2015 Certified

Title of the Paper: GENERAL HINDI

Semester: I

Course Code	HINT11A	Course Delivery Method	Class Room / Blended Mode - Both
Credits	4	CIA Marks	25
No. of Lecture Hours / Week	4	Semester End Exam Marks	75
Total Number of Lecture Hours	60	Total Marks	100
Year of Introduction :2020-21	Year of Offering: 2021 - 22	Year of Revision: --- 2021-22	Percentage of Revision:10%

HINDI	HINT11A	2021-'22	B.A., B.Com. & B.Sc.
-------	---------	----------	----------------------

SEMESTER-I

Credits – 4

HINDI - I

COURSE OUTCOMES:

- CO1 - मानव मूल्यों को पहचानकर समाज कल्याण हेतु देने के लिए तैयार रहना ।
CO2 - आधुनिक युग की भावनाओं को पहचानकर सामाजिक समस्याओं का सामना करते हुए, निरंतर आगे बढ़ना ।
CO3 - विद्यार्थियों को शब्दावली से एक भाषा से दुसरे भाषा का अन्ववाद कर सकता है ।
CO4 - छात्रों को इस व्याकरण के द्वारा भाषा में निपुणता आती हैं ।
CO5 - छात्रों के इस पत्र-लेखन द्वारा लिखित कार्य बढ़ता है और संप्रेषण का विकास होता है ।

I. गद्य संदेश :

1. साहित्य की महत्ता
2. सच्ची वीरता
3. मित्रता

II. कथा - लेक :

1. मुक्तिधन
2. गूदड साई
3. उसने कहा था

III. व्याकरण : कार्यालयीन हिन्दी शब्दावली

(हिन्दी से अंग्रेजी में बदलना तथा अंग्रेजी से हिन्दी में बदलना)

IV. व्याकरण : लिंग, वचन, उल्टे शब्द, काल, वाच्य, वाक्य शुद्ध कीजिए

V. पत्र-लेखन : पत्र-लेखन (मित्र को पत्र, पिताजी को पत्र)

Recommended Books:

1. गद्य संदेश - Dr. V.L.Narasimham Siva Koti
2. कथा लेक - Dr. Ghana Shyam

A.G. & S.G. SIDDHARTHA SCIENCE & ARTS DEGREE COLLEGE, VUYYURU.
An Autonomous College in the jurisdiction of Krishna University, Machilipatnam.

HINDI

HINT11A

2021-2022

I Degree

Syllabus for B.A. , B.Com. , B.Sc.

I Semester- Hindi

TEXTBOOK	GADYA SANDESH
1.गद्य संदेश	1.साहित्य की महत्ता 2.सच्ची वीरता 3.मित्रता
2.कथा लोक	1.मुक्तिधन 2.गूढ़ साईं 3.उसने कहा था।
3.व्याकरण	कार्यालयीन हिंदी शब्दावली (हिंदी से अंग्रेजी में बदलना तथा अंग्रेजी से हिंदी में बदलना।) लिंग वचन विलोम शब्द काल वाक्य शुद्ध कीजिए
4.पत्र-लेखन	पत्र-लेखन (मित्र को पत्र, पिताजी को पत्र)

A.G. & S.G. SIDDHARTHA SCIENCE & ARTS DEGREE COLLEGE, VUYYURU.

An Autonomous College in the jurisdiction of Krishna University, Machilipatnam.

HINDI

HINT11A

2021-2022

I Degree

MODEL QUESTION PAPER

Time:3 hrs

Semester-1

Max.Marks:75

Hindi

PART-A

Answer the following questions

I निम्न लिखित प्रश्नों में से किन्हीं पाँच प्रश्नों का उत्तर दीजिए । 5x5=25

1. साहित्य की जीवन में क्या आवश्यकता है ? साहित्य द्वारा सभ्यता की परीक्षा किस प्रकार हो सकती है ?
2. वीरता किसे कहते हैं सच्ची वीरता तथा झूठी वीरता का क्या अंतर है ?
3. भारतीय इतिहास में आदर्श मित्रता के कुछ उदाहरण दीजिए ?
4. मुक्तिधन कहानी की विशेषताएँ बताइए ?
5. गूदड़ साई कहानी का उद्देश्य क्या है ?
6. नीचे दिए गए शब्दों का वचन बदलिए ।
1. लड़की 2. वीर 3.सेना 4.रूपया 5.कविता
7. काल किसे कहते हैं तथा उसके कितने प्रकार हैं ?
8. नीचे दिए गए शब्दों का लिंग बदलिए ।
1.विद्वान 2.अध्यापक 3.मोर 4.ठाकुर 5.धोबी

PART-B

5x10=50

9. साहित्य की महत्ता पाठ का सारांश लिखिए ।

(अथवा)

सच्ची वीरता पाठ का सारांश लिखिए ।

10. मुक्तिधन कहानी का सारांश लिखिए ।

(अथवा)

गूदड़ साईं कहानी का सारांश लिखिए ।

11. किन्हीं पाँच शब्दों को अंग्रेजी से हिन्दी में अनुवाद कीजिए ।

1. Acceptance 2. Ballot Officer 3. Chairman 4. Duty 5. Supervisor

6. High Court 7. Fair Copy 8. Eligibility 9. Passport 10. Accountant

(अथवा)

वाच्य किसे कहते हैं तथा वाच्य के प्रकारों के बारे में स्पष्ट कीजिए ।

12. किन्हीं पाँच शब्दों का उल्टे शब्द लिखिए ।

1. वीरता 2. अघ्य 3. नया 4. आना 5. दिन 6. सस्ता 7. मित्र 8. लेना

(अथवा)

वाक्य शुद्ध कीजिए ।

1. मोहन पुस्तक पढ़ा ।

2. सीता ने चार आम खाया ।

3. राम ने गया ।

4. दशरथ की तीन रानियाँ थी ।

5. चोरी कौन किया ?

13. हिन्दी सीखने की आवश्यकता बताते हुए अपने मित्र को एक पत्र लिखिए ।

(अथवा)

पैसे माँगते हुए अपने पिताजी को एक पत्र लिखिए ।



**A.G & S.G.SIDDHARTHA DEGREE COLLEGE OF
ARTS & SCIENCE**

Vuyyuru-521165.

NAAC reaccredited at 'A' level

Autonomous -ISO 9001 – 2015 Certified

Title of the Paper: GENERAL HINDI

Semester: III

Course Code	HIN-301	Course Delivery Method	Class Room / Blended Mode - Both
Credits	4	CIA Marks	30
No. of Lecture Hours / Week	4	Semester End Exam Marks	70
Total Number of Lecture Hours	60	Total Marks	100
Year of Introduction :2020-21	Year of Offering: 2021 - 22	Year of Revision: --- 2021-22	Percentage of Revision:10%

HINDI	HIN-301C	2021-22	B.A., B.Com., & B.Sc.
-------	----------	---------	-----------------------

SEMESTER-III

Credits – 4

HINDI - III

COURSE OUTCOMES:

- CO1 - दोहों के द्वारा विध्यार्थियों में समाज सुधारता, मानव मूल्य बढ़ते हैं ।
CO2 - हिन्दी साहित्य का इतिहास के द्वारा हिन्दी भाषा की प्रामुख्यता और कविताओं की प्रामुख्यता मिल जाती हैं ।
CO3 - समाज कल्याण विषयों को समझकर अपना ज्ञान बढ़ाते हैं ।
CO4 - समाज में भाषा पर प्रामुख्यत, भाषा में ज्ञान प्राप्त करके, दूसरों से आसानी से संप्रोषित करना सीखेंगे ।
CO5 - सरकारी व्यवस्थाओं को लेख लिखना, भाषा की विशेषता, समाज में सरकारी भाषा सीखकर दूसरों को आदर्शवान बन सकेंगे ।

I. काव्य दीप :

- कबीरदास - साखी - 1-10,
सूरदास - बालवर्णन,
मात्रु भूमि - मैथिलीशरण गुप्त,
तोडती पत्थर - सूर्यकांत त्रिपाठी निराला
मातृभाषा के प्रति : भारतेन्दु हरिश्चंद्र ।

II. हिन्दी साहित्य का इतिहास :

- काल विभाजन-आचार्य रामचन्द्र शुक्ल जी के अनुसार,
भक्ति काल: ज्ञानाश्रयी शाखा - कबीर,
प्रेमाश्रयी शाखा - जायसी

III. साधारण निबन्ध : समाचार पत्र, पर्यावरण और प्रदूषण, बैकारी की समस्या, कंप्यूटर

IV. अनुवाद : अनुवाद

V. प्रयोजनमूलक हिन्दी : परिपत्र, कार्यालय ज्ञापन, राष्ट्रभाषा हिन्दी

Recommended Books:

1. गद्य संदेश - Dr. V.L.Narasimham Siva Koti
2. कथा लेक - Dr. Ghana Shyam

A.G. & S.G. SIDDHARTHA SCIENCE & ARTS DEGREE COLLEGE, VUYURU
An Autonomous College in the jurisdiction of Krishna University, Machilipatnam

Hindi	Hindi - 301 C	2020-2021	II Degree
Syllabus for B.A., B.Com., B.Sc			
III Semester - Hindi			

पाठ्य पुस्तक	=	काव्य दीप
A) पुरानी कविता	=	1. कबीरदास साखी 2. सुरदास का बाल वर्णन
B) आधुनिक कविता	=	1. मातृभूमि 2. तोडती पत्थर 3. मातृभाषा के प्रति
C. हिन्दी साहित्य का इतिहास	-	भक्तिकाल 1. ज्ञानाश्रयी शाखा- कबीरदास 2. प्रेमाश्रयी शाखा - जायसी
D) सामान्य निबंध		1. सामाचार पत्र 2. बेकारी की समस्या 3. कंप्यूटर 4. पर्यावरण और प्रदूषण 5. साहित्य और समाज
E) अनुवाद	=	अंग्रेजी से हिन्दी 5 sentences from prescribed text book
F) कार्यालय हिन्दी	=	1. परिपत्र 2. ज्ञापन 3. सूचना

A.G. & S.G. SIDDHARTHA SCIENCE & ARTS DEGREE COLLEGE, VUYYURU
An Autonomous College in the jurisdiction of Krishna University, Machilipatnam

Hindi	Hindi - 301 C	2020-2021	II Degree
-------	---------------	-----------	-----------

MODEL QUESTION PAPER

Time : 3 Hours	III Semester	Max. Marks : 75
	Hindi	Pass Mark : 30

1. **निम्न लिखित पद्यांशों में से किसी एक की सप्रसंग व्याख्या कीजिए ।**

1 x 10 = 10

A) पाहन पूजे हरिमिलै, तो मैं पूजूँ पहार ।

ताते ये चाकी भली, पीस खाय संसार ॥

अथवा

B) सोभित कर नवनीत लिए ।

घुटुरुनि चलत रेनु-तन-मंडित, मुख दधि लेप किए ।

चारु कपोल, लोल लोचन, गोरोचन तिलक दिए ।

लट-लटकनि मनमत्त मधुप-गत मादक मधुहिं पिए ।

2. **निम्न लिखित पद्यांशों में से किसी एक की सप्रसंग व्याख्या कीजिए ।**

1 x 10 = 10

A) उन्नति पूरी है तब हि जब घर उन्नति होय ।

निज शरीर उन्नति किय, रहत मूढ सब कोय ॥

निज भाषा उन्नति बिना कबहुँ न हौ हैं सोच ।

लाख उपाय अनेक यों भले करो किन कोय ॥

अथवा

B) पालन - पोषण और जन्म का कारण तूही,

वक्षस्थल पर हमें कर रही धारण तू ही ।

अभ्रंकश प्रासाद और ये महल हमारे ।

बने हुए हैं अहो! तुझी से तुझ पर सारे ।

3. **किसी एक कविता का सारांश लिखिए ।**

1 x 13 = 13

A) तोडती पत्थर

अथवा

B) मातृभाषा के प्रति

4. किसी एक साहित्यक विषय पर विश्लेषणात्मक निबंध लिखिए । 1 x 13=13
- A) ज्ञानाश्रयी शाखा के बारे में वर्णन करते हुए कबीर का स्थान निर्धारित कीजिए ।
- अथवा
- B) प्रेमाश्रयी शाखा के बारे में वर्णन करते हुए जायसी का स्थान निर्धारित कीजिए ।
5. किसी एक विषय पर निबंध लिखिए । 1 x 9=9
- A) समाचार पत्र
B) बेकारी की समस्या
C) पर्यावरण और प्रदूषण
6. निम्न लिखित में से किसी एक का उत्तर दीजिए । 1x5=5
- A) सूरदास
B) सूर्यकान्त त्रिपाठी 'निराला'
7. हिन्दी में अनुवाद कीजिए । 1x5=5
- A) As soon as he reached the station, the train left.
B) Swamy Vivekananda was a great saint.
C) Kabirdas travelled through out the country.
D) There is a temple behind the tree.
E) Kalidas is known as the Shakespeare of India.
8. निम्न लिखित में से किसी एक की टिप्पणी लिखिए । 1x5=5
- A) परिपत्र
B) ज्ञापन
C) सूचना

A.G. & S.G. SIDDHARTHA SCIENCE & ARTS DEGREE COLLEGE, VUYURU
An Autonomous College in the jurisdiction of Krishna University, Machilipatnam
Department of Hindi
II Degree - III semester
Guidelines for the question paper setter

Time : 3 Hours

HIN - 301 C

Max. Marks : 75

Pass Marks : 30

Note : The question paper setters are requested to

I. Keep the assignment strictly confidential.

II. Please go through the syllabus and the model question paper supplied.

1. Two annotations to be set from old poetry lessons of which one question to be answered. 1 x 10=10
2. Two annotations to be set from modern poetry lessons of which one question to be answered. 1 x 10=10
3. Two essays to be set from modern poetry lessons of which one to be answered. 1 x 15=15
4. Two essays to be set from history of hindi literature of which one to be answered. 1 x 15=15
5. Three general essays to be set, one to be answered. 1 x 10=10
6. Two short questions to be set one from old poetry and one from modern poetry one to be answered. 1 x 5=5
7. Translation from English to Hindi. 1 x 5=5
5 simple sentences to be set 5 to be answered. - No choice.
8. Three short questions to be set from prayojan moolak hindi one question to be answered. 1 x 5=5

* * *

III Semester

English to Hindi

1. The temple is on the bank of the Tree.
2. Mother land is the mother of all mothers.
3. Service to man is service to god.
4. Although he is poor, yet he is honest.
5. As soon as he reached the station, the train left.
6. The murderer was caught red-handed.
7. Religion is the foundation of human society.
8. Milk contains all essential nutrients.
9. A scholar is respected every where.
10. Contentment is greatest happiness.
11. Trees keep the atmosphere cool.
12. A book is treasure house of knowledge.
13. India is a secular and socialistic country.
14. The cow gives milk.
15. He is a poor, but not thief.
16. Peacock is the beautiful bird.
17. Beauty is truth.
18. Rama has eaten bread.
19. We have to read news papers daily.
20. Rama is taller than Krishna.
21. Swamy Vivekananda was a great philosopher.
22. We must respect our elders.
23. Most of people of our country live in villages.
24. Be grateful to your parents.
25. Kalidas is known as the Shakespeare of India.

AG & SG Siddhartha Degree College of Arts & Science (Autonomous)

Vuyyuru – 521165, Krishna District, AP.

Accredited 'A' Grade by NAAC



Department of Mathematics

Minutes of the meeting of Board of Studies

10-11-2021

**Minutes of the meeting of BOS in Mathematics for B.Sc Degree Courses of
AG & SG Siddhartha Degree College of Arts & Science, Vuyyuru, held at 2.30
PM on 10 – 11 – 2021.**

N.V. Srinivasa Rao

Presiding

Members Present:

- | | | |
|--|-----------------------|---|
| 1) <u><i>N.V. Srinivasa Rao</i></u>
(N.V. Srinivasa Rao) | Chairman | Head, Department of
Mathematics,
AG & SG S Degree College. |
| 2) <u><i>K. Jaya Lakshmi</i></u>
(Dr. K. Jaya Lakshmi) | University
Nominee | Department of Mathematics,
Krishna University,
Machilipatnam. |
| 3) <u><i>M. Venkateswara Rao</i></u>
(M. Venkateswara Rao) | Subject
Expert | Department of Mathematics,
Govt. Degree College,
Avanigadda. |
| 4) <u><i>I.V. Venkateswara Rao</i></u>
(I. V. Venkateswara Rao) | Subject
Expert | Department of Mathematics,
P. B. Siddhartha College,
Vijayawada |
| 5) <u><i>D. Sunitha</i></u>
(D. Sunitha) | Member | Lecturer in Mathematics
AG & SG S Degree College. |
| 6) <u><i>A. Bhargavi</i></u>
(A. Bhargavi) | Member | Lecturer in Mathematics
AG & SG S Degree College. |
| 7) <u><i>Noor Mohammad</i></u>
(Noor Mohammad) | Member | Lecturer in Mathematics
AG & SG S Degree College. |
| 8) <u><i>K. Rajya Lakshmi</i></u>
(K. Rajya Lakshmi) | Member | Lecturer in Mathematics
AG & SG S Degree College. |
| 9) <u><i>B. Durga Praveen</i></u>
(B. Durga Praveen) | Student
Member | III B.Sc M.C.Cs
AG & SG S Degree College. |
| 10) <u><i>M. Rose Manasa</i></u>
(M. Rose Manasa) | Student
Member | III B.Sc M.P.C (E)
AG & SG S Degree College. |

Agenda of B.O.S Meeting:

1. To discuss and recommend the Syllabi, Model Question Papers and Guidelines to be followed by question paper setters in Mathematics for 1st Semester as per the guidelines and instructions under CBCS prescribed by Krishna University from the Academic Year 2021-22.
2. To discuss and recommend the Syllabi, Model Question Papers and Guidelines to be followed by question paper setters in Mathematics and Analytical Skills for 3rd Semester as per the guidelines and instructions under CBCS prescribed by Krishna University from the Academic Year 2021-22.
3. To discuss and recommend the Syllabi, Model Question Papers and Guidelines to be followed by question paper setters in Mathematics for 5th Semester as per the guidelines and instructions under CBCS prescribed by Krishna University from the Academic Year 2021-22.
4. Any other matter.

Resolutions.

1. Discussed and recommended that changes are required in Syllabi, Model Question Papers and Guidelines to be followed by the question paper setters in Mathematics for 1st Semesters from the Academic year 2021-22. The maximum marks for IA is 25 and SE is 75. Each IA written examination is of 1 Hr. 30 min duration for 20 marks. The tests will be conducted centrally. The average of two such IA is calculated for 20 marks. 5 marks will be allotted basing on Assignment. There is no minimum passing for IA and there is no provision for improvement in IA. Even though the candidate is absent for two IA exams/obtain zero marks the external marks are considered (if he/ she gets 40 out of 75) and the result shall be declared as 'PASS' from the Academic year 2021-22.
2. Discussed and recommended that changes are required in Syllabi, Model Question Papers and Guidelines to be followed by the question paper setters in Mathematics and Analytical Skills for all degree programs of 3rd Semesters from the Academic year 2021-22. The maximum marks for IA is 30 and SE is 70. Each IA written examination is of 1 Hr. 30 min duration for 20 marks. The tests will be conducted centrally. The average of two such IA is calculated for 20 marks. 5 marks will be allotted basing on Assignment and 5 marks are allotted for attendance. There is no minimum passing for IA and there is no provision for improvement in IA. Even though the candidate is absent for two IA exams/obtain zero marks the external marks are considered (if he/ she gets 40 out of 70) and the result shall be declared as 'PASS' from the Academic year 2021-22. There is no IA for Analytical Skills and minimum pass marks is 20 out of 50 in SE.
3. Discussed and recommended that no changes are required in syllabi, Model Question Papers and Guidelines for question paper setters in Mathematics for the 5th Semester for the Academic year 2021-22.
4. Discussed and recommended for organizing seminars, Guest lecturers, Online Examinations and Workshops to upgrade the knowledge of students for Competitive Examinations for the approval of the Academic Council.

N.V. Srinivasan
Chairman

University Nominee

M. Venkateswaraiah
Subject Expert

G.V. Venkateswaraiah
Subject Expert

A . G & S . G Siddhartha Degree College of Arts and Science (Autonomous), Vuyyuru

(An Autonomous College in the jurisdiction of Krishna University, Machilipatnam)

NAAC reaccruited at 'A' level *ISO 9001 – 2015 Certified***Department of Mathematics****COURSE STRUCTURE****Paper Title: - DIFFERENTIAL EQUATIONS****Semester : I**

Course Code	MATT11A	Course Delivery Method	Class Room / Blended Mode - Both
Credits	5	CIA Marks	25
No. of Lecture Hours / Week	6	Semester End Exam Marks	75
Total Number of Lecture Hours	60	Total Marks	100
Year of Introduction :2018-19	Year of Offering: 2021 - 22	Year of Revision: 2021 - 22	Percentage of Revision: 0%

Programme Outcomes

S. No	P.O
	At the end of the Programme the student will be able to:
1	Demonstrate the ability to use mathematical skills such as formulating and tackling mathematics related problems and identifying and applying approximate physical principles and methodologies to solve a wide range of problems associated with mathematics.
2	Apply the underlying unifying structures of mathematics and the relationships among them.
3	Investigate and apply mathematical problems and solutions in variety of contexts related to science and technology, business and industry.

Course Outcomes of MATT11A

S. No	C.O	Mapping
	Upon successful completion of this course, students should have the knowledge and skills to:	
1	Determine the solution of differential equations of the first order and of the first degree by Exact, Linear and Bernoulli's method.	L2, PO – 1
2	Understand the basic concepts of first order differential equations to find Orthogonal trajectories.	L2, PO - 1
3	Determine the solution of differential equations of the first order and of a degree higher than first by using methods of solvable for P, X, and Y.	L2,PO - 1
4	Compute all solutions of second and higher order linear differential equations with constant coefficients, linear equations with variable coefficients.	L3, PO – 1
5	Calculate the solutions of higher order differential equations by Cauchy Euler and Variation of parameters.	L2, PO – 1

A . G & S . G Siddhartha Degree College of Arts and Science (Autonomous), Vuyyuru

(An Autonomous College in the jurisdiction of Krishna University, Machilipatnam)

MATHEMATICS	MAT T11A	2021 – 22 onwards	B.Sc (MPC, MPCS, MCCS, MSCS)
--------------------	-----------------	--------------------------	-------------------------------------

DIFFERENTIAL EQUATIONS

SEMESTER-I

No of Credits: 5

OBJECTIVES:

1. Understand all of the concepts relating to the order and linearity of ODEs, analytic and computational solution methods for ODEs, and the real-world applications of ODEs.
2. Apply your understanding of the concepts, formulas, and problem-solving procedures to thoroughly investigate relevant physical models.
3. Explain the concepts of linear systems, ODE solution methods, and related ideas at a fundamental level, as well as how and why we use the solution techniques that we use.

UNIT-I: DIFFERENTIAL EQUATIONS OF FIRST ORDER & FIRST DEGREE (12Hrs)

- 1.1 Linear Differential Equations
- 1.2 Differential Equations Reducible to Linear Form, Bernoulli's differential equations.
- 1.3 Exact Differential Equations
- 1.4 Integrating Factors, $1/Mx+Ny$, $1/Mx-Ny$, $e^{\int f(x)} dx$, $e^{\int g(y)} dy$, and Inspection method
- 1.5 Change of Variables

UNIT-II: ORTHOGONAL TRAJECTORIES & DIFFERENTIAL EQUATIONS OF FIRST ORDER BUT NOT FIRST DEGREE (12Hrs)

- 2.1 Orthogonal Trajectories
- 2.2 Self-Orthogonal Trajectories
- 2.3 Equations solvable for p
- 2.4 Equations solvable for y
- 2.5 Equations solvable for x
- 2.6 Equations Homogeneous in X & Y
- 2.7 Equations that do not contain x (or y)
- 2.8 Clairaut's Equation and Equations reducible to Clairaut's form.

UNIT – III: Higher order linear differential equations-I (12Hrs)

- 3.1 Solution of homogeneous linear differential equations of order n with constant coefficients
- 3.2 Solution of the non-homogeneous linear differential equations with constant coefficients by means of polynomial operators.
- 3.3 General Solution of $f(D)y=0$
- 3.4 General Solution of $f(D)y=Q$ when Q is a function of x.
- 3.5 $1/f(D)$ is Expressed as partial fractions.
- 3.6 P.I. of $f(D) y = Q$ when $Q = be^{ax}$
- 3.7 P.I. of $f(D) y = Q$ when Q is $b \sin ax$ or $b \cos ax$.

UNIT – IV: Higher order linear differential equations-II (12Hrs)

- 4.1 Solution of the non-homogeneous linear differential equations with constant coefficients.
- 4.2 P.I. of $f(D) y = Q$ when $Q = bx^k$
- 4.3 P.I. of $f(D) y = Q$ when $Q = e^{ax}V$
- 4.4 P.I. of $f(D) y = Q$ when $Q = xV$
- 4.5 P.I. of $f(D) y = Q$ when $Q = x^mV$ where $v = \sin bx$ and $\cos bx$

UNIT-V: Higher order Differential Equations –III (12Hrs)

- 5.1 The Cauchy-Euler Equation.
- 5.2 Linear differential Equations with non-constant coefficients
- 5.3 Method of Variation of parameters.

Student Activities:

- 1) **Class-room activities:** Power point presentations, Assignments
- 2) **Library activities:** Visit to library and preparation of notes for Assignment problems.
- 3) **Activities in the Seminars, workshops and conferences:** Participation/presentation in seminar/workshop/conference.

CO-CURRICULAR ACTIVITIES:

- Quiz Competitions, Seminars
- Group Discussions

WEB LINKS:

https://en.wikipedia.org/wiki/Differential_equation

<https://tutorial.math.lamar.edu/classes/de/de.aspx>

<https://www.mathsisfun.com/calculus/differential-equations.html>

Prescribed Text book:				
S.NO	AUTHOR	TITLE OF THE BOOK	PUBLISHER	YEAR OF PUBLICATION
1	V. Krishna Murthy	A text book of Mathematics for B.A/B.ScVol – I	S-Chand&co	2015

Reference books:				
S.NO	AUTHOR	TITLE OF THE BOOK	PUBLISHER	YEAR OF PUBLICATION
1	Dr.A. Anjaneyulu	A text book of mathematics for B.A/B.ScVol – I	Deepthi Publications	2015
2	Rai Singhanian	Ordinary& Partial Differential Equations	S-Chand	2009
3	Zafar Ahsan	Differential Equations and their applications	Prentice-Hall of India Pvt Ltd, McGraw Hill	2000

Recommended Question Paper Pattern and Model BLUE PRINT FOR QUESTION PAPER
PATTERN COURSE-I, DIFFERENTIAL EQUATIONS

Unit	TOPIC	S.A.Q(including choice)	E.Q(including choice)	Total Marks
I	Differential Equations of 1 st order and 1 st degree	2	2	30
II	Orthogonal Trajectories, Differential Equations of 1 st order but not of 1 st degree	2	2	30
III	Higher Order Linear Differential Equations (with constant coefficients) – I	1	2	25
IV	Higher Order Linear Differential Equations (with constant coefficients) – II	2	2	30
V	Higher Order Linear Differential Equations (with non-constant coefficients)	1	2	25
TOTAL		8	10	140

S.A.Q. = Short answer questions (5 marks)

E.Q. = Essay questions (10 marks)

Short answer questions : 5 X 5 M = 25 M

Essay questions : 5 X 10 M = 50 M

.....

Total Marks = 75 M

.....

COURSE-I DIFFERENTIAL EQUATIONS

B.Sc MATHEMATICS MODEL PAPER

Time: 3hrs.

Max. Marks: 75

Section – A

Answer any FIVE questions

5x5=25

1. Determine the solution of $2xy \, dy - (x^2 + y^2 + 1) \, dx = 0$ (CO1,L2)
2. Determine the solution of $x \frac{dy}{dx} + 2y - x^2 \log x = 0$ (CO1, L2)
- 3 Find the orthogonal trajectories of the family of $r = a(1 - \cos \theta)$ where a is a parameter. (CO2, L2)
- 4 Solve $x = y + p^2$ (CO3,L2)
- 5 Compute the C.F of $(D^3 + 3D^2 + 3D + 1) y = e^{5x}$ (CO4,L3)
6. Compute the P.I of $(D^3 + 4D)y = \sin 2x$ (CO4,L3)
7. Determine the solution of $d^2 y/dx^2 + y = \text{Cosec } x$ by variation of parameters. (CO5,L2)
8. Determine the solution of $\frac{d^2 y}{dx^2} - \cot x \frac{dy}{dx} - (1 - \cot x)y = e^x \sin x$ (CO4,L3)

Section – B

Answer ALL the questions.

(5 x 10 = 50 marks)

Unit – I

9. Determine the solution of $x(1 + xy) \, dy + y(1 - xy) \, dx = 0$ (CO1, L2)
(OR)
10. Determine the solution of $x \frac{dy}{dx} + y = y^2 \log x$ (CO1, L2)

Unit – II

11. Find the orthogonal trajectories of the family of curves $x^{2/3} + y^{2/3} = a^{2/3}$, where 'a' is the parameter. (CO2, L2)
(OR)
12. Determine the solution of $y + px = p^2 x^4$ (CO3, L2)

Unit – III

13. Determine the solution of $(D^2 + 4D + 4)y = e^{4x}$ (CO4, L3)
(OR)

14. Determine the solution of $(D^2 - 2D + 3)y = \cos 2x$ (CO4, L3)

Unit – IV

15. Determine the solution of $\frac{d^2y}{dx^2} - 6\frac{dy}{dx} + 13y = 8e^{3x} \sin 2x$ (CO4, L3)
(OR)

16. Determine the solution of $(D^4 + 2D^2 + 1)y = x^2 \cos x$ (CO4, L3)

Unit – V

17. Determine the solution of $[(x-1)D^2 - xD + 1]y = (x-1)^2$ by variation of parameters. (CO5, L2)
(OR)

18. Determine the solution of $(x^2D^3 + 2x^3D^2 - x^2D^2 + x)y = 1$ (CO5, L2)

A. G & S. G Siddhartha Degree College of Arts and Science (Autonomous), Vuyyuru

(An Autonomous College in the jurisdiction of Krishna University, Machilipatnam)

NAAC reaccredited at 'A' level

Autonomous -ISO 9001 – 2015 Certified

Title of the Paper: ABSTRACT ALGEBRA

Semester: III

Course Code	MAT - 301	Course Delivery Method	Class Room / Blended Mode - Both
Credits	5	CIA Marks	30
No. of Lecture Hours / Week	6	Semester End Exam Marks	70
Total Number of Lecture Hours	75	Total Marks	100
Year of Introduction :2021-22	Year of Offering: 2021 - 22	Year of Revision: ----	Percentage of Revision: 0%

Course Outcomes:

After successful completion of this course, the student will be able to;

1. Acquire the basic knowledge and structure of groups, subgroups and cyclic groups.
2. Get the significance of the notation of a normal subgroups.
3. Get the behavior of permutations and operations on them.
4. Study the homomorphisms and isomorphisms with applications.
5. Understand the ring theory concepts with the help of knowledge in group theory and to prove the theorems.
6. Understand the applications of ring theory in various fields.

Course Syllabus:

UNIT – I: GROUPS:

(12 Hours)

Binary Operation – Algebraic structure – semi group- monoid – Group definition and elementary properties

Finite and Infinite groups – examples – order of a group, Composition tables with examples.

UNIT – II: SUB - GROUPS:

(12 Hours)

Complex Definition – Multiplication of two complexes Inverse of a complex-Subgroup definition- examples- criterion for a complex to be a subgroups. Criterion for the product of two subgroups to be a subgroup-union and Intersection of subgroups.

Co-sets and Lagrange's Theorem :

Cosets Definition – properties of Cosets–Index of a subgroups of a finite groups–Lagrange's Theorem.

UNIT –III: NORMAL SUBGROUPS :

(12 Hours)

Definition of normal subgroup – proper and improper normal subgroup–Hamilton group – criterion for a subgroup to be a normal subgroup – intersection of two normal subgroups – Sub group of index 2 is a normal sub group –quotient group – criteria for the existence of a quotient group.

HOMOMORPHISM :

Definition of homomorphism – Image of homomorphism elementary properties of homomorphism – Isomorphism – automorphism definitions and elementary properties–kernel of a homomorphism – fundamental theorem on Homomorphism and applications.

UNIT – IV: PERMUTATIONS AND CYCLIC GROUPS : (12 Hours)

Definition of permutation – permutation multiplication – Inverse of a permutation – cyclic permutations – transposition – even and odd permutations – Cayley’s theorem.

Cyclic Groups :- Definition of cyclic group – elementary properties – classification of cyclic groups.

UNIT – V: RINGS : (12 Hours)

Definition of Ring and basic properties, Boolean Rings, divisors of zero and cancellation laws Rings, Integral Domains, Division Ring and Fields, The characteristic of a ring - The characteristic of an Integral Domain, The characteristic of a Field. Sub rings and Ideals (only definitions)

Co-Curricular Activities (15 Hours)

Seminar/ Quiz/ Assignments/ Group theory and its applications / Problem Solving.

Text Book:

A text book of Mathematics for B.A. / B.Sc. by B.V.S.S. SARMA and others, published by S.Chand & Company, New Delhi.

Reference Books:

1. Abstract Algebra by J.B. Fraleigh, Published by Narosa publishing house.
2. Modern Algebra by M.L. Khanna.
3. Rings and Linear Algebra by Pundir & Pundir, published by Pragathi Prakashan.

A . G & S . G Siddhartha Degree College of Arts and Science (Autonomous), Vuyyuru

(An Autonomous College in the jurisdiction of Krishna University, Machilipatnam)

SEMESTER - III, ABSTRACT ALGEBRA

B.Sc MATHEMATICS MODEL PAPER

Time: 3Hrs

Max.Marks:70M

SECTION - A

Answer any FOUR questions. Each question carries FIVE marks. Choosing at least ONE question from each part. 4 X 5 M=20 M.

Part – 1

1. Show that the set $G = \{x/ x = 2^a, 3^b \text{ and } a, b \in \mathbb{Z}\}$ is a group under multiplication.
2. Define order of an element of a Group. In a group G if $a \in G$ then $O(a) = O(a^{-1})$.
3. If H and K are two subgroups of a group G , then prove that HK is a subgroup of G If and only if $HK=KH$
4. If G is a group and H is a subgroup of index 2 in G then prove that H is a normal subgroup.

Part – 2

5. The necessary and sufficient condition for a homomorphism f of a group G on to a group G^1 with kernel K to be an isomorphism of G into G^1 is that $K = \{e\}$
6. Examine whether the following permutations are even or odd
i) $\begin{pmatrix} 1 & 2 & 3 & 4 & 5 & 6 & 7 & 8 & 9 \\ 6 & 1 & 4 & 3 & 2 & 5 & 7 & 8 & 9 \end{pmatrix}$ ii) $\begin{pmatrix} 1 & 2 & 3 & 4 & 5 & 6 & 7 \\ 3 & 2 & 4 & 5 & 6 & 7 & 1 \end{pmatrix}$
7. Prove that a group of prime order is cyclic.
8. Every field is an integral domain.

SECTION - B

Answer any FIVE questions. Each question carries TEN marks. Choosing at least TWO question from each part 5 X 10 M = 50 M

Part – 1

9. Show that the set Q_+ of all +ve rational numbers forms an abelian group under the composition defined by “o” such that $aob = ab/3$ for $a, b \in Q_+$
10. Show that the set of n^{th} roots of unity forms an abelian group under multiplication.
11. The Union of two subgroups is also a subgroup \Leftrightarrow one is contained in the other.
12. State and prove Lagrange’s theorem.

Part – 2

13. Prove that a subgroup H of a group G is a normal subgroup of G iff the product of two right coset of H in G is again a right coset of H in G .
14. State and prove fundamental theorem of homomorphisms of groups.
15. Prove that every subgroup of cyclic group is cyclic.
16. Prove that the characteristic of an integral domain is either prime or zero.

BLUE PRINT FOR QUESTION PAPER PATTERON COURSE-III, ABSTRACT ALGEBRA

Un i t	TOPIC	S.A.Q(including choice)	E.Q(including choice)	Total Marks
I	Groups	2	2	30
II	Subgroups, Cosets & Lagrange's theorem	1	2	25
III	Normal Subgroups and Homomorphism	2	2	30
IV	Permutations and Cyclic groups	2	1	20
V	Rings	1	1	15
Total		8	8	120

S.A.Q. = Short answer questions (5 marks)

E.Q. = Essay questions (10 marks)

Short answer questions : 4 X 5 M = 20 M

Essay questions : 5 X 10 M = 50 M

.....

Total Marks = 70 M

A.G &S.G SIDDHARTHA DEGREE COLLEGE, VUYYURU-521165
(An Autonomous College in the jurisdiction of Krishna University, Machilipatnam)

MATHEMATICS MAT-501C w.e.f 2020-21 III B.Sc (MPC, MPCs, MCCs)

SEMESTER-V

PAPER-V

Max.Marks:70

Hours/ Week: 5

No. of Credits: 5

VECTOR CALCULUS & RING THEORY

UNIT – 1: VECTOR DIFFERENTIATION: - (12 hrs)

Vector Differentiation, Ordinary derivatives of vectors, Differentiability, Gradient, divergence, Curl operators, Formulae Involving these operators.

UNIT – 2: VECTOR INTEGRATION: - (12 hrs)

Line Integral, Surface Integral and Volume integral with examples.

UNIT – 3: VECTOR INTEGRATION APPLICATIONS: - (12 hrs)

Theorems of Gauss and Stokes, Green's theorem in plane and applications of these theorems.

UNIT – 4: RINGS-I: - (12 hrs)

Definition of Ring and basic properties, Boolean Rings, divisors of zero and cancellation laws Rings, Integral Domains, Division Ring and Fields, The characteristic of a ring – The characteristic of an Integral Domain, The characteristic of a Field. Sub Rings, Ideals

UNIT – 5: RINGS-II: - (12 hrs)

Definition of Homomorphism – Homomorphic Image – Elementary Properties of Homomorphism – Kernel of a Homomorphism – Fundamental theorem of Homomorphism
Maximal Ideals – Prime Ideals.

Reference Books:-

1. Abstract Algebra by J. Fraleigh, Published by Narosa Publishing house.
2. Vector Calculus by Santhi Narayana, Published by S. Chand & Company Pvt. Ltd., New Delhi.
3. A text Book of B.Sc., Mathematics by B.V.S.S.Sarma and others, published by S. Chand & Company Pvt. Ltd., New Delhi.
4. Vector Calculus by R. Gupta, Published by Laxmi Publications.
5. Vector Calculus by P.C. Matthews, Published by Springer Verlag publications.
6. Rings and Linear Algebra by Pundir & Pundir, Published by Pragathi Prakashan.

Suggested Activities:

Seminar/ Quiz/ Assignments/ Project on Ring theory and its applications

A.G & S.G SIDDHARTHA DEGREE COLLEGE: VUYYURU
(An Autonomous College in the jurisdiction of Krishna University, Machilipatnam)

DEPARTMENT OF MATHEMATICS

Question Paper Guidelines for SEMESTER-END Examinations

Time: 3 Hrs MAT- 501 C Max.Marks:70 Min. Mark: 28

Note :- 1) Answer any FOUR questions out of 8 in Section-A. Each question Carries 5 marks.
(4x5=20 Marks)

2) Answer any FIVE questions out of 8 in Section-B. Each question Carries 10 marks.
(5x10=50 Marks)

Questions to be set as follows:

Questions to be set as follows:

	Unit-1	Unit-2	Unit-3	Unit-4	Unit-5
<u>Section-A</u> (Short Answer Questions)	2	2	1	2	1
<u>Section-B</u> (Essay Questions)	2	1	2	2	1

-The End -

**A.G & S.G SIDDHARTHA DEGREE COLLEGE OF ARTS AND SCIENCE,
VUYYURU – 521165, KRISHNA Dt., A.P.
(An Autonomous College in the jurisdiction of Krishna University, Machilipatnam)
EXAMINATION AT THE END OF FIFTH SEMESTER (w.e.f 2020-21)**

MATHEMATICS Paper V MAT- 501C MAX.MARKS: 70 TIME: 3 hrs

(VECTOR CALCULUS AND RING THEORY)

Section – A (short answer questions)

Answer any **Four** of the following questions.

4x5 = 20M

Choosing at least **ONE** question from each Part.

Part - I

- 1) If $r = a \cos t i + a \sin t j + at \tan \theta k$ find $\left| \frac{dr}{dt} \times \frac{d^2r}{dt^2} \right|$ and $\left[\frac{dr}{dt} \frac{d^2r}{dt^2} \frac{d^3r}{dt^3} \right]$
- 2) Find $\text{div } f$ and $\text{curl } f$ where $f = \text{grad}(x^3 + y^3 + z^3 - 3xyz)$.
- 3) If $F = 3xyi - y^2j$ evaluate $\oint_c F \cdot dr$ where 'c' is the curve $y = 2x^2$ in the xy plane from (0, 0) to (1, 2).
- 4) If $F = 2xzi - xj + y^2k$ evaluate the $\int_v F \cdot dv$ where v is the region bounded by the surface $x = 0, x = 2, y = 0, y = 6, z = x^2, z = 4$.

Part - II

- 5) State and prove Green's theorem in a plane.
- 6) Prove that $Z_m = \{0, 1, 2, 3, \dots, m-1\}$ is a ring with respect to addition and multiplication modulo 'm'
- 7) Prove that a field has no Zero divisors.
- 8) If f is homomorphism of a ring R into a ring R^1 then $\text{ker } f$ is an ideal of R

Section – B (long answer questions)

Answer any **FIVE** of the following questions.

5x10 = 50M

Choosing at least TWO questions from each Part.

Part - I

- 9) Prove that $\text{grad}(A \cdot B) = (B \cdot \nabla)A + (A \cdot \nabla)B + B \times \text{curl} A + A \times \text{curl} B$.
- 10) Evaluate $\int_s F \cdot N ds$ where $F = zi + xj - 3y^2zk$ and s is the surface $x^2 + y^2 = 16$ included in the first octant between $z=0$ and $z=5$.
- 11) State and prove Gauss divergence Theorem.
- 12) Verify Green's Theorem in the plane for $\oint_c (3x^2 - 8y^2)dx + (4y - 6xy)dy$ where c is the region bounded by $y = \sqrt{x}$ and $y = x^2$.

Part - II

- 13) Find the directional derivative of the function $f = x^2 - y^2 + 2z^2$ at the point $P(1, 2, 3)$ in the direction of the line PQ where $Q = (5, 0, 4)$.
- 14) Define Field. Prove that every field is an integral domain.
- 15) Prove that $\mathbb{Q}(\sqrt{2}) = \{a + b\sqrt{2} \mid a, b \in \mathbb{Q}\}$ is a ring with respect to ordinary addition and multiplication.
- 16) State and prove fundamental theorem of ring homomorphism.

A.G & S.G SIDDHARTHA DEGREE COLLEGE: VUYYURU-521165

(An Autonomous College in the jurisdiction of Krishna University, Machilipatnam)

MATHEMATICS MAT-502C w.e.f 2020-21 III B.Sc (MPC, MPCs, MCCs)

SEMESTER-V

PAPER-VI

Max.Marks:70

Hours/ Week: 5

No. of Credits: 5

LINEAR ALGEBRA

UNIT –I Matrix:

(12 hrs)

Matrices, Elementary Properties of Matrices, Triangular form, Echelon form, Normal form Inverse Matrices, Non – Singular form, Rank of Matrix, Linear Equations, Characteristic Roots, Characteristic Vectors of square Matrix, Cayley – Hamilton Theorem.

UNIT – II Vector Spaces-I:

(12 hrs)

Vector Spaces, General properties of vector spaces, n-dimensional Vectors, addition and scalar multiplication of Vectors, internal and external composition, Null space, Vector subspaces, Algebra of subspaces, Linear Sum of two subspaces, linear combination of Vectors, Linear span Linear independence and Linear dependence of Vectors.

UNIT –III Vector Spaces-II:

(12 hrs)

Basis of Vector space, Finite dimensional Vector spaces, basis extension, co-ordinates, Dimension of a Vector space, Dimension of a subspace, Quotient space and Dimension of Quotient space.

UNIT –IV Linear Transformations:

(12 hrs)

Linear transformations, linear operators, Properties of L.T, sum and product of LTs, Algebra of Linear Operators, Range and null space of linear transformation, Rank and Nullity of linear transformations – Rank – Nullity Theorem.

UNIT –V Inner product space:

(12 hrs)

Inner product spaces, Euclidean and unitary spaces, Norm or length of a Vector, Schwartz inequality, Triangle in Inequality, Parallelogram law, Orthogonality, Orthonormal set, complete orthonormal set, Gram – Schmidt orthogonalisation process. Bessel's inequality and Parseval's Identity.

Reference Books:

1. Linear Algebra by J.N. Sharma and A.R. Vasista, published by Krishna Prakashan Mandir, Meerut- 250002.
2. Matrices by Shanti Narayana, published by S.Chand Publications.
3. Linear Algebra by Kenneth Hoffman and Ray Kunze, published by Pearson Education (low priced edition), New Delhi.
4. Linear Algebra by Stephen H. Friedberg et al published by Prentice Hall of India Pvt. Ltd. 4th Edition 2007.

Suggested Activities:

Seminar/ Quiz/ Assignments/ Project on “Applications of Linear algebra Through Computer Sciences”

A.G & S.G SIDDHARTHA DEGREE COLLEGE: VUYYURU
(An Autonomous College in the jurisdiction of Krishna University, Machilipatnam)

DEPARTMENT OF MATHEMATICS

Question Paper Guidelines for SEMESTER-END Examinations

Time: 3 Hrs MAT- 502 C Max.Marks:70 Min. Mark: 28

Note :- 1) Answer any FOUR questions out of 8 in Section-A. Each question Carries 5 marks. (4x5=20 Marks)

2) Answer any FIVE questions out of 8 in Section-B. Each question Carries 10 marks. (5x10=50 Marks)

Questions to be set as follows:

Questions to be set as follows:

	Unit-1	Unit-2	Unit-3	Unit-4	Unit-5
<u>Section-A</u> (Short Answer Questions)	2	1	1	2	2
<u>Section-B</u> (Essay Questions)	2	1	1	2	2

-The End -

EXAMINATION AT THE END OF FIFTH SEMESTER (w.e.f 2020-21)

MATHEMATICS Paper VI MAT- 502C MAX.MARKS: 70 TIME: 3 hrs

LINEAR ALGEBRA

Section – A (short answer questions)

Answer any Four of the following questions.

4x5 = 20M

Choosing at least ONE question from each Part.

Part - I

1) Show that the rank of the transpose of a matrix is equal to the rank of the original matrix. i.e., $\rho(A) = \rho(A^T)$.

2) Find the rank of the matrix $\begin{bmatrix} 1 & -2 & 2 & -3 \\ 4 & 1 & 0 & 2 \\ 0 & 3 & 0 & 4 \\ 0 & 1 & 0 & 2 \end{bmatrix}$ by reducing it in the Normal form

3) If S is a subset of a vector space V(F), then prove that S is a subspace of V $\Leftrightarrow L(S) = S$

4) Let w_1 and w_2 be two subspaces of R^4 given by $w_1 = \{(a,b,c,d) ; b-2c+d=0\}$,

$w_2 = \{(a,b,c,d); a=d, b=2c\}$. Find the basis and dimension (i) w_1 (ii) w_2 (iii) $w_1 \cap w_2$

and hence find the $dim(w_1 + w_2)$

Part - II

5) Let $T: R^2 \rightarrow R^2$ be a linear transformation defined by $T(1,0)=(1,1), T(0,1)=(-1,2)$ then find a linear transformation T

6) The mapping $T: V_3(R) \rightarrow V_2(R)$ is defined by $T(x, y, z) = (x - y, x - z)$ is a linear transformation.

7) State and prove Cauchy – Schwarz’s inequality

8) State and prove Triangle inequality

Section – B (long answer questions)

Answer any **FIVE** of the following questions.

5x10 = 50M

Choosing at least TWO questions from each Part.

Part - I

- 9) State and prove Cayley – Hamilton theorem in Matrices.
- 10) Find the characteristic roots and the corresponding characteristic vectors of the matrix

$$A = \begin{bmatrix} 1 & 4 \\ 3 & 2 \end{bmatrix}$$

- 11) Let $V(F)$ be a vector space. A non-empty set $W \subseteq V$. The necessary and sufficient condition for W to be a subspace of V is $a, b \in F$ and $\alpha, \beta \in V \Rightarrow a\alpha + b\beta \in W$
- 12) Let W be a subspace of a finite dimensional vector space $V(F)$ then
- $$\dim V/W = \dim V - \dim W.$$

Part - II

- 13) Find the linear Transformation $T(x, y, z)$ where $T : \mathbb{R}^3 \rightarrow \mathbb{R}$ is defined by
- $$T(1, 1, 1) = 3, \quad T(0, 1, -2) = 1 \quad \text{and} \quad T(0, 0, 1) = -2.$$
- 14) State and prove Rank-nullity theorem
- 15) State and prove Bessel's inequality
- 16) If $(1, 0, 1, 1)$ $(-1, 0, -1, 1)$ $(0, -1, 1, 1)$ forms a basis of a subspace of $\mathbb{R}^4(\mathbb{R})$ use Gram-Schmidt process to obtain an orthonormal basis.

**ADUSUMILLI GOPALA KRISHNAIAH & SUGARCANE GROWERS' SIDDHARTHA
DEGREE COLLEGE OF ARTS & SCIENCE, VUYYURU-521165**

(An Autonomous College in the jurisdiction of Krishna University)

Re-accredited by NAAC with Grade 'A'



Minutes of the meeting of Board of Studies (Odd Semester) 2021 - 2022

DEPARTMENT OF PHYSICS

Minutes of the meeting of Board of studies in Physics for the Autonomous course of A.G. & S.G. Siddhartha Degree College of Arts & Science, Vuyyuru held at 10.30 A.M on 02 – 11 - 2021 in the Department of Physics.

Sri U. Ram Prasad Presiding

Members Present:

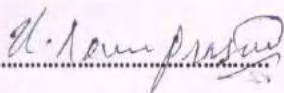
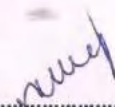
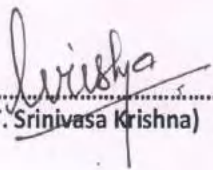
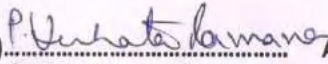
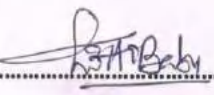
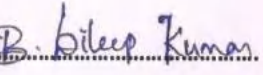
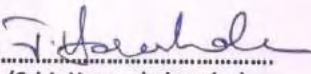
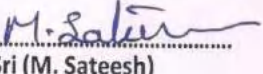
- 1)  Chairman
(Sri U. Ram Prasad) Head, Department of Physics
A.G. & S.G.S. Degree College of Arts & science, Vuyyuru - 521165
- 2)  University Nominee
(Dr. M. Rami Reddy) Registrar
Krishna University, Machilipatnam.
- 3)  Academic Council Nominee
(Dr. T. Srinivasa Krishna) Associate Professor,
H.O.D Dept. of Physics, P.B. Siddhartha college of arts & science, Vijayawada.
- 4)  Academic Council Nominee
(Sri P.V. Ramana) H.O.D Dept. of Physics,
A.J. Kalasala, Machilipatnam.
- 5)  Representative from Industry
(Sri I. Chittibabu) Sub Divisional Engineer,
BSNL, Vijayawada.
- 6)  Alumini
(Sri B. Dileep Kumar) Lecturer in Physics,
Dept. of Physics, IIIT , Nuzivid.
- 7)  Member
(Sri J. Hareeshchandra) Lecturer in Physics,
A.G. & S.G.S. Degree College of Arts & Science, Vuyyuru - 521165.
- 8)  Member
(Sri (M. Sateesh) Lecturer in Physics,
A.G. & S.G.S. Degree College of Arts & Science, Vuyyuru - 521165.

9) M.P.D. Parimala
(Smt. M.P.D. Parimala)

Member

Lecturer in Physics,

A.G. & S.G.S. Degree College
of Arts & Science,
Vuyyuru - 521165.

10) J. Dileep
(Sri J. Dileep)

Member

Lecturer in Physics,

A.G. & S.G.S. Degree College
of Arts & Science,
Vuyyuru - 521165.

Agenda for B.O.S Meeting

- 1 .To recommend the syllabi and model papers for I semester of I Degree B.Sc., Physics for the Academic year 2021-2022.
2. To recommend the syllabi and model papers for III semester of II Degree B.Sc., Physics for the Academic year 2021-2022.
3. To recommend the syllabi and model papers for V semester of III Degree B.Sc. Physics for the Academic year 2021-2022.
4. To recommend the Blue print of question papers for I, III & V semesters of B.Sc. Physics for the Academic year 2021-2022.
5. To recommend the Guidelines to be followed by the question paper setters in Physics for I, III, V Semester – end exams.
6. To recommend the teaching and evaluation methods to be followed under Autonomous Status.
7. Any suggestions regarding seminars, workshops, Guest lecture to be organized.
8. Recommend the panel of paper setters and Examiners to the controller of Examinations of Autonomous Courses of A.G. & S.G.S. Degree colleges of Arts & Science, Vuyyuru.
9. Any other matter.

Chairman.

RESOLUTIONS

- 1) It is resolved to Change the **syllabi and model papers for I semester of I B.Sc.** under Choice Based Credit System (CBCS 2020-2021 onwards) for the Academic year 2021-22.
- 2) It is resolved to change the **syllabi and model papers for III semester of II B.Sc.** under Choice Based Credit System (CBCS 2020-2021 onwards) for the Academic year 2021-22.
- 3) It is resolved to follow the same **syllabi and model papers** under Choice Based Credit System (CBCS) prescribed by Krishna University for **V semester of III B.Sc.**
- 4) It is resolved to change the **Blue print** of I and III semesters of Degree I & II B.Sc. for the Academic year 2021-22.
 - It is resolved to continue the same **Blue prints** of V semester of Degree B.Sc. for the Academic year 2021-22 also.
- 5) It is resolved to change the **Guidelines** of I and III semesters of Degree I & II B.Sc. for the Academic year 2021-22.
 - It is resolved to continue the same **Guidelines** of V semesters of Degree B.Sc. for the Academic year 2021-22.
- 6) It is resolved to continue the following teaching and evolution methods for Academic year 2021-2022.

Teaching Methods:

Besides the conventional methods of teaching, we use modern technology i.e. using of LCD projector, U boards, virtual lab etc, for better understanding of concepts.

Evaluation of a student is done by the following procedure:

➤ Internal Assessment Examinations:

- For I B.SC.(sem I) out of 100 marks in each paper, 25 marks shall be allocated for internal assessment and 75 marks shall be allotted for external valuation.
- Out of these 25 marks, **15 marks are allocated for announced tests (i.e.IA-1 & IA-2).** Two announced tests will be conducted and average of these two tests shall be deemed as the marks obtained by the student, **5 marks** are allocated on the basis of candidate's **percentage of attendance and remaining 5 marks are allocated for the assignment.**
- For II B.SC.(sem III) out of 100 marks in each paper, 30 marks shall be allocated for internal assessment and 70 marks shall be allotted for external valuation.
- For III B.Sc (**i.e. V semester**) out of 100 marks in each paper, 30 marks shall be allocated for internal assessment and 70 marks shall be allotted for external valuation.
- Out of these 30 marks, **20 marks are allocated for announced tests (i.e.IA-1 & IA-2).** Two announced tests will be conducted and average of these two tests shall be deemed as the marks obtained by the student, **5 marks** are allocated on the basis of candidate's **percentage of attendance, and 5 marks** are allocated for **assignment / class room seminars.**

➤ **Semester – End Examination:**

- The maximum marks for I B.Sc. Semester I – End examination shall be 75 marks and duration of the examination shall be 3 hours.
 - The maximum marks for II B.Sc. and III B.Sc. Semesters III and V – End examination shall be 70 marks and duration of the examination shall be 3 hours.
 - **Semester – End examinations** in theory papers and **practical Examinations** shall be conducted at the end of every semester **I, III & V for I, II & III B.Sc.**
- 7) Discussed and recommended for organizing seminars, **Guest lecturers, workshops** to upgrade the knowledge of students, for the approval of the academic council.
 - 8) Discussed and empowered the Head of the department of Physics to suggest the panel of paper setters and examiners to the controller of examinations.
 - 9) Proposed to conduct add on Programme /Certificate course.

Chairman.



A.G & S.G.SIDDHARTHA DEGREE COLLEGE OF ARTS & SCIENCE

Vuyyuru-521165.

NAAC reaccredited at 'A' level

Autonomous -ISO 9001 – 2015 Certified

Department of Physics

Title of the Paper: MECHANICS, WAVES AND OSCILLATIONS

Semester: I I B.Sc. (MPC&MPCs)

Course Code	PHY-101C	Course Delivery Method	Class Room / Blended Mode - Both
Credits	4	CIA Marks	25
No. of Lecture Hours / Week	4	Semester End Exam Marks	75
Total Number of Lecture Hours	60	Total Marks	100
Year of Introduction :2020-21	Year of Offering: 2021 - 22	Year of Revision: --- 2021-22	Percentage of Revision: 15%

Course Objectives:

1. provide an in-depth understanding of the principles of Newtonian mechanics and apply them to solve problems involving the dynamic motion of classical mechanical systems
2. explain the limitations of Newtonian mechanics for motion at very high velocities, and thus introduce the special theory of relativity
3. provide hands-on experience to perform experiments to study some properties of matter and oscillations
4. By Learning Fourier analysis, student can analyse different mechanical, optical and electro-magnetic waves
5. To attain the knowledge of Ultrasonic waves and apply to different fields.

Course outcomes:

On successful completion of this course, the students will be able to:

CO1: Remember the rotational kinematic relations and its applications such as freely rotating symmetric top. Comprehend the general characteristics of central forces and the application of Kepler's laws to describe the motion of planets and satellite in circular orbit through the study of law of Gravitation.

CO2: Understand Newton's laws of laws of motion, reference frames, and its applications i.e., projectile motion, Rocket motion, simple harmonic oscillator.

- CO3:** Apply the rotational kinematic relations, the principle and working of gyroscope and its applications and the precessional motion of a freely rotating symmetric top.
- CO4:** Analyze the features of central forces with respect to planetary motion, waves and oscillations and formulate the problem of coupled oscillations and solve them to obtain normal modes of oscillation and their frequencies in simple mechanical systems.
- CO5:** Figure out the formation of harmonics and overtones in a stretched string and acquire knowledge on Ultrasonic waves, their production and detection and their applications in different fields.
- CO6** Develop understanding of special theory of relativity and its applications to understand length contraction, time dilation, relativistic addition of velocities, conservation of momentum and variation of mass, relativistic momentum, relativistic energy, and mass energy relation.

Semester : I Paper : I Syllabus

Course Details

Unit	Learning Units	Lecture Hours
I	<p>1. Mechanics of Particles (5 hrs) Review of Newton's Laws of Motion, Motion of variable mass system, Multistage rocket, Concept of impact parameter, scattering cross-section, Rutherford scattering-Derivation.</p> <p>2. Mechanics of Rigid bodies (7 hrs) Rigid body, rotational kinematic relations, Equation of motion for a rotating body, Angular momentum and Moment of inertia tensor, Euler equations, Precession of a spinning top, Gyroscope, Precession of the equinoxes</p>	12
II	<p>Motion in a Central Force Field (12hrs)</p> <p>3. Celestial Mechanics Central force - definition and examples, characteristics of central forces, conservative nature of central forces, Equation of motion under a central force,</p> <p>4. Orbital Mechanics Kepler's laws of planetary motion- Proofs, Motion of satellites – escape velocity, orbital velocity, Basic idea of Global Positioning System (GPS),</p>	12
III	<p>5. Frames of Reference and Transformation (5 hrs) Introduction to relativity, Frames of reference - Galilean transformations, absolute frames, Michelson-Morley experiment & negative result.</p> <p>6. Consequences of Relativistic Transformations (7 hrs) Postulates of Special theory of relativity, Lorentz transformation, time dilation, length contraction, variation of mass with velocity, Einstein's mass-energy relation</p>	12
IV	<p>7. Undamped, Damped and Forced oscillations: (07 hrs) Simple harmonic oscillator, Damped harmonic oscillator, Forced harmonic oscillator –differential equations and solutions, Resonance, Logarithmic decrement, Relaxation time and Quality factor.</p> <p>8. Fourier analysis (05 hrs) Fourier theorem (Statement & limitations), evaluation of the Fourier coefficients using Fourier's theorem, analysis of periodic wave functions - square wave, triangular wave.</p>	12
V	<p>9. Vibrating Strings: (07 hrs) Transverse wave propagation along a stretched string, General solution of wave equation and its significance, Modes of</p>	12

	vibration of stretched string clamped at ends, Overtones and Harmonics. 10. Ultrasonics: (05 hrs) Ultrasonics, General Properties of ultrasonic waves, Production of ultrasonics by piezoelectric and magnetostriction methods, Detection of ultrasonics, Applications of ultrasonic waves, SONAR	
--	--	--

LIBRARY ACTIVITY

Student visit library to refer and gather information regarding seminar topics and assignments.

TEXT BOOKS

1. B. Sc. Physics, Vol.1, Telugu Academy, Hyderabad
2. Unified Physics - Waves and Oscillations, Jai PrakashNath & Co.Ltd.

REFERENCE BOOKS:

1. Fundamentals of Physics Vol. I - Resnick, Halliday, Krane, Wiley
2. College Physics-I. T. Bhimasankaram and G. Prasad. Himalaya Publishing House.
3. University Physics-FW Sears, MW Zemansky & HD Young, Narosa Publications, Delhi
4. Mechanics, S.G. Venkatachalapathy, Margham Publication, 2003.
5. Waves and Oscillations. N. Subramanyam and Brijlal, VikasPulications.
6. Waves & Oscillations. S. Badami, V. Balasubramanian and K.R. Reddy, Orient Longman.
7. The Physics of Waves and Oscillations, N.K. Bajaj, Tata McGraw Hill
8. Science and Technology of Ultrasonics- Baldevraj, Narosa, New Delhi,2004

STUDENT ACTIVITY

1. Seminars
2. Assignments.

LIBRARY ACTIVITY

Student visit library to refer and gather information regarding seminar topics and assignments.

Course Delivery method: Face-to-face / Blended

Course has focus on: Foundation & Employability

Course Code	PHY-101P	Course Delivery Method	Class Room
Credits	1	CIA Marks	10
No. of Lecture Hours / Week	2	Semester End Exam Marks	40
Total Number of Lecture Hours	30	Total Marks	50
Year of Introduction :2020-21	Year of Offering: 2021 - 22	Year of Revision: --- 2021-22	Percentage of Revision: 0%

Practical Course 1: Mechanics, Waves and Oscillations

Semester: I **I B.Sc. (MPC&MPCs)**
Work load: 30 hrs 2 hrs/week **Credits:01**

Course outcomes (Practicals):

On successful completion of this practical course, the student will be able to:

- CO 1.** Perform experiments on Properties of matter such as the determination of moduli of elasticity viz., Young's modulus, Rigidity modulus of certain materials; Surface tension of water, Coefficient of viscosity of a liquid, Moment of inertia of some regular bodies by different methods and compare the experimental values with the standard values.
- CO 2.** Know how to determine the acceleration due to gravity at a place using Compound pendulum and Simple pendulum.
- CO 3.** Notice the difference between flat resonance and sharp resonance in case of volume resonator and sonometer experiments respectively.
- CO 4.** Verify the laws of transverse vibrations in a stretched string using sonometer and comment on the relation between frequency, length and tension of a stretched string under vibration.
- CO 5.** Demonstrate the formation of stationary waves on a string in Melde's string experiment.
- CO 6.** Observe the motion of coupled oscillators and normal modes.

EXPERIMENTS LIST:

1. Young's modulus of the material of a bar (scale) by uniform bending
2. Young's modulus of the material a bar (scale) by non- uniform bending
3. Surface tension of a liquid by capillary rise method
4. Simple pendulum- normal distribution of errors-estimation of time period and the error of the mean by statistical analysis

5. Determination of 'g' by compound/bar pendulum
6. Verification of laws of vibrations of stretched string –Sonometer
7. Bifilar suspension –Moment of inertia of a regular rectangular body.
8. Rigidity modulus of material of a wire-Dynamic method (Torsional pendulum)
9. Volume resonator experiment
10. Viscosity of liquid by the flow method (Poiseuille's method)
11. Determination of the force constant of a spring by static and dynamic method.
Coupled oscillators
12. Determination of frequency of a bar –Melde's experiment.

Note :

1. 9 (NINE) experiments are to be done and recorded in the lab. These experiments will be evaluated in CIA.
2. For certification minimum of 7 (Seven) experiments must be done and recorded by student who had put in 75 % of attendance in the lab.
3. **Best 6 experiments are to be considered for CIA.**
4. 10 marks for CIA.
5. 40 marks for practical exam.

The marks distribution for the Semester End practical examination is as follows:

Formula/ Principle / Statement with explanation of symbols	05
Diagram/Circuit Diagram / Tabular Columns	05
Setting up of the experiment and taking readings/Observations	10
Calculations (explicitly shown) + Graph + Result with Units	05
Procedure and precautions	05
Viva-voce	05
Record	05
Total Marks:	40

Model Question Paper
Mechanics, Waves and Oscillations
I B.Sc. (MPC&MPCs)
Semester End Exam Marks; 75
SECTION-A

Semester: I

Answer the following:

5 x 10 = 50 M

- 1 A) What is Rutherford scattering? Obtain an expression for number of particles scattered per unit area. (CO1).

(OR)

B) What is precessional motion? Find angular velocity of precession of a spinning top. Show that the rate of precession is independent of mass but depends on the distribution of mass. (CO2).

2. A) What is conservative force? Show that central forces are conservative. (CO2).

(OR)

B) State Kepler's third law of motion. And prove that the square of period of revolution of a planet moving in a circular orbit round the sun is proportional to the cube of its distance from the sun. (CO2)

- 3 A) State the fundamental postulates of special theory of relativity and deduce the Lorentz transformations. (CO3)

(OR)

B) Describe the Michelson-Morley experiment and explain the physical significance of negative results. (CO3)

- 4 A) What are damped oscillations? Derive the differential equation of damped Harmonic oscillator and discuss the case of under damping. (CO3).

(OR)

B) State Fourier Theorem and evaluate Fourier coefficients. (CO4).

- 5 A) What are transverse waves? Obtain the equation of velocity of transverse wave in a wire kept under tension. (CO5).

(OR)

B) What are ultrasonics? Describe Magnetostriction method of producing ultrasonics (CO5).

SECTION-B

Answer any **THREE** of the following questions:

3x5=15M

6. State Newton's laws of motion and give two examples each. (CO1)
7. Explain central forces with examples. (CO2)
8. Explain time dilation. (CO3)
9. What is logarithmic decrement and relaxation time? (CO4)
10. Explain overtones and harmonics. (CO5)

Section – C

2X5=10M

Answer any **TWO** of the following:

11. The kinetic energy of metal disc rotating at a constant speed of 5 revolutions per second is joules. Find the angular momentum of the disc. (CO2)
12. If the Earth be one-half of its present distance from the sun, what will be the number of days in a year (CO2)
13. If the energy note of frequency 100Hz decreases to one half of its original value in one second, calculate the Q-factor, (CO4)
14. A piezoelectric crystal has a thickness of 0.002m. If the velocity of sound wave in crystal is 5750m/s, calculate the fundamental frequency of crystal. (CO5)



A.G & S.G.SIDDHARTHA DEGREE COLLEGE OF ARTS & SCIENCE

Vuyyuru-521165.

NAAC reaccredited at 'A' level

Autonomous -ISO 9001 – 2015 Certified

Department of Physics

Title of the Paper: *THERMODYNAMICS AND RADIATION PHYSICS*

Semester: III II B.Sc. (MPC&MPCs)

Course Code	PHY-301C	Course Delivery Method	Class Room / Blended Mode - Both
Credits	4	CIA Marks	30
No. of Lecture Hours / Week	4	Semester End Exam Marks	70
Total Number of Lecture Hours	60	Total Marks	100
Year of Introduction :2020-21	Year of Offering: 2021 - 22	Year of Revision: --- 2021-22	Percentage of Revision: 15%

Course Description:

The course makes the students able to understand the basic physics of heat and temperature and their relation with energy, work, radiation and matter. The students also learn how laws of thermodynamics are used in a heat engine to transform heat into work. The course contains the study of laws of thermodynamics, thermodynamic description of systems, thermodynamic potentials, kinetic theory of gases.

Course Objectives:

1. Introduce the microscopic approach through kinetic theory of gases and basic statistical thermodynamics
2. Give the fundamentals of thermodynamic systems, the laws of thermodynamics and their application to thermodynamic problems
3. Provide essential tools to analyze Carnot engine, heat engines and refrigerators with the help of their thermodynamic cycles
4. Highlight the use of mathematical methods to derive thermodynamic relationships
5. Analyses thermal conductivity and black body radiation

COURSE OUTCOMES

Upon successful completion of this course, students should have the knowledge and skills to:

- CO1 State the First Law and define heat, work, thermal efficiency and the difference between various forms of energy and describe energy exchange processes, reversible and irreversible process.
- CO2 Understand the microscopic behavior of molecules, interactions and the concepts of transport phenomena of heat transfer, mass transfer and momentum transfer.
- CO3 use kinetic theory of gases to derive expressions for pressure of an ideal gas, heat capacities of solids and gases and transport properties
- CO4 Understand very low temperatures like the concept of Joule Thomson effect, Liquefaction of gases and the properties at very low temperatures.
- CO5 Ability to evaluate entropy changes in a wide range of processes and determine the reversibility or irreversibility of a process from such calculations. Examine the nature of black body radiations and the basic theories.
- CO6 Develop critical understanding of concept of Thermodynamic potentials, the formulation of Maxwell's equations and its applications.

Semester : III Paper : III Syllabus

Course Details

Unit	Learning Units	Lecture Hours
I	<p>Kinetic Theory of gases:</p> <p>1. Kinetic Theory of gases - Introduction, Maxwell's law of distribution of molecular velocities (qualitative treatment only), Mean free path, Degrees of freedom, Principle of equipartition of energy (Qualitative ideas only).</p> <p>2. Transport phenomenon in ideal gases: viscosity, Thermal conductivity and diffusion of gases.</p>	12
II	<p>3. Introduction to Thermodynamics: Introduction- Isothermal and Adiabatic processes, work done in this processes, Reversible and irreversible processes, Heat Engines- Carnot's engine and its efficiency, Carnot's theorem, Thermodynamic scale of temperature and its identity with perfect gas scale, Second law of thermodynamics.</p> <p>4. Entropy Entropy, Physical significance, Change in entropy in reversible and irreversible processes; Entropy and disorder-Entropy of Universe; Temperature-Entropy (T-S) diagram and its uses - change of entropy when ice changes into steam (Qualitative).</p>	12
III	<p>Thermodynamic Potentials and Maxwell's equations:</p> <p>((NO PROBLEM)</p> <p>5. Thermodynamic potentials</p> <p>Thermodynamic potentials-Internal Energy, Enthalpy, Helmholtz Free Energy, Gibb's Free Energy and their significance, Derivation of Maxwell's thermodynamic relations from thermodynamic potentials,</p> <p>6. Applications of Maxwell's Thermodynamic Relations</p> <p>(i) Clausius-Clayperon's equation (ii) Value of $C_P - C_V$ (iii) Value of C_P/C_V (iv) Joule-Kelvin coefficient for ideal and Van der Waals' gases</p>	12
IV	<p>Low temperature Physics:</p> <p>7. Methods for producing very low temperatures</p>	12

	Joule Kelvin effect, Porous plug experiment, Joule expansion, Distinction between adiabatic and Joule Thomson expansion, Expression for Joule Thomson cooling, 8. Production of low temperature Adiabatic demagnetization (Derivation), Principle of Refrigeration, effects of chloro and fluoro carbons on ozone layer.	
V	Quantum theory of radiation: 9. Radiation Laws (7 hrs) Blackbody and its spectral energy distribution of black body radiation, Kirchoff's law, Wein's displacement law, Stefan-Boltzmann's law and Rayleigh-Jean's law (No derivations), Planck's law of black body radiation-Derivation, Deduction of Wein's law and Rayleigh- Jean's law from Planck's law. 10. Measurement of Radiation (5hrs) Pyrometers, Angstrom pyro-heliometer, Solar constant and its determination. Estimation of surface temperature of Sun.	12

TEXT BOOKS

1. BSc Physics, Vol.2, Telugu Akademy, Hyderabad
2. Unified Physics Vol.2, Optics & Thermodynamics, Jai Prakash Nath &Co.Ltd., Meerut

REFERENCE BOOKS:

1. Thermodynamics, R.C. Srivastava, S.K. Saha & Abhay K. Jain, Eastern Economy Edition.
2. Fundamentals of Physics. Halliday/Resnick/Walker.C. Wiley India Edition 2007
3. Heat, Thermodynamics and Statistical Physics-N Brij Lal, P Subrahmanyam, P S Hemne, S. Chand& Co., 2012
4. Heat and Thermodynamics- MS Yadav, Anmol Publications Pvt. Ltd, 2000
5. University Physics, HD Young, MW Zemanski Sears, Narosa Publishers, New Delhi

STUDENT ACTIVITY

1. Seminars
2. Assignments.

LIBRARY ACTIVITY

Student visit library to refer and gather information regarding seminar topics and assignments.

Course Delivery method: Face-to-face / Blended

Course has focus on: Foundation & Employability

Practical Course 3: Thermodynamics and Radiation Physics Lab

Course Code	PHY-301P	Course Delivery Method	Class Room
Credits	1	CIA Marks	10
No. of Lecture Hours / Week	2	Semester End Exam Marks	40
Total Number of Lecture Hours	30	Total Marks	50
Year of Introduction :2020-21	Year of Offering: 2021 - 22	Year of Revision: --- 2021-22	Percentage of Revision: 0%

Semester: III

II B.Sc. (MPC&MPCs)

Work load: 30 hrs

2 hrs/week

Credits:01

Work load: 30hrs

2 hrs/week

Credits: 01

Objectives:

- * The primary objective of this course is to provide the fundamental knowledge to understand the behaviour of thermal systems.
- * This course provides a detailed necessary transfer through solids, fluids, and experimental analysis, including the application and heat vacuum.
- * Convection, conduction, and radiation heat transfer in one and two dimensional steady and unsteady systems are examined.

COURSE OUTCOMES

Upon successful completion of this course, students should have the knowledge and skills to:

- CO1: Determine the thermal conductivity of bad conductor-Lee's method, thermal conductivity of rubber and Coefficient of thermal conductivity of copper by using Searle's apparatus.
- CO2: Study the heating efficiency of electrical kettle with varying voltages.
- CO3: Determine Specific heat of a liquid by Joule's calorimeter and study Barton's radiation correction by plotting a graph between temperature and time and Specific heat of a liquid by applying Newton's law of cooling correction.
- CO4: Study temperature variation of resistance in a thermostat.
- CO5: Study the heating efficiency of electrical kettle with varying voltages.

List of experiments

1. Study of variation of resistance with temperature - Thermistor.
2. Thermal conductivity of bad conductor-Lee's method
3. Thermal conductivity of rubber.
4. Measurement of Stefan's constant - emissive method
5. Heating efficiency of electrical kettle with varying voltages.
6. Specific heat of a liquid –Joule's calorimeter –Barton's radiation correction
7. Specific heat of a liquid by applying Newton's law of cooling correction.
8. Thermo emf- thermo couple - Potentiometer
9. Thermal behavior of an electric bulb (filament/torch light bulb)
10. Measurement of Stefan's constant

Note :

1. 9 (NINE) experiments are to be done and recorded in the lab. These experiments will be evaluated in CIA.
2. For certification minimum of 7 (Seven) experiments must be done and recorded by student who had put in 75 % of attendance in the lab.
3. **Best 6 experiments are to be considered for CIA.**
4. 10 marks for CIA.
5. 40 marks for practical exam.

The marks distribution for the Semester End practical examination is as follows:

Formula/ Principle / Statement with explanation of symbols	05
Diagram/Circuit Diagram / Tabular Columns	05
Setting up of the experiment and taking readings/Observations	10
Calculations (explicitly shown) + Graph + Result with Units	05
Procedure and precautions	05
Viva-voce	05
Record	05
Total Marks:	40

The Guidelines to be followed by the question paper setters in Physics for the III Semester - end exams

PAPER TITLE: Thermodynamics and Radiation Physics

Paper- III Semester – III Maximum marks: 70 marks

Duration: 3Hours

Weightage for the question paper

Syllabus	Section-A (Short answer questions)	Section-B (essay questions)
Unit-1(20 Marks)	T+P	1
Unit-2(30 Marks)	T+P	2
Unit-3(15Marks)	T	1
Unit-4(25 Marks)	T	2
Unit-5(30 Marks)	T+P	2

Note: **T** means one theory question, **P** means one problem

- **Section-A** contains **5** short questions and **3** problems out of these **8** questions, the student has to answer any **4**, each question carries **5** marks.
- **Section –B** contains **8** essay questions, the student has to answer any **5** questions, each question carries **10** marks.
- The Question papers setters are requested to cover all the topics in the syllabus as per the weightage given by us.

Model Question Paper
Title of the Paper: Thermodynamics and Radiation Physics
Section-A

Answer any **FOUR** of the following:

4X5=20M

1. Write a note mean free path. (CO1)
2. Explain the second law of thermodynamics in terms of entropy. (CO2)
3. Prove $C_p - C_v = R$ (CO3)
4. Explain the effects of chloro and fluoro carbons on ozone layer. (CO4)
5. Estimate the temperature of sun. (CO5)
6. Find the R.M.S velocity of hydrogen at N.T.P and at C° ? (CO1)
7. Calculate the efficiency of a reversible engine that operates between the temperatures 200°C and 120°C ? (CO1)
8. Find the wavelength at which maximum energy is radiated by a black at a temperature of 227°C and wien's constant is $2.877 \times 10^{-3} \text{mk}$. (CO1)

Section-B

Answer any **FIVE** of the following:

5X10=50M

9. Derive an expression for Maxwell's law of distribution of molecular speeds in a gas. (CO1)
10. Describe the working of Carnot's reversible engine and derive an expression for its efficiency. (CO2)
11. What are reversible and irreversible processes? How does the entropy change in each of these processes? (CO2)
12. Define the four thermodynamic potentials. Obtain Maxwell's thermodynamic equations using these potentials. (CO3)
13. What is adiabatic demagnetization? How is this principle used in producing low temperatures? (CO4)
14. Explain Joule-kelvin effect. Derive an expression for Joule-Thompson cooling. (CO4,)
15. Derive the Planck's formula for the distribution of energy in black body radiation. (CO5)
16. Describe the construction and working of Angstrom pyroheliometer (CO5)



A.G & S.G.SIDDHARTHA DEGREE COLLEGE OF ARTS & SCIENCE

Vuyyuru-521165.

NAAC reaccredited at 'A' level

Autonomous -ISO 9001 – 2015 Certified

Department of Physics

Title of the Paper: Electricity, Magnetism and Electronics

Semester: V III B.Sc. (MPC&MPCs)

Course Code	PHY-501C	Course Delivery Method	Class Room / Blended Mode - Both
Credits	4	CIA Marks	30
No. of Lecture Hours / Week	4	Semester End Exam Marks	70
Total Number of Lecture Hours	60	Total Marks	100
Year of Introduction :2019-2020	Year of Offering: 2021 - 22	Year of Revision: --- 2021-22	Percentage of Revision: 15%

Course Description:

The study of electromagnetic theory provides basic foundation for the students to understand advanced courses of physics. This course is helpful for the students seeking job opportunities in government, corporate and private sectors. It is also helpful for the students to find opportunities research & development (R & D). The course involves the study of electromagnetic theory, Maxwell's equations and electromagnetic waves. The in depth understanding of electronics at post graduate level opens scope for the students to work in private and public sector enterprises.

Course Objective:

1. Understand the magnetic effects of electric current.
2. Study the unification of electric and magnetic phenomena.
3. To gain knowledge about Maxwell's equations and EM waves
4. develop competence in using laboratory instruments to carry out experiments to study different electromagnetic phenomena, that will enhance students class room learning

Course outcomes:

On successful completion of this course, the students will be able to:

- CO1 Remember and recollect of basic electrodynamic definitions and apply in daily life.
- CO2 Understanding of electrodynamics and relativity.
- CO3 Ability to define and derive expressions for the energy both for the electrostatic and magnetostatic fields, and derive Poyntings theorem from Maxwell's equations and physical interpret.
- CO4 Analyze Maxwell's equation in different forms (differential and integral) and apply them to diverse engineering problems.
- CO5 Evaluate and perform basic experiments to investigate the behavior of electric and magnetic fields for different configurations.
- CO6 Create new circuits and formulate by learning ac circuits.

Semester : V Paper V Syllabus

Course Details

Unit	Learning Units	Lecture Hours
I	<p>1.Electrostatics Gauss's law Statement and its proof-Electric field intensity due to (1) Uniformly charged sphere and (2) an infinite conducting sheet of charge. Electric potential- Equipotential surface –potential due to i) a point charge ii) charged spherical shell .</p> <p>2.Dielectrics: Electric dipolement and molecular polarizability- Electric displacement D, electric polarization P – relation between D, E, and P- Dielectric constant, susceptibility.</p>	12
II	<p>3. Electric and magnetic field Biot – Savart's law and calculation of B due to long straight wire, a circular current loop and solenoid. Hall effect-determination of Hall coefficient and applications.</p> <p>4.Electromagnetic-induction Faraday's law – Lenz's law self and mutual inductance, coefficient of coupling, calculation of self inductance of a long solenoid, energy stored in magnetic field. Transformer- energy losses and efficiency.</p>	12
III	<p>5.Alternating current and electro magnetic waves Alternating current –Relation between current and voltage in LR and CR circuits, vector diagrams, LCR series and parallel resonant circuit , Q- factor, power in AC circuits.</p> <p>6.Maxwell's equations Idea of displacement current- Maxwell's equations (integral and differential forms) (no derivation) Maxwell's wave equation(with derivation), Transverse nature of electromagnetic wave. Pointing Vector (statement and proof) production of electromagnetic wave Hertz experiment.</p>	12
IV	<p>7.Basic electronics: PN junction diode Zener diode ,I-V characteristics, PNP and NPN Transistors, CB,CE and CC configuration Relation between α β and Γ transistors (CE) characteristics, Transistor as an amplifier</p>	12
V	<p>Digital electronics: Number systems-conversion of binary to decimal system and vice versa. Binary addition and subtraction (1's and 2's complement methods) laws of Boolean algebra-De Morgan's laws- statement and proof basic logic gates, NAND and NOR as universal gates Half adder and FULL adder.</p>	12

REFERENCE BOOKS

- 1) BSC Physics vol.3 Telugu Akademy, Hyderabad.
- 2) Electricity, Magnetism D,N Vasudeva. S.chand & co.,
- 3) Electricity, Magnetism and Electronics, K.K.Tewai, R.Chand &co.,
- 4) Principles of electronics, V.K.Mehta, S.Chand &co.,
- 5) Digital principles and applications A.P Malvino and D.P.Leach, Mc GrawHILL Edition.

The Guidelines to be followed by the question paper setters in Physics for the V Semester - end exams

PAPER TITLE: Electricity, Magnetism and Electronics

Paper- V Semester – V Maximum marks: 70 marks Duration: 3Hours

Weightage for the question paper

Syllabus	Section-A (Short answer questions)	Section-B (essay questions)
Unit-1 (25 Marks)	T	2
Unit-2 (20 Marks)	T+P	1
Unit-3 (30Marks)	T+P	2
Unit-4 (20 Marks)	T+T	1
Unit-5 (25 Marks)	T	2

Note: **T** means one theory question, **P** means one problem

- **Section-A** contains **6** short questions and **2** problems out of these **8** questions, the student has to answer any **4**, each question carries **5** marks.
- **Section –B** contains **8** essay questions, the student has to answer any **5** questions, each question carries **10** marks.
- The Question papers setters are requested to cover all the topics in the syllabus as per the weightage given by us.

SEMESTER – V	COURSE CODE : PHY- 501 C
PAPER TITLE : Electricity, Magnetism and Electronics	

Duration : 3Hours

Maximum marks : 70

Pass marks : 28 marks

MODEL PAPER

III B.Sc. (PHYSICS)- V SEMESTER
ELECTRICITY, MAGNETISM AND ELECTRONICS

TIME: 3 Hrs

PHY – 501 C

MAX MARKS: 70

PASS MARK : 28

.....
SECTION – A

ANSWER ANY FOUR OF THE FOLLOWING

(4 X 5 = 20 M)

- 1) Write a short note on equi - potential surfaces
- 2) obtain an expression for energy stored in a magnetic field
- 3) Derive expression for power in ac circuit
- 4) Explain CE configuration of a transistor
- 5) Explain briefly how a transistor works as an amplifier
- 6) Explain about half adder circuit with truth table.
- 7) Calculate the intensity of the magnetic field at the center of a circular coil of radius 20 cm and 40 turns having a current of 2A in it.
- 8) In a series RLC circuit $R = 100 \text{ ohm}$, $L = 0.5\text{H}$ and $C = 0.4 \mu\text{F}$. calculate resonant frequency

SECTION – B

ANSWER ANY FIVE OF THE FOLLOWING QUESTIONS (5 X 10 = 50 M)

- 9) Derive an expression for the electric field due to uniformly charged sphere using Gauss law?
- 10) Define D, E and P derive the relation between them
- 11) Calculate the magnetic induction due to a long straight wire using Biot-savart's law
- 12) State and prove pointing theorem
- 13) Explain the growth and decay of charge in LR- circuit
- 14) Describe the construction and working of Zener diode.
- 15) State and prove De Morgan's theorem with examples.
- 16) Explain about basic logic gates with truth tables.

PHYSICS	PHY-P501	2021-22	B.Sc. (MPC&MPCs)
----------------	-----------------	----------------	-----------------------------

Practical paper V: Electricity, Magnetism and Electronics

Exam duration : 3Hours

Maximum marks : 50 marks

Work load:30hrs

Credits : 1

Minimum of 6 experiments to be done and recorded

1. Figure of merit of a moving coil galvanometer.
2. LCR circuit series/parallel resonance, Q-factor
3. Determination of Ac-frequency-sonometer
4. Verification of Kirchoff's laws
5. Field along the axis of a circular coil carrying current.
6. PN Junction diode Characteristics
7. characteristics of Zener diode
8. Transistor CE Characteristics.
9. Logic Gates –OR ,AND, NOT,and NAND gates verification of truth tables.
10. Verification of De Morgan's theorems.



A.G & S.G.SIDDHARTHA DEGREE COLLEGE OF ARTS & SCIENCE

Vuyyuru-521165.

NAAC reaccredited at 'A' level

Autonomous -ISO 9001 – 2015 Certified

Department of Physics

Title of the Paper: Modern Physics

Semester: V

III B.Sc. (MPC&MPCs)

Course Code	PHY-502 C	Course Delivery Method	Class Room / Blended Mode - Both
Credits	4	CIA Marks	30
No. of Lecture Hours / Week	4	Semester End Exam Marks	70
Total Number of Lecture Hours	60	Total Marks	100
Year of Introduction :2019-2020	Year of Offering: 2021 - 22	Year of Revision: --- 2021-22	Percentage of Revision: 10%

Course Description:

Students would know about the basic principles in the development of modern physics. The topics covered in the course build a basic foundation of undergraduate physics students to study the advance branches: quantum physics, nuclear physics and particle physics. The course contains the study of atomic models, spectroscopy, matter waves, Schrodinger wave equations, brief idea of nuclear physics, and superconductivity. The students have the opportunity to use the basic principles of condensed matter physics in frontier areas of research and development in the field of material science, nanoscience and nanotechnology.

Course Objectives:

1. To learn the concepts in Atomic Physics.
2. Review the experiments that led development of quantum theory
3. Understand the underlying foundations and basic principles of quantum mechanics
4. impart knowledge of the nuclear processes that yield nuclear energy
5. Acquire the knowledge of Nano materials

Course outcomes:

On successful completion of this course, the students will be able to:

- CO1 Remember the different atomic models and basic knowledge of spectroscopy
- CO2 Understand the theory and application of microwave, infrared and Raman spectroscopy
- CO3 Apply non-relativistic Schrödinger wave mechanics to a variety of potentials in one and three dimensions.
- CO4 Analyse the prerequisite in a molecule towards its Rotational and vibrational activity
- CO5 Gain knowledge on classification of nano materials and understand the basics of nano technology and its various applications and Superconductivity and their practical applications.
- CO6 Examine the basic properties of nuclei, characteristics of Nuclear forces, salient features of particle physics.

Semester: V Paper : VI Syllabus

Course Details

Unit	Learning Units	Lecture Hours
I	<p>1. Atomic and molecular physics</p> <p>Introduction – Drawbacks of Bohr’s atomic model – Sommerfeld’s elliptical orbits- relativistic correction (no derivation). Vector atom model and Stern & Gerlach experiment - quantum numbers associated with it. L-S and j-j coupling schemes. Zeeman Effect and its experimental study.</p> <p>Raman effect, stokes and Anti stokes lines . Quantum theory of Raman effect. Experimental arrangement – Applications of Raman effect.</p>	12
II	<p>2. Matter waves & Uncertainty Principle</p> <p>Matter waves, de Broglie’s hypothesis – wavelength of matter waves, Properties of matter waves – Davisson and Germer experiment, uses of electron diffraction-Phase velocity and Group velocity (definitions only)- relation between phase velocity and Group velocity–Heisenberg’s uncertainty principle for position and momentum (x and p) & energy and time (E and t). Experiment verification.</p>	12
III	<p>3. Quantum (wave) mechanics</p> <p>Basic postulates of quantum mechanics – Schrodinger time independent and time dependent wave equation – derivations. Physical interpretation of wave function. Applications of Schrodinger wave equation to particle in one dimensional infinite box. Harmonic oscillator.</p>	12
IV	<p>4. General properties of Nuclei</p> <p>Basic ideas of nucleus – size, mass, charge density (matter energy), binding energy, angular momentum, parity, magnetic moment, electric quadrupole moments. Liquid drop model and shell model (qualitative aspects only)- Magic numbers.</p> <p>5. Radioactivity decay</p> <p>Alpha decay : basis of α – decay processes. Range of α-particles , Geiger’s Law, Geiger- Nuttal law. β – decay, β ray continuous and discrete spectrum, neutrino hypothesis.</p>	12
V	<p>6. Crystal structure</p> <p>Amorphous and crystalline materials, unit cell, Miller indices, reciprocal lattice, types of lattices, diffraction of X- rays</p>	12

	<p>by crystals, Bragg's law, experimental techniques, Laue's method and powder diffraction method.</p> <p>7. Superconductivity:</p> <p>Introduction – experimental facts, critical temperature – critical field – Meissner effect – isotope effect – Type I and Type II superconductors – BCS theory (elementary ideas only) – applications of superconductors.</p>	
--	--	--

REFERENCE BOOKS :

1. B.Sc physics, VOL .4, Telugu academy , Hyderabad.
2. Molecular structure and spectroscopy by G.Aruldas. prentice Hall of india , New Delhi.
3. Modern physics by R.Murugesan and Kiruthiga siva prasanth. S. Chand & co.
4. Modern physics by G.Aruldas & p. Rajagopal. Eastren economy edition.
5. Concepts of Modern physics by Arthur Beiser. Tata McGrew – Hill Edition.
6. Quantum Mechanics, Mahesh c Jain , Eastern Economy EDITION
7. Nuclear Physics ,Irving Kaplan, Narosa Publishing House.
8. Nuclear physics , D.C Tayal, Himalaya publishing house.
9. Elements of solid state physics, J.P srivastava, Prentice Hall of india pvt. Ltd.
10. Solid state physics, A.J.Dekkar, McMillan India.

The Guidelines to be followed by the question paper setters in Physics for the V Semester - end exams

PAPER TITLE: Modern Physics

Paper- VI Semester – V Maximum marks: 70 marks Duration: 3Hours
Weightage for the question paper

Syllabus	Section-A (Short answer questions)	Section-B (Essay questions)
Unit-1 (25 Marks)	T	2
Unit-2 (20 Marks)	T+P	1
Unit-3 (25Marks)	T	2
Unit-4 (20 Marks)	T+T	1
Unit-5 (30 Marks)	T+P	2

Note: **T** means one theory question, **P** means one problem

- **Section-A** contains **6** short questions and **2** problems out of these **8** questions, the student has to answer any **4**, each question carries **5** marks.
- **Section – B** contains **8** essay questions; the student has to answer any 5 questions. Each question carries **10** marks.

The Question papers setters are requested to cover all the topics in the syllabus as per the weightage given by us.

SEMESTER – V	COURSE CODE : PHY-502C
PAPER TITLE : Modern Physics (<u>Model Paper</u>)	

Duration : 3Hours

Maximum marks : 70

Pass marks : 28 marks

III B.Sc. Physics – V Semester – Paper –VI (2021 – 2022)

Modern Physics

Paper Code : PHY 502C

SECTION-A

Answer any FOUR questions

(4x5=20M)

1. Write the Draw backs of Bohr’s atomic model.
2. Explain deBroglie concept of matter waves.
3. Explain Geiger-Nuttal law.
4. Write a note on liquid drop model.
5. Explain Meissner effect in super conductivity.
6. State postulates of Quantum Mechanics.
7. In a crystal lattice plane cuts intercepts $2a$, $3b$ and $6c$ along the three axes where a, b and c are primitive vectors of the unit cell. Determine the miller indices of the given plane.
8. If the uncertainty in position of an electron is $4 \times 10^{-10} \text{m}$ and uncertainty in its momentum is $1.65 \times 10^{-24} \text{kg m/sec}$.

SECTION-B

Answer any FIVE questions :

(5x10=50M)

9. Describe Stern and Gerlach experiment and discuss the importance of the results obtained
10. What is Raman Effect? Write the Experimental setup to study Raman Effect.
11. Describe Davisson and Germer Experiment on electron diffraction. Discuss the results of the Experiment.
12. Derive Time independent Schrodinger wave equation.
13. Calculate the energy of a particle in one dimensional box using Schrodinger equation.
14. Mention the Basic Properties of Nucleus with reference to Size, Charge, Mass, Nuclear spin and Electric Quadra pole Moment.
15. Describe X-Ray diffraction by Laue’s method.
16. Explain Type-I and Type-II Superconductors.

PHYSICS	PHY-P502	2021-22	B.Sc. (MPC&MPCs)
----------------	-----------------	----------------	-----------------------------

Practical Paper VI : Modern Physics

Exam duration : 3Hours Maximum marks : 50 marks

Work load : 30 hrs Credits : 1

Minimum of 6 experiments to be done and recorded

1. e/m of an electron by Thomson method.
2. Determination of Planck's Constant (photocell)
3. Verification of inverse square law of light using photovoltaic cell.
4. Study of absorption of α – rays.
5. Study of absorption of β – rays.
6. Determination of range of β – particles.
7. Determination of M & H.
8. Analysis of powder X- ray diffraction pattern to determine properties of crystals.
9. Energy gap of semiconductor using junction diode.
10. Energy gap of a semiconductor using Thermistor.

Department of Chemistry
BOS Academic year 2021-22
Semester 1, 3, & 5

Minutes of the Meeting of Board of Studies in Chemistry for the Autonomous Course
A.G. & S.G. Siddhartha Degree College of Arts & Science, Vuyyuru Held at 11.00 A.M on 03-11-2021 in
the Department of Chemistry.

K.RAMESH Presiding

Members Present:

- 1) *K. Ramesh* Chairman HOD, Dept. of Chemistry,
(Sri. K.RAMESH) A.G. & S.G.S.Degree College,Vuyyuru.
- 2) *D.R. Ramasekhara Reddy* University Nominee Assistant Professor,
(Prof.D.Ramasekhara Reddy) Dept. of Chemistry,Krishna University, MTM.
- 3) *S. Kalpana* Academic Council Nominee HOD, Dept. of Chemistry,
(Dr. S. Kalpana) SDMS M College, Vijayawada.
- 4) *A. Indira* Academic Council Nominee Lecturer in Chemistry,
(Smt. A. Indira) G.D.C, Dumpagadapa
- 5) *G. Raja* Industrialist Manager, Q.A, Biophore india
(Dr. G Raja) Pharmaceuticals pvt ltd Hyd,
- 6) *M. Sowjanya* Student Nominee Lecturer in Chemistry,
(Smt. M. Sowjanya) ANR College Gudivada.
- 7) *Dr. G. Giri Prasad* Member Lecturer in Chemistry,
(Dr. G.Giri prasad) A.G. & S.G.S.Degree College,Vuyyuru
- 8) *M. Venkatasanthi* Member Lecturer in Chemistry,
(Smt. M.V.Santhi) A.G. & S.G.S.Degree College,Vuyyuru.
- 9) *P. Suresh* Member Lecturer in Chemistry,
(Sri. P.Suresh) A.G.& S.G.S.Degree College, Vuyyuru.
- 10) *M. Santhi* Member Lecturer in Chemistry,
(MS. M.Santhi) A.G.& S.G.S.Degree College,Vuyyuru.
- 11) *J. Nageswara Rao* Member Rtd.Lecturer in Chemistry,
(Sri. J.Nageswara Rao) A.G. & S.G.S.Degree College,Vuyyuru.

Agenda for B.O.S Meeting

1. To recommend the syllabus and model paper for I semester of I Degree B.Sc., Chemistry for the Academic year 2021-2022.
2. To recommend the syllabus and model papers for III semester of II Degree B.Sc., Chemistry for the Academic year 2021-2022.
3. To recommend the syllabus and model papers for V semester of III Degree B.Sc. Chemistry for the Academic year 2021-2022.
4. To recommend the Blue print of I, III, V semesters of B.Sc. Chemistry for the Academic year 2021--2022.
5. To recommend the Guidelines to be followed by the question paper setters in Chemistry for I, III, V Semester – end exams.
6. To recommend the teaching and evaluation methods to be followed under Autonomous status.
7. Any suggestions regarding certificate course, seminars, workshops, Guest lecture to be organized.
8. Recommend the panel of paper setters and Examiners to the controller of Examinations of autonomous courses of A.G. & S.G.S.Degree colleges of Arts & Science, Vuyyuru.
9. Any other matter.

Chairman.

RESOLUTIONS

- 1) It is resolved to follow the **syllabus of APSCHE (theory and practical) for I semesters of I B.Sc.** under Choice Based Credit System (CBCS) for the Academic year 2021--2022.
- 2) It is resolved to follow the **syllabus of APSCHE (theory and practical) for III semesters of II B.Sc.** under Choice Based Credit System (CBCS) for the Academic year 2021--2022.
- 3) It is resolved to implement the same **syllabus (theory and practical)** under Choice Based Credit System (CBCS 2016-17) for the Academic year 2021-2022 for **V semester of III B.Sc.**
- 4) It is resolved to follow the **Blue prints** as proposed by members of BOS I, III & V semester of Degree B.Sc. for the Academic year 2021-2022.
- 5) It is resolved to follow the **guidelines** to be followed by the question paper setters of Chemistry for I,III & V semesters of Degree B.Sc. for the Academic Year 2021-2022.
- 6) It is resolved to continue the following teaching and evolution methods for Academic year 2021-22.

Teaching Methods:

Besides the conventional methods of teaching, we use modern technology i.e. using of LCD projector to display on U boards etc, for better understanding of concepts.

Evaluation of a student is done by the following procedure:

• Internal Assessment Examinations:

- Out of maximum 100 marks in each paper for I B.Sc, 25 marks shall be allocated for internal assessment. Out of these 25 marks, 15 marks are allocated for announced tests (i.e.IA-1 & IA-2).
- Out of maximum 100 marks in each paper for II,III B.Sc, 30 marks shall be allocated for internal assessment. Out of these 30 marks, **20 marks are allocated for announced tests (i.e.IA-1 & IA-2).**
- Two announced tests will be conducted and average of these two tests shall be deemed as the marks obtained by the student, **5 marks** are allocated on the basis of candidate's **percentage of attendance and remaining 5 marks are allocated for the innovative component like assignment/quiz/seminars for I,II,III B.Sc.**
- There is **no pass minimum** for internal assessment for I, II,III B.Sc.

Semester – End Examination:

- The maximum marks for I B.Sc Semester – End examination shall be 75 marks and 70 marks for II, III B.Sc., duration of the examination shall be 3 hours. Even though the candidate is absent for two IA exams /obtain Zero marks the external marks are considered (if the candidate gets 40/70) and the result shall be declared as “PASS”.
- Semester – End examinations shall be conducted in theory papers at the end of every semester, while in practical papers, these examinations are conducted at the end of I,III, & V semesters **for I, II & III B.Sc** for 50 marks.
- Discussed and recommended for organizing **certificate course, seminars, Guest lecturers, workshops** to upgrade the knowledge of students, for the approval of the academic council.
- Discussed and empowered the Head of the department of Chemistry to suggest the panel of paper setters and examiners to the controller of examinations.
- NIL.

Chairman



A.G & S.G.SIDDHARTHA DEGREE COLLEGE OF ARTS & SCIENCE

Vuyyuru-521165.

NAAC reaccredited at 'A' level

Autonomous -ISO 9001 – 2015 Certified

Title of the Paper: INORGANIC AND PHYSICAL CHEMISTRY

Semester : I

Course Code	CHE-101C	Course Delivery Method	Class Room / Blended Mode -
Credits	3	CIA Marks	25
No. of Lecture Hours / Week	4	Semester End Exam Marks	75
Total Number of Lecture Hours	60	Total Marks	100
Year of Introduction :2017-18	Year of Offering: 2021 - 22	Year of Revision: 2021 - 22	Percentage of Revision: 0

Program outcomes:

Main objectives of this paper is to give a basics, applications and updated knowledge for the students on Chemistry of p , d & f block elements, Theories of bonding in metals, Solid ,Gaseous &Liquid state, Solutions ,ionic equilibrium and Dilute solutions.

Course Outcomes:

At the end of the course, the student will be able to;

1. Understand the basic concepts of p-block elements.
2. Explain the difference between solid, liquid and gases in terms of inter molecular interactions.
3. Apply the concepts of gas equations, pH and electrolytes while studying other chemistry courses.

Syllabus

Course Details

Unit	Learning Units	Lecture Hours
I	<p>1. Chemistry of p-block elements</p> <p>Group 13: Preparation & structure of Diborane, Borazine</p> <p>Group 14: Preparation, classification and uses of silicones</p> <p>Group 15: Preparation & structures of Phosphonitrilic halides $\{(PNCI_2)_n\}$ where $n=3, 4$</p> <p>Group 16: Oxides and Oxoacids of Sulphur (structures only)</p> <p>Group 17: Pseudo halogens, Structures of Interhalogen compounds.</p>	8h
II	<p>1. Chemistry of d-block elements:</p> <p>Characteristics of d-block elements with special reference to electronic configuration, variable valence, magnetic properties, catalytic properties and ability to form complexes. Stability of various oxidation states.</p> <p>2. Chemistry of f-block elements:</p> <p>Chemistry of lanthanides - electronic structure, oxidation states, lanthanide contraction, consequences of lanthanide contraction, magnetic properties. Chemistry of actinides - electronic configuration, oxidation states, actinide contraction, comparison of lanthanides and actinides.</p> <p>3. Theories of bonding in metals:</p> <p>Valence bond theory and free electron theory, explanation of thermal and electrical conductivity of metals based on these theories, Band theory- formation of bands, explanation of conductors, semiconductors and insulators.</p>	16h
PHYSICAL CHEMISTRY		
III	<p>Solid state</p> <p>Symmetry in crystals. Law of constancy of interfacial angles. The law of rationality of indices. The law of symmetry. Miller indices, Definition of lattice point, space lattice, unit cell. Bravais lattices and crystal systems. X-ray diffraction and crystal structure. Bragg's law. Powder method. Defects in crystals. Stoichiometric and non-stoichiometric defects.</p>	10h
IV	<p>1. Gaseous state</p>	10h

	<p>Van der Waal's equation of state. Andrew's isotherms of carbon dioxide, continuity of state. Critical phenomena. Relationship between critical constants and vander Waal's constants. Law of corresponding states. Joule- Thomson effect. Inversion temperature.</p> <p>2. Liquid state</p> <p>Liquid crystals, mesomorphic state. Differences between liquid crystal and solid/liquid. Classification of liquid crystals into Smectic and Nematic. Application of liquid crystals as LCD devices.</p>	
V	<p>1. Solutions</p> <p>Azeotropes-HCl-H₂O system and ethanol-water system. Partially miscible liquids-phenol- water system. Critical solution temperature (CST), Effect of impurity on consolute temperature. Immiscible liquids and steam distillation. Nernst distribution law. Calculation of the partition coefficient. Applications of distribution law.</p> <p>2. Ionic equilibrium</p> <p>Ionic product, common ion effect, solubility and solubility product. Calculations based on solubility product.</p> <p>3. Dilute solutions</p> <p>Colligative properties- RLVP, Osmotic pressure, Elevation in boiling point and depression in freezing point. Experimental methods for the determination of molar mass of a non-volatile. Solute using osmotic pressure, Elevation in boiling point and depression in freezing point. Abnormal colligative properties. Van't Hoff factor.</p>	16h

Reference Books:

1. Principles of physical chemistry by Prutton and Marron
2. Solid State Chemistry and its applications by Anthony R. West
3. Text book of physical chemistry by K L Kapoor
4. Text book of physical chemistry by S Glasstone
5. Advanced physical chemistry by Bahl and Tuli
6. Inorganic Chemistry by J.E. Huheey
7. Basic Inorganic Chemistry by Cotton and Wilkinson
8. A textbook of qualitative inorganic analysis by A.I. Vogel
9. Atkins, P.W. & Paula, J. de Atkin's Physical Chemistry Ed., Oxford University Press

10thEd(2014).

10. Castellan,G.W.Physical Chemistry 4thEd. Narosa (2004).

11. Mortimer,R. G.Physical Chemistry 3rdEd. Elsevier: NOIDA,UP (2009).

12. Barrow,G.M.Physical Chemistry

**A.G. & S.G.SIDDHARTHA DEGREE COLLEGE OF ARTS & SCIENCE
(AUTONOMOUS), VUYYURU.**

SEMESTER-I	PAPER-I	PAPER CODE : CHE-101C
PAPER TITLE : INORGANIC & PHYSICAL CHEMISTRY ACADEMIC YEAR-2021-2022		

Time: 3Hours

Maximum marks: 75

Minimum marks:

PART- A

Answer any FIVE of the following questions. Each carries FIVE marks 5 X 5 = 25 Marks

1. Explain the preparation & structures of Phosphonitrilic compounds. **L2- CO1**
2. Explain in brief, catalytic properties & stability of various oxidation states of d- block elements.
L2-CO2
3. Define Unit Cell , Space Lattice and Lattice Point. **L1- CO3**
4. What are Smectic & Nematic liquid Crystals? Explain. **L1- CO4**
5. Write account on Common ion effect & Solubility product. **L2- CO5**
6. Write a short note on Law of Corresponding States. **L1- CO4**
7. Explain Actinide Contraction. **L2- CO2**
8. Explain the structure of Borazine. **L2- CO1**

PART-B

Answer All of the following questions. Each carries TEN marks 5 X 10 = 50 Marks

9. (a). Explain Classification, Preparations & uses of Silicones **L2- CO1**
(or)
(b). (i). What are Pseudohalogens. **L2- CO1**
(ii). Explain the Structures of any one AX₃& AX₅ interhalogen compounds. **L2- CO1**
10. (a). What is Lanthanide Contraction? Explain the Consequences of Lanthanide Contraction.
L2- CO2
(or)
(b). (i). Explain the magnetic properties of d- block elements. **L2- CO2**
(ii). Explain about Conductors, Semi-Conductors& Insulators using Band Theory. **L2- CO2**

11. (a). Write an essay on Crystal defects. **L1- CO3**

(or)

(b). what is Bragg's Law. Explain the determination of structure of a crystal by powder method.

L2- CO3

12. (a). Derive the relationship between Critical constants & Vander Waal's constants **L1- CO4.**

(or)

(b). (i). Write any 5 differences between liquid crystals & liquids, solids

(ii). Write the applications of Liquid crystals. **L2- CO4**

13. (a). Explain Nernst distribution Law. Explain its applications. **L2- CO5**

(or)

(b). What are colligative properties. Write experimental methods for determination of molar mass of a non-volatile solute by using Elevation in boiling point & depression in freezing point. **L2- CO5**

**A.G.&S.G.SIDDHARTHA DEGREE COLLEGE OF ARTS & SCIENCE
(AUTONOMOUS), VUYYURU.**

(Accredited at “A” Grade by NAAC, Bangalore)

PRACTICAL SYLLABUS

Practical Paper – I Analysis of SALTMIXTURE	PAPER CODE : CHE-101 P ACADEMIC YEAR-2021-2022
--	---

LABORATORY COURSE -I

30hrs (2 h / w)

Practical-I

(At end of Semester-I)

Qualitative inorganic analysis (Minimum of Six mixtures should be analyzed)

Course outcomes:

At the end of the course, the student will be able to;

1. Understand the basic concepts of qualitative analysis of inorganic mixture.
2. Use glassware, equipment and chemicals and follow experimental procedures in the laboratory.
3. Apply the concepts of common ion effect, solubility product and concepts related to qualitative analysis.

Analysis of salt mixture

50 M

Analysis of mixture salt containing two anions and two cations (From two different groups) from the following:

Anions: Carbonate, Sulphate, Chloride, Bromide, Acetate, Nitrate, Borate, Phosphate.

Cations: Lead, Copper, Iron, Aluminium, Zinc, Nickel, Manganese, Calcium, Strontium, Barium, Potassium and Ammonium.

SCHEME OF VALUATION

INTERNAL MARKS

- Record =10 M

EXTERNAL MARKS (40 marks)

- Viva.....10M

PRACTICAL EXAMINATION -30M

- Identification of anion 6M
- Confirmation test for anion 6M
- Group separation table with correct group 10M
- Confirmation test for cation 6 M
- Report 2 M

TOTAL=50 M



A.G & S.G.SIDDHARTHA DEGREE COLLEGE OF ARTS & SCIENCE

Vuyyuru-521165.

NAAC reaccredited at 'A' level

Autonomous -ISO 9001 – 2015 Certified

Title of the Paper : ORGANIC CHEMISTRY AND SPECTROSCOPY

Semester : III

Course Code	CHE-301C	Course Delivery Method	Class Room / Blended Mode -
Credits	3	CIA Marks	30
No. of Lecture Hours / Week	4	Semester End Exam	70
Total Number of Lecture	60	Total Marks	100
Year of Introduction :2017-18	Year of Offering: 2021 - 22	Year of Revision: 2021 - 22	Percentage of Revision: 0

Program outcomes:

Main objectives of this paper is to give a basics, applications and updated knowledge for the students on Chemistry of chemistry of halogenated hydro carbons, chemistry of alcohols and phenols, carbonyl compounds, carboxylic acids, active methylene compounds and spectroscopy.

Course outcomes:

At the end of the course, the student will be able to;

1. Understand preparation, properties and reactions of halo alkanes, halo arenes and oxygen containing functional groups.
2. Use the synthetic chemistry learnt in this course to-do functional group transformations.
3. To propose possible mechanisms for any relevant reaction

Syllabus

Course Details

Unit	Learning Units	Lecture Hours
I	<p>1. Chemistry of Halogenated Hydrocarbons: Nomenclature, any two preparations of Alkyl halides, Aryl halides, Chemical properties (Marks Weightage-5) a. Williamson's synthesis b. substitution vs elimination. c. Relative reactivity of alkyl, allyl, vinyl, benzyl and aryl halides towards nucleophilic substitution reactions. Mechanisms (Marks Weightage-10) SN¹, SN², and SNⁱ Nucleophilic substitution reactions with stereo chemical aspects and effect of solvent.</p> <p>2. Chemistry of Alcohols & Phenols Nomenclature, any two preparations of Alcohols & Phenols Chemical properties (Marks Weightage-5) a. Acidity of phenols and factors affecting it b. Ring substitution reactions (Bromination, Nitration) c. Fries rearrangements d. Kolbe's-Schmidt Reactions, e. Oxidation of diols by periodic acid and lead tetra acetate, Mechanisms (Marks Weightage-10) Reimer-Tieman reaction, Claisen rearrangements, and Pinacol-Pinacolone rearrangement</p>	12h
II	<p>Carbonyl Compounds Nomenclature, any two preparations of (Carbonyl Compounds) Aldehyde and ketones. Chemical properties (Marks Weightage-5) A. Nucleophilic addition reactions of A. NaHSO₃, HCN, RMgx B. Nucleophilic addition reactions with ammonia derivatives, C. Wittig Reaction, Halo form Reaction, Beckmann rearrangements, Michael-addition, Benzoin condensation, Perkin Reaction. and Reformatsky reactions. Reduction reactions: Clemmenson, wolf-kishner, LiAlH₄ and NaBH₄. Mechanisms (Marks Weightage-10)</p>	6h

	Aldol condensation, Cannizzaro Reaction, Baeyer-Villiger oxidation.	
III	<p>Carboxylic Acids and their Derivatives</p> <p>Nomenclature, any two preparations of Carboxylic Acids, and their derivatives.</p> <p>Chemical properties (Marks Weightage-5)</p> <p>A. Reactions involving H, OH and COOH groups- salt formation, anhydride formation, acid chloride formation, amide formation and esterification,</p> <p>B. Huns-Diecker reaction, Schimdt reaction, Curtius rearrangement, Arndt-Eistert synthesis, C. Typical Reactions of dicarboxylic acids, hydroxy acids and unsaturated acids. Reactions of acid chlorides, anhydrides, esters and amides.</p> <p>Mechanisms (Marks Weightage-10)</p> <p>Mechanism of acidic and alkaline hydrolysis of esters, Hell-Volhard- Zelinsky.</p> <p>Active methylene compounds (Marks Weightage-10+5)</p> <p>Acetoacetic esters: keto-enol tautomerism, preparation by Claisen condensation (mechanism), Acid hydrolysis and ketonic hydrolysis. Synthetic applications:Preparation of a) monocarboxylic acids (Acetic acid, Propanoic acid) b) Dicarboxylic acids (Succinic acid, Adipic acid).</p> <p>C) Reaction with urea.</p> <p>Malonic ester: preparation from acetic acid.</p> <p>Synthetic applications: Preparation of a) monocarboxylic acids (Acetic acid, Propanoic acid) b) Dicarboxylic acids (succinic acid and adipic acid) C.Reaction with urea.</p>	16h
SPECTROSCOPY		
IV	<p>Spectrophotometry (Marks Weightage-5+5)</p> <p>General feature of absorption-Beer-Lambert's law and its application, transmittance Absorbance, and molecular absorptivity. Single and double beam Spectrophotometers. Applications of Beer-Lambert's for Quantitative analysis of 1. Chromium in $K_2Cr_2O_7$ 2. Manganese in Manganous sulphate.</p> <p>Electronic spectroscopy: (Marks Weightage-10)</p> <p>Interactions of electromagnetic radiations with molecules and types of molecular spectra. Energy levels of molecular orbital (σ, π, n). Selection rules for electronic spectra. Types of electronic transitions in molecules, effect of conjugation.</p>	18h

	<p>Concept of chromophore and auxochrome.</p> <p>Nuclear Magnetic Resonance (NMR) spectroscopy: (Marks Weightage-10+5)</p> <p>Principles of nuclear magnetic resonance, equivalent and non-equivalent protons, position of signals. Chemical shift, NMR splitting of signals - spin-spin coupling, coupling constants. Applications of NMR with suitable examples - ethyl bromide, ethanol, acetaldehyde, 1,1,2-tribromo ethane, ethyl acetate, toluene and Aceto phenone.</p>	
V	<p>Application of Spectroscopy to Simple Organic Molecules</p> <p>(Marks Weightage-10)</p> <p>Application of visible, ultraviolet and infrared spectroscopy in organic molecules.</p> <p>Application of electronic spectroscopy and Wood ward rules for calculating λ_{max} of conjugated dienes and α, β – unsaturated compounds.</p> <p>Infrared radiation and types of molecular vibrations, functional group and fingerprint region. IR spectra of alkanes, alkenes and simple alcohols (inter and intra molecular hydrogen bonding), aldehydes, ketones, carboxylic acids and their derivatives (effect of substitution on $>C=O$ stretching absorptions).</p>	8h

List of Reference Books

1. A Text Book of Organic Chemistry by Bahl and Arunbahl
2. A Text Book of Organic chemistry by I L Finar Vol I
3. Organic chemistry by Bruice
4. Organic chemistry by Clayden
5. Spectroscopy by William Kemp
6. Spectroscopy by Pavia
7. Organic Spectroscopy by J. R. Dyer
8. Elementary organic spectroscopy by Y.R. Sharma
9. Spectroscopy by P.S.Kalsi
10. Spectrometric Identification of Organic Compounds by Robert M Silverstein, Francis X Webster
11. Mann, F.G. & Saunders, B.C. Practical Organic Chemistry, Pearson Education (2009)

12. Furniss, B.S., Hannaford, A.J., Smith, P.W.G. & Tatchell, A.R. Practical Organic Chemistry, 5th Ed. Pearson (2012).
13. Ahluwalia, V.K. & Aggarwal, R. Comprehensive Practical Organic Chemistry: Preparation and Quantitative Analysis, University Press (2000).

**A.G. & S.G.SIDDHARTHA DEGREE COLLEGE OF ARTS & SCIENCE
(AUTONOMOUS), VUYYURU.**

SEMESTER – III	PAPER-III	PAPER CODE : CHE-301C
PAPER TITLE : ORGANIC CHEMISTRY & SPECTROSCOPY		
ACADEMIC YEAR-2021-2022		

Time: 3Hours

Maximum marks: 70

Minimum marks: 28

SECTION-A

Answer any FOUR of the following. Each question carries 5 marks.

4X5=20

1. Explain relative reactivity of aryl halides.
2. Explain ring substitution reaction (bromination) in phenols.
3. Explain the reaction Beckmann rearrangement.
4. Explain the reaction Curtius-rearrangement.
5. Explain Keto-enol Tautomerism.
6. Write a short note on single beam spectrophotometer.
7. Explain absorbance and molar absorptivity.
8. Write a short note on coupling constant.

SECTION-B

Answer any FIVE questions. Each question carries 10 marks.

5X10=50

9. Discuss the reaction and mechanism of SN^i nucleophilic substitutions.
10. Discuss the reaction and mechanism of Reimer-Tieman.
11. Explain Baeyer-villiger Oxidation reaction with mechanism.
12. Explain mechanism of ester hydrolysis through acidic medium.
13. Write the preparation of n- butyric acid, succinic acid and crotonic acid from malonic ester.
14. Explain the selection rules of electronic spectra.
15. Give the principle and theory involved in PMR spectroscopy.
16. Explain IR spectra of alkanes and alkenes.

The Guidelines to be followed by the question paper setters in chemistry for the

III- Semester - end exams

SEMESTER – III	SUBJECT: CHEMISTRY	COURSE CODE: CHE-301C
PAPER TITLE : ORGANIC CHEMISTRY & SPECTROSCOPY		
ACADEMIC YEAR-2021-2022		

Weightage for the question paper

syllabus	Section-A (Short answer questions)	Section-B (essay questions)
Unit-1 (30 Marks)	1+1	1+1
Unit-2 (15 Marks)	1	1
Unit-3 (30 Marks)	1+1	1+1
Unit-4 (35 Marks)	1+1+1	1+1
Unit-5 (10 Marks)	---	1

- Each Short answer question carries 5 marks in Section –A
- Each Essay question carries 10 marks in Section –B
- The Question papers setters are requested to cover all the topics in the syllabus stipulated as per the weightage given by us.

**A.G.&S.G.SIDDHARTHA DEGREE COLLEGE OF ARTS & SCIENCE
(AUTONOMOUS), VUYYURU.
(Accredited at "A" Grade by NAAC, Bangalore)**

PRACTICAL SYLLABUS

Practical Paper – III Organic preparations and IR Spectral Analysis	PAPER CODE : CHE-301 P ACADEMIC YEAR-2021-2022
--	---

30 hrs (2 h/W) Credits: 2

Organic preparations:

- i. Acetylation of one of the following compounds: amines (aniline, o-, m-, p-toluidines and o-, m-, p-anisidine) and phenols (β -naphthol, vanillin, salicylic acid) by any one method: a. Using conventional method. b. Using green approach
- ii. Benzoylation of one of the following amines (aniline, o-, m-, p- toluidines and o-, m-, p-anisidine).
- iii. Nitration of any one of the following: a. Acetanilide/nitrobenzene by conventional method b. Salicylic acid by green approach (using ceric ammonium nitrate).

IR Spectral Analysis

IR Spectral Analysis of the following functional groups with examples

- a) Hydroxyl groups
- b) Carbonyl groups
- c) Amino groups
- d) Aromatic groups

SCHEME OF VALUATION

1. INTERNAL MARKS- Record-10M
2. EXTERNAL MARKS-40
 - preparations of an organic compound -25M
 - Viva questions = 10 M
 - Project = 5M
 - TOTAL = 50 M

A.G. & S.G.SIDDHARTHA DEGREE COLLEGE OF ARTS & SCIENCE
(AUTONOMOUS), VUYYURU.
(Accredited at "A" Grade by NAAC, Bangalore)

SEMESTER – V	SUBJECT: CHEMISTRY	COURSE CODE: CHE-501C
PAPER TITLE : INORGANIC,ORGANIC & PHYSICAL CHEMISTRY, Paper –V		
ACADEMIC YEAR-2021-2022		

INORGANIC CHEMISTRY

60 hrs(4h/w) Credits-3

UNIT – I

Coordination Chemistry: (10+10+5) 12h

IUPAC nomenclature - bonding theories - Review of Werner's theory and Sidgwick's Concept of coordination - Valence bond theory - geometries of coordination numbers 4-tetrahedral and square planar and 6-octahedral and its limitations, crystal field theory - Splitting of d-orbitals in octahedral, tetrahedral and square-planar complexes - low spin and high spin complexes - factors affecting crystal-field splitting energy, merits and demerits of crystal-field theory. Isomerism in coordination compounds – structural isomerism and stereo isomerism, stereochemistry of complexes with 4 and 6 coordination numbers

UNIT-II

1. Magnetic properties of metal complexes: (10+5) 5h

Types of magnetic behavior, spin-only formula, calculation of magnetic moments, experimental determination of magnetic susceptibility-Gouy method.

2. Stability of metal complexes: (10+5) 6h

Thermodynamic stability and kinetic stability, factors affecting the stability of metal complexes, chelate effect, determination of composition of complex by Job's method and mole ratio method.

ORGANIC CHEMISTRY

UNIT- III

Nitro hydrocarbons: (10+5) 5h

Nomenclature and classification-nitro hydrocarbons, structure -Tautomerism of nitroalkanes leading to aci and keto form, Preparation of Nitroalkanes, reactivity-halogenation, reaction with HONO (Nitrous acid), Nef reaction and Mannich reaction leading to Michael addition and reduction.

UNIT – IV

Nitrogen compounds: (10+10+5)

16h

Amines (Aliphatic and Aromatic): Nomenclature, Classification into 1°, 2°, 3° Amines and Quaternary ammonium compounds. Preparative methods – 1. Ammonolysis of alkyl halides 2. Gabriel synthesis 3. Hoffman's bromide reaction (mechanism). Reduction of Amides and Schmidt reaction. Physical properties and basic character - Comparative basic strength of Ammonia, methyl amine, dimethyl amine, tri methyl amine and aniline - comparative basic strength of aniline, N-methyl aniline and N,N-dimethyl aniline (in aqueous and non-aqueous medium), steric effects and substituent effects.

Chemical properties: a) Alkylation b) Acylation c) Carbylamines reaction d) Hinsberg separation e) Reaction with Nitrous acid of 1°, 2°, 3° (Aliphatic and aromatic amines). Electrophilic substitution of Aromatic amines – Bromination and Nitration. Oxidation of aryl and Tertiary amines, Diazotization.

PHYSICAL CHEMISTRY

UNIT- V

Thermodynamics (10+5+5)

16h

The first law of thermodynamics-statement, definition of internal energy and enthalpy. Heat capacities and their relationship. Joule-Thomson effect- coefficient. Calculation of w , for the expansion of perfect gas under isothermal and adiabatic conditions for reversible processes. State function. Temperature dependence of enthalpy of formation-Kirchhoff's equation. Second law of thermodynamics. Different Statements of the law. Concept of entropy, entropy as a state function, entropy changes in reversible and irreversible processes. Entropy changes in spontaneous and equilibrium processes.

List of Reference Books

1. Concise coordination chemistry by Gopalan and Ramalingam
2. Coordination Chemistry by Basalo and Johnson
3. Organic Chemistry by G.Mare loudan, Purdue Univ
4. Advanced Physical Chemistry by
5. Text book of physical chemistry by S Glasstone
6. Concise Inorganic Chemistry by J.D.Lee

A.G. & S.G.SIDDHARTHA DEGREE COLLEGE OF ARTS & SCIENCE
(AUTONOMOUS), VUYYURU.
(Accredited at “A” Grade by NAAC, Bangalore)

SEMESTER – V	PAPER-V	PAPER CODE : CHE-501C
PAPER TITLE : INORGANIC,ORGANIC & PHYSICAL CHEMISTRY ACADEMIC YEAR-2021-2022		

Time: 3Hours

Maximum marks: 70

Minimum marks: 28

SECTION-A

Answer any FOUR of the following. Each question carries 5 marks.

4X5=20

1. Define Crystal field energy? Explain the factors affecting Crystal field energy?
2. Write short note on Magnetic behavior of metal complexes.
3. Define Stability constant? Explain Thermodynamic and kinetic stability.
4. Explain Tautomerism of Nitro alkanes.
5. Write comparative study of Basic strength of Aniline, N-methyl aniline and N,N dimethyl aniline.
6. Define the following terms (a) Enthalpy (b) Internal energy.
7. Explain entropy changes in Spontaneous and Non –Spontaneous processes.

SECTION-B

Answer any FIVE questions. Each question carries 10 marks. 5X10=50

8. Explain VBT of coordination compounds
9. Explain Crystal field splitting Theory
10. Describe Gouy's method
11. Explain Factors affecting the stability of Metal complexes.
12. What are Nitro alkanes ? write any two preparation methods and two chemical reactions.
13. What are amines? Write any four chemical reactions of amines
14. Write about Electrophilic substitution of Aromatic amines
15. Define an equation for work done of an ideal gas under isothermal and adiabatic process.

**The Guidelines to be followed by the question paper setters in chemistry for the
V- Semester - end exams**

SEMESTER – V SUBJECT: CHEMISTRY COURSE CODE: CHE-501C
PAPER TITLE : INORGANIC,ORGANIC & PHYSICAL CHEMISTRY, Paper –V ACADEMIC YEAR-2021-2022

Weightage for the question paper

syllabus	Section-A (Short answer questions)	Section-B (essay questions)
Unit-1 (25 Marks)	1	1 + 1
Unit-2 (30 Marks)	1 + 1	1+1
Unit-3 (15 Marks)	1	1
Unit-4 (25 Marks)	1	1 + 1
Unit-5 (20Marks)	1 +1	1

- Each Short answer question carries 5 marks in Section –A
- Each Essay question carries 10 marks in Section –B
- The Question papers setters are requested to cover all the topics in the syllabus stipulated as per the weightage given by us.

**A.G. & S.G.SIDDHARTHA DEGREE COLLEGE OF ARTS & SCIENCE
(AUTONOMOUS), VUYYURU.
(Accredited at “A” Grade by NAAC, Bangalore)
PRACTICAL SYLLABUS**

Practical Paper – V Organic Qualitative Analysis	PAPER CODE : CHE-501 P ACADEMIC YEAR-2021-2022
---	---

30 hrs (2 h/W) Credits: 2

Organic Qualitative Analysis:

50M

Analysis of an organic compound through systematic qualitative procedure for functional group identification including the determination of melting point and boiling point .

Alcohols, Phenols, Aldehydes, Ketones, Carbohydrates, Carboxylic acids, Aromatic Primary Amines.

SCHEME OF VALUATION

1. INTERNAL MARKS- Record-10M
2. EXTERNAL MARKS-40
 - Analysis of an organic compound and preparation of suitable derivative-30M
 - Viva questions = 10 M

TOTAL = 50 M

**A.G. & S.G.SIDDHARTHA DEGREE COLLEGE OF ARTS & SCIENCE
(AUTONOMOUS),VUYYURU.**

(Accredited at "A" Grade by NAAC, Bangalore)

SEMESTER – V Paper – VI SUBJECT: CHEMISTRY PAPER CODE: CHE-502C
PAPER TITLE : INORGANIC,ORGANIC & PHYSICAL CHEMISTRY ACADEMIC YEAR-2021-2022

60 hrs (4h/w) Credits-3

INORGANIC CHEMISTRY

UNIT-I

1. Reactivity of metal complexes: (10+5) 5h

Labile and inert complexes, ligand substitution reactions - SN^1 and SN^2 , substitution reactions of square planar complexes - Trans effect and applications of Trans effect.

2. Bio inorganic chemistry: (10) 5h

Essential elements, biological significance of Na, K, Mg, Ca, Fe, Co, Ni, Cu, Zn and Cl. Metallo porphyrins – Structure and functions of hemoglobin, Myoglobin and Chlorophyll.

ORGANIC CHEMISTRY

UNIT- II

Heterocyclic Compounds (10+5) 10h

Introduction and definition: Simple five membered ring compounds with one hetero atom Ex. Furan. Thiophene and pyrrole - Aromatic character – Preparation from 1,4,-dicarbonyl compounds, Paul-Knorr synthesis. Properties: Acidic character of pyrrole - electrophilic substitution at 2 or 5 position, Halogenation, Nitration and Sulphonation under mild conditions - Diels Alder reaction in furan. Pyridine – Structure - Basicity - Aromaticity - Comparison with pyrrole - one method of preparation and properties - Reactivity towards Nucleophilic substitution reaction.

UNIT-III

Carbohydrates (10+5+5+5)

12h

Monosaccharide's: Glucose (aldo hexose) - Evidence for cyclic structure of glucose (some negative aldehydes tests and mutarotation) - Proof for the ring size (methylation, hydrolysis and oxidation reactions) - Pyranose structure (Haworth formula and chair conformational formula).

Fructose (ketohexose) - Evidence of 2 - ketohexose structure (formation of pent acetate, formation of cyanohydrin its hydrolysis and reduction by HI). Cyclic structure for fructose (Furanose structure and Haworth formula) - osazone formation from glucose and fructose – Definition of anomers with examples.

Interconversion of Monosaccharide's: Aldopentose to Aldohexose (Arabinose to D- Glucose, D-Mannose) (Kiliani - Fischer method). Epimers, Epimerisation - Lobry de bruyn van Ekenstein rearrangement. Aldohexose to Aldopentose (D-Glucose to D- Arabinose) by Ruff degradation. Aldohexose to Ketohexose [(+) Glucose to (-) Fructose] and Ketohexose to Aldohexose (Fructose to Glucose)

UNIT- IV

Amino acids and proteins (10+10+5)

12h

Introduction: Definition of Amino acids, classification of Amino acids into alpha, beta, and gamma amino acids. Natural and essential amino acids - definition and examples, classification of alpha amino acids into acidic, basic and neutral amino acids with examples. Methods of synthesis: General methods of synthesis of alpha amino acids (specific examples - Glycine, Alanine, valine and leucine) by following methods: a) from halogenated carboxylic acid b) Malonic ester synthesis c) strecker's synthesis.

Physical properties: Zwitter ion structure - salt like character - solubility, melting points, amphoteric character, definition of isoelectric point.

Chemical properties: General reactions due to amino and carboxyl groups-lactams from gamma and delta amino acids by heating peptide bond (amide linkage). Structure and nomenclature of peptides and proteins.

Mass Spectrometry: (10M)

6h

Basic principles-Molecular ion/parent ion, fragment ions/daughter ions. Theory-formation of parent ions. Representation of mass spectrum. Identification of parent ion, (M+1),(M+2), base

peaks (relative abundance 100%) Determination of molecular formula-mass spectra of ethyl benzene, acetophenone, 1-propanol.

PHYSICAL CHEMISTRY

UNIT-V

1. Chemical kinetics (10+5)

10h

Rate of reaction - Definition of order and molecularity. Derivation of rate constants for first, second, third and zero order reactions and examples. Derivation for time half change. Methods to determine the order of reactions. Effect of temperature on rate of reaction, Arrhenius equation, concept of activation energy.

List of Reference Books

1. Concise coordination chemistry by Gopalan and Ramalingam
2. Coordination Chemistry by Basalo and Johnson
3. Organic Chemistry by G.Mare loudan, Purdue Univ
4. Advanced Physical Chemistry by Atkins
5. Text book of physical chemistry by S Glasstone

**A.G. & S.G.SIDDHARTHA DEGREE COLLEGE OF ARTS & SCIENCE
(AUTONOMOUS), VUYYURU.**

(Accredited at "A" Grade by NAAC, Bangalore)

SEMESTER – V	PAPER-VI	PAPER CODE : CHE-502C
PAPER TITLE : INORGANIC,ORGANIC & PHYSICAL CHEMISTRY		
ACADEMIC YEAR-2021-2022		

Time: 3Hours

Maximum marks: 70

Minimum marks: 28

SECTION-A

Answer any FOUR of the following. Each question carries 5 marks.

4X5=20

1. Explain labile and inert complex with suitable examples.
2. Explain the aromatic character of pyrrole.
3. Write the classification of Carbohydrates with suitable examples
4. How do you convert Ketohexose to Aldohexose.
5. Write a note on Ruff's degradation of an Aldohexose.
6. Write the preparation of lactams from gamma and delta amino acids
7. What is Zero order reaction? give examples

SECTION-B

Answer any FIVE questions. Each question carries 10 marks. 5X10=50

8. Explain uni molecular and bi molecular nucleophilic substitution reactions and write mechanism of nucleophilic substitution in square planar complexes.
9. Explain the role of Fe, Co, Zn in biological systems.
10. What are Hetero cyclic compounds? Write the preparation and properties of Furan.
11. Explain the structure of Fructose.
12. What are amino acids and proteins? Give two methods of preparation of α -amino acids with equations.
13. Give reactions to show the presence of NH_2 and COOH groups in α -amino acids.
14. Write the principles of Mass spectrometry.
15. Define order of the reaction. Explain any three methods for the determination of the order of the reaction

**The Guidelines to be followed by the question paper setters in chemistry for the
V- Semester - end exams**

SEMESTER – V	SUBJECT: CHEMISTRY	PAPER CODE: CHE-502C
PAPER TITLE : INORGANIC,ORGANIC & PHYSICAL CHEMISTRY, Paper – VI		
ACADEMIC YEAR-2021-2022		

Weightage for the question paper

syllabus	Section-A (Short answer questions)	Section-B (essay questions)
Unit-1 (25 Marks)	1	1 + 1
Unit-2 (15 Marks)	1	1
Unit-3 (25 Marks)	1 + 1+1	1
Unit-4 (35 Marks)	1	1 + 1 +1
Unit-5 (15 Marks)	1	1

- Each Short answer question carries 5 marks in Section –A
- Each Essay question carries 10 marks in Section –B
- The Question papers setters are requested to cover all the topics in the syllabus stipulated as per the weightage given by us.

**A.G. & S.G.SIDDHARTHA DEGREE COLLEGE OF ARTS & SCIENCE (AUTONOMOUS),
VUYYURU.**

(Accredited at "A" Grade by NAAC, Bangalore)

PRACTICAL SYLLABUS

Practical Paper –VI Physical Chemistry	COURSE CODE : CHE-502 P ACADEMIC YEAR-2021-2022
---	--

30 hrs (2 h/W) Credits: 2

1. Determination of rate constant for acid catalyzed ester hydrolysis.
2. Determination of molecular status and partition coefficient of benzoic acid in Benzene and water.
3. Determination of Surface tension of liquid
4. Determination of Viscosity of liquid.
5. Adsorption of oxalic acid on silica gel, verification of Freundlich isotherm.

SCHEME OF VALUATION

1. INTERNAL MARKS- Record-10M
2. EXTERNAL MARKS-40
 - Practical-30M
 - Viva questions = 10 M

TOTAL = 50 M

**AG & SG SIDDHARTHA DEGREE COLLEGE OF ARTS &
SCIENCE(AUTONOMOUS)VUYYURU-521165**

Aided by the Government of A.P, Re-Accredited by NAAC with 'A' Grade

08676-233267



PG Department of Chemistry

Minutes of the meeting of Board of Studies

11-11-2021

MINUTES OF BOARD OF STUDIES

Minutes of meeting of Board of studies in PG Department of Chemistry held on 11-11-2021 at 7.00 pm in the PG Department of Chemistry through online(Google meet)

Members Present

S.No	NAME		Signature
1	Dr. V.Sreeram Head, Dept. of Chemistry(P.G) AG & SG S College, Vuyyuru.	Chairman	
2	Prof.C.Suresh Reddy Department of Chemistry S.V. University, Tirupati.	University Nominee	
3	Prof. Koya Prabakar Rao Department of Chemistry Vignan University, Guntur.	Subject Expert	
4	Dr.M.Sivanath Associate prof. Dept. of Chemistry A.N.R.College, Gudivada.	Subject Expert	
5	Dr.G.Raja Manager(Q.A) Biophore India pharamaceuticals. Hyderabad.	Representative from Industry	
6	Abdul Raheem	One Post Graduate Meritorious Aluminous nominated by the Principal	
7	N.V.Srinivasa Rao Department of Mathematics AG & SG S College, Vuyyuru.	Representative Science Faculty Other Dept.	
8	V.N.V.Kishore Dept. of Chemistry(P.G) AG & SG S College, Vuyyuru	Member	
9	Dilshad Begum Dept. of Chemistry(P.G) AG & SG S College, Vuyyuru	Member	
10	M.Rekha Dept. of Chemistry(P.G) AG & SG S College, Vuyyuru	Member	

AGENDA:

1. To prepare syllabus and model question papers, discuss & approve modalities of lab courses.
2. To Suggest methodologies for innovative methods of teaching
3. Any other matter with the permission of the Chair.

Resolution –I

1. Resolved to recommend the Chairman, Syllabi & Model Question Papers for theory courses and modalities for evaluation of Lab Courses, Assignments etc., for Internal Assessment Tests and Semester End Examinations separately.

2. ***Resolution –II***

Resolved to adopt online teaching methods like as ZOOM, Microsoft teams, Google meet etc for ICT(Information and communication technologies) teaching

Resolution –III

3. Nil

BOS Meeting- PG Chemistry-11-11-2021, 7.00PM.through Online (Google Meet)

Syllabus approval letter through mail.

1 Prof.C.Suresh Reddy

Dear Dr. Sreeram

Greetings of the day

Happy to participate In the today's BOS meeting. I have gone through the syllabus and it is fine. I am here with approving the same syllabus.

This is for your kind information and necessary action in this regard.

Prof .C.Suresh Reddy

Prof. C. Suresh Reddy, FAPAS, MNASc

Department of Chemistry

S.V.U. College of Sciences

Sri Venkateswara University

Tirupati-517 502, A.P., India

Mobile: 98496 94958

2.Prof.K.prabhakara Rao

Dear sir,

I am here accepting the proposed syllabus. Thank you.

Warm regards

Prof. Koya Prabhakara Rao

Ph.D. (IIT Madras) (Postdoc-Japan 5yrs)

Head, Division of Chemistry

VGF-8&9A, H-Block

Department of Science and Humanities

VFSTR (Deemed to be University), Vadlamudi,

Guntur Dt, Pincode: 522213, Andhra Pradesh India.

Phone (Office): 918632344762, Mobile: +919676157858

Email: drkpr_sh@vignan.ac.in; kprao2005@gmail.com

website1:<https://sites.google.com/site/drkoyaprabhakararaowebiste/>

website2:<http://www.vignan.ac.in/bshprabhakararao.php>

3. Dr.M.Sivanath

I have gone through your mail regarding the Third & First semester and open elective Syllabus.

It is fine and approved.

This is for your kind information and necessary action in this regard.

Warm regards

Dr.M.Sivanath,

Associate prof., Dept. of Chemistry, sivanath23@gmail.com

Vice principal, Additional Director, ANR College, Gudivada

A.G. & S.G.SIDDHARTHA DEGREE COLLEGE OF ARTS & SCIENCE
(Autonomous)
DEPARTMENT OF CHEMISTRY
M.Sc – CHEMISTRY (ORGANIC CHEMISTRY)

Appendix - I

Scheme of Instruction and Evaluation for **M.Sc. (Organic Chemistry)** programme for
the batch of students admitted during 2021 – 2022

Semester – I

Paper	Title of the Paper	Instruction Hours Per Week			Credits(T+P)	Evaluation		
		L	T	P		CIA MARKS	SEE	
							MARKS	DURATION
Paper-I	General Chemistry	4	1	--	4	30	70	3 hours
Paper-II	Inorganic Chemistry - I	4	1	--	4	30	70	3 hours
Paper-III	Organic Chemistry - I	4	1	--	4	30	70	3 hours
Paper-IV	Physical Chemistry - I	4	1	--	4	30	70	3 hours
Pract-I	Inorganic Chemistry	--	--	6	3	30	70	6 hours
Pract-II	Organic Chemistry	--	--	6	3	30	70	6 hours
	Sub-Total	16	4	12	16+4+12=32			



A.G. & S.G. SIDDHARTHA DEGREE COLLEGE OF ARTS & SCIENCE

Vuyyuru- 521165.

NAAC reaccruited at 'A' level

Autonomous -ISO 9001 – 2015 Certified

Title of the Paper: GENERAL CHEMISTRY

Semester: I

Course Code	20CH1T1	Course Delivery Method	Class Room / Blended Mode - Both
Credits	4	CIA Marks	30
No. of Lecture Hours / Week	4	Semester End Exam Marks	70
Total Number of Lecture Hours	60	Total Marks	100
Year of Introduction :2020-21	Year of Offering: 2021 - 22	Year of Revision: 2021-22	Percentage of Revision: 40 % (Unit-V is shuffled from 21CH1T4 TO 21CH1T1).

Course Objective: The main objective of this paper is to give a basic and updated knowledge for the students on Treatment of analytical data, Titrimetric Analysis, Rotational-Vibrational Spectroscopy, Symmetry and Group theory in chemistry.

Course Outcomes:-

CO1: Recollect the concepts of titrimetric analysis, specific statistical rules, microwave Spectroscopy, rotational vibrational spectroscopy and group theory in chemistry

CO2: Identify the role of titrimetric analysis, specific statistical rules, microwave spectroscopy, Rotational vibrational spectroscopy and group theory in chemistry.

CO3: Demonstrate knowledge of titrimetric analysis, microwave spectroscopy, rotational Vibrational spectroscopy and group theory in chosen job role.

CO4: Test the conceptual knowledge gained in titrimetric analysis, statistical rules / principles, Microwave spectroscopy, rotational vibrational spectroscopy and group theory in chemistry.

Syllabus

Course Details:-

Unit	Learning Units	Lecture Hours
I	Treatment of analytical data : Classification of errors – Determinate and indeterminate errors –Minimisation of errors – Accuracy and precision – Distribution of random errors – Gaussian distribution – Measures of central tendency – Measures of precision – Standard deviation – Standard error of mean – student's t test – Confidence interval of mean – Testing for significance – Comparison of two means – F – test – Criteria of rejection of an observation – propagation of errors – Significant figures and computation rules – Control charts – Regression analysis – Linear least squares analysis.	12
II	Titrimetric Analysis: Classification of reactions in titrimetric analysis-Primary and secondary standards-Neutralisation titrations-Theory of Neutralization indicators-Mixed indicators- Neutralisation curves-Displacement titrations-Precipitation titrations-Indicators for precipitation titrations-Volhard method-Mohr method- Theory of adsorption indicators-Oxidation reduction titrations-Change of electrode potentials during titration of Fe(II) with Ce(IV)- Detection of end point in redox titrations-Complexometric titrations- Metal ion indicators-Applications of EDTA titrations-Titration of cyanide with silver ion.	12
III	Introduction to Molecular Spectroscopy: Motion of molecules-Degrees of freedom –Energy associates with the degrees of freedom-Type of spectra. Microwave spectroscopy: Classification of molecules, rigid rotator model, effect of isotopic substitution on the transition frequencies, Intensities non-rigid rotator-Microwave spectra of polyatomic molecules.	12
IV	Rotational Vibrational Spectroscopy: Harmonic oscillator, vibrational energies of diatomic molecules, zero-point energy, force constant and bond strengths, anharmonicity, Morse potential energy diagram. Vibration – rotation spectroscopy. PQR branches, Born–Openheimer approximation, selection rules, normal modes of vibration, group frequencies, overtones, hot bands, applications.	12
V	Symmetry and Group theory in chemistry: Symmetry elements, symmetry operation, definition of group, sub group, relation between order of a finite group and its sub group. GMT tables Abelian and non-abelian groups. Point group. Schonfiles symbols, Find out Point group of a molecule (yes or no Method). Representation of groups by Matrices (representation for the C_n , C_{nv} , C_{nh} , D_n etc. groups to be worked out, explicitly). Character of a representation. The great Orthogonality theorem (without proof) and its importance. Character tables and their use. Construction of Character tables.	12

Reference Books:

1. Vogel's text book of quantitative analysis. (3rd edition)Addition Wesley Longmann Inc.
2. Quantitative analysis R.A Day and A.L.Underwood. Prentice Hall Pvt.Ltd.
3. Fundamentals of Analytical Chemistry – Skoog and West
4. Instrumental Methods of analysis – B K Sharma.

Course Focus: Employability & Entrepreneurship.



A.G. & S.G. SIDDHARTHA DEGREE COLLEGE OF ARTS & SCIENCE

Vuyyuru-521165.

NAAC reaccredited at 'A' level
Autonomous -ISO 9001 – 2015 Certified

Title of the Paper: INORGANIC CHEMISTRY-I

Semester: I

Course Code	20CH1T2	Course Delivery Method	Class Room / Blended Mode - Both
Credits	4	CIA Marks	30
No. of Lecture Hours / Week	4	Semester End Exam Marks	70
Total Number of Lecture Hours	60	Total Marks	100
Year of Introduction :2020-21	Year of Offering: 2021 - 22	Year of Revision: 2021-22	Percentage of Revision: 0%

Course Objective: The main objective of this paper is to give a basic and updated knowledge for the students on Quantum Mechanics, Chemistry of non- transition elements, Structure and Bonding, Metal–ligand bonding, Metal – ligand Equilibria in solutions.

Course Outcomes:-

After completion of the course, the student will be able to

CO1 : Memorize the basic concepts of Quantum chemistry, Co-ordination chemistry and Chemical Bonding.

CO2 : Comprehend the role of basic and advanced concepts of Quantum chemistry, Co-ordination Chemistry and Chemical bonding.

CO3 : Execute the conceptual knowledge gained in the concepts of Quantum chemistry, Co-ordination Chemistry and Chemical bonding in chosen job role

CO4 : Compare and distinguish one concept from the other in inorganic chemistry and in correlation With other chemistries as well

Syllabus

Course Details

Unit	Learning Units	Lecture Hours
I	<p>Introduction to Exact Quantum Mechanical Results: Schrodinger equation, importance of wave function, Operators, Eigen values and Eigen functions, derivation of wave equation using operator concept. Discussion of solutions of Schrodinger's equation to some model systems viz. particle in one dimensional box (applications), three-dimensional box, Rigid rotator system and the Hydrogen atom. Variation theorem, linear variation principle, perturbation theory (first order and non-degenerate), Application of variation method to the Hydrogen atom</p>	12
II	<p>Chemistry of non- transition elements: Halogen oxides and oxyfluorides, Spectral and Magnetic properties of Lanthanides and Actinides. Analytical applications of Lanthanides and Actinides. Synthesis, properties and structure of B-N, S-N, P-N cyclic compounds. Intercalation compounds.</p> <p>Metal π- complexes: preparation, structure and bonding in Nitrosyl, Dinitrogen and Dioxygen complexes.</p>	12
III	<p>Structure and Bonding: $p\pi-d\pi$ bonding, Bent's rule, Non-valence cohesive forces, VSEPR theory. Molecular Orbital theory, Molecular orbitals in triatomic (BeH_2) molecules and ions (NO_2^-) and energy level diagrams. Walsh diagrams for linear (BeH_2) and bent (H_2O) molecules</p>	12
IV	<p>Metal-ligand bonding: Crystal Field Theory of bonding in transition metal complexes-Splitting of d-orbitals in octahedral, tetrahedral, square planar, Trigonal bipyramidal and Square pyramidal fields. Tetragonal distortions - Jahn-Teller effect. Applications and limitations of CFT. Experimental evidences for covalence in complexes. Molecular Orbital Theory of bonding for Octahedral, tetrahedral and square planar complexes. π-bonding and MOT - Effect of π - donor and π -acceptor ligands on Δ_o. Experimental evidence for π - bonding in complexes</p>	12
V	<p>Metal – ligand Equilibria in solutions: Step wise and over all formation constants. Trends in stepwise constants (statistical effect and statistical ratio). Determination of formation constants by Spectrophotometric method (Job's method) and pH metric method (Bjerrum's).</p> <p>Stability correlations - Irving -William's series. Hard and soft acids and bases (HSAB).</p>	12

Reference Books:

1. Inorganic Chemistry Huheey, Harper and Row.
2. Physical methods in inorganic chemistry, R.S. Drago. Affiliated East-West Pvt. Ltd.
3. Concise inorganic chemistry, J. D. Lee, ELBS.
4. Modern Inorganic Chemistry , W. L. Jolly, McGrawHill.
5. Inorganic Chemistry , K. F. Purcell and J. C. Kotz Holt Saunders international.
6. Concepts and methods of inorganic chemistry , B. E. Douglas and D.H.M.C.
7. Daniel, oxford Press.
8. Introductory quantum mechanics , A. K. Chandra
9. Quantum Chemistry ,R. K. Prasad.
10. Inorganic Chemistry ,Atkins, ELBS
11. Advanced Inorganic Chemistry ,Cotton and Wilkinson, Wiley Eastern
12. Quantum Chemistry, Levine.
13. Text book of Coordination chemistry ,K.SomaSekhar rao and K.N.K. Vani, Kalyani Publishers .
14. Theoretical Inorganic Chemistry by G.S.Manku, Tata Mc GrawHill, 2000, reprint.
15. Concise co-ordination chemistry, R.Gopal, Ramalingam, Vikas Publishing, House, 2014.
16. Inorganic Chemistry – Huheey, A.Keiter, L.Keiter, 4th edition, Pearson education, Asia.

Course Focus: Employability & Entrepreneurship.



A.G. & S.G. SIDDHARTHA DEGREE COLLEGE OF ARTS & SCIENCE

Vuyyuru-521165.

NAAC reaccruited at 'A' level

Autonomous -ISO 9001 – 2015 Certified

Title of the Paper: ORGANIC CHEMISTRY-I

Semester: I

Course Code	20CH1T3	Course Delivery Method	Class Room / Blended Mode - Both
Credits	4	CIA Marks	30
No. of Lecture Hours / Week	4	Semester End Exam Marks	70
Total Number of Lecture Hours	60	Total Marks	100
Year of Introduction :2020-21	Year of Offering: 2021 - 22	Year of Revision: 2021-22	Percentage of Revision: 0%

Course Objective: The main objective of this paper is to give a basic and updated knowledge for the students on Nature of bonding and Aromaticity, Reactive intermediates & Reactive Species, Addition Reactions, Eliminations Reactions, Substitution Reactions

Course Outcomes:

After completion of the course, the student will be able to:

- CO1 :** Recollect the basic concepts of aromaticity, reactive intermediates, addition, elimination and Substitution reactions
- CO2 :** Explain the basic and advanced concepts of aromaticity, reactive intermediates, addition, Elimination and substitution reactions.
- CO3 :** Solve high level concepts in organic chemistry with conceptual knowledge gained in aromaticity, Reactive intermediates, addition, elimination and substitution reactions
- CO4 :** Exercise the knowledge about aromaticity, reactive intermediates, addition, elimination and Substitution reactions in understanding the properties of organic compounds.

Syllabus

Course Details

Unit	Learning Units	Lecture Hours
I	<p>Nature of bonding: Localised and Delocalized, Delocalised chemical bonding conjugation, cross conjugation, hyper conjugation, Tautomerism.</p> <p>Aromaticity: Concept of Aromaticity, Aromaticity of five membered, six membered rings - Non benzenoid aromatic compounds:- cyclopropenyl cation, Cyclobutadienyldication, cyclopentadienyl anion-tropyllium cation and cyclooctatetraenyl dianion. Homoaromaticity, Anti aromaticity</p>	12
II	<p>Reactive intermediates & Reactive Species:</p> <p>Reactive intermediates: Generation, Structure, Stability, Detection and Reactivity of Carbocations, Carbanions, Free radicals, Carbenes, Nitrenes and Arynes.</p> <p>Reactive Species: Generation and reactivity of Electrophiles, Nucleophiles, Dienophiles, Ylids.</p>	12
III	<p>Addition Reactions: Additions: Addition to carbon – carbon multiple bonds, HX, X₂, HOX, stereo chemistry of addition, formation and reaction of epoxides, syn and anti hydroxylation, hydrogenation(catalytic and Non catalytic), synthetic reactions of CO and CN and Cram's rule.</p>	12
IV	<p>Eliminations Reactions:Types of elimination (E1, E1cB, E2) reactions, mechanisms, stereochemistry and orientation, Hofmann and Saytzeff's rules, Syn elimination versus anti elimination. Competitions between elimination and substitution. Dehydration, dehydrogenation, dehalogenation, decarboxylative elimination, pyrolytic eliminations.</p>	12
V	<p>Substitution Reactions:</p> <p>Aliphatic Nucleophilic substitutions:The SN², SN¹, mixed SN¹ and SN² and SNⁱ reactions : Mechanism, effect of structure, nucleophile, leaving group on substitutions. The neighbouring group mechanism, participation by σ and π bonds, anchimeric assistance.</p> <p>Aromatic Nucleophilic substitution:The SN^{Ar} (Addition – Elimination), SN¹(Ar) mechanisms and benzyne mechanism (Elimination – Addition). Reactivity- effect of substrate structure, leaving group and attacking nucleophile. The Von-Richter, Sommelet – Hauser and Smiles rearrangements.</p>	12

Reference Books:

1. Advanced organic chemistry- Reaction, mechanism and structure, Jerry March, John Wiley.
2. Advanced organic chemistry, F.A. Carey and R.J. Sundberg, Springer, New York.
3. A guide book to Mechanism in organic chemistry, Peter Sykes, Longman.
4. Organic chemistry, I.L. Finar, Vol. I & II, Fifth ed. ELBS.
5. Organic chemistry, Hendrickson, Cram and Hammond (McGraw – Hill).
6. Modern organic Reactions, H.O. House, Benjamin.
7. Structure and mechanism in organic chemistry, C.K. Ingold, Cornell University Press.
8. Principles of organic synthesis, R.O.C. Norman and J.M. Coxon, Blakie Academic & Professional.
9. Reaction Mechanism in Organic Chemistry, S.M. Mukherji and S.P. Singh, Macmillan.
10. Basic Principles of Organic Chemistry by J. B. Roberts and M. Caserio.

Course Focus: Employability & Entrepreneurship.



A.G. & S.G. SIDDHARTHA DEGREE COLLEGE OF ARTS & SCIENCE

Vuyyuru-521165.

NAAC reaccredited at 'A' level

Autonomous -ISO 9001 – 2015 Certified

Title of the Paper: PHYSICAL CHEMISTRY-I

Semester: I

Course Code	20CH1T4	Course Delivery Method	Class Room / Blended Mode - Both
Credits	4	CIA Marks	30
No. of Lecture Hours / Week	4	Semester End Exam Marks	70
Total Number of Lecture Hours	60	Total Marks	100
Year of Introduction : 2020-2021	Year of Offering: 2021 - 22	Year of Revision:2021-22	Percentage of Revision: 20%

Course Objective: The main objective of this paper is to give a basic and updated knowledge for the students on Thermodynamics, Surface phenomena and phase equilibria, Electrochemistry, Chemical kinetics, Potentiometry.

Course Outcomes:-

After the completion of the course, Students will be able to

- CO1 : Recall the basic concepts of thermodynamics, surface chemistry, electrochemistry, chemical Kinetics and potentiometry in detail.
- CO2 : Apply the spontaneous and non spontaneous reaction and derive various thermodynamic and Chemical kinetic derivations.
- CO3 : Describe the physical significance of thermodynamics, chemical kinetics and electrochemistry in Explaining the chemical properties and reactivity of molecules.
- CO4 : Analyse the important techniques of surfaces with the help of ESCA, Auger electron spectroscopy and potentiometric techniques of complexometric, neutralization, oxidation and reduction Titrations.

Syllabus

Course Details

Unit	Learning Units	Lecture Hours
I	<p>Thermodynamics - I Classical thermodynamics - Brief review of first and second laws of thermodynamics - Entropy change in reversible and irreversible processes - Entropy of mixing of ideal gases - Entropy and disorder – Free energy functions - Gibbs-Helmholtz equation - Maxwell partial relations - Conditions of equilibrium and spontaneity - Free energy changes in chemical reactions: Van't Hoff reaction isotherm - Van't Hoff equation - Clausius Clapeyron equation - partial molar quantities - Chemical potential - Gibbs- Duhem equation - partial molar volume - determination of partial molar quantities - Fugacity - Determination of fugacity - Thermodynamic derivation of Raoult's law..</p>	12
II	<p>Surface phenomena and phase equilibria - Surface tension - capillary action - pressure difference - across curved surface (young - Laplace equation) - Vapour pressure of small droplets (Kelvin equation) - Gibbs-Adsorption equation - BET equation - Estimation of surface area - catalytic activity of surfaces – ESCA , X- ray fluorescence and Auger electron spectroscopy.</p> <p>Surface active agents - classification of surface active agents - Micellization - critical Micelle concentration (CMC) - factors affecting the CMC of surfactants, microemulsions - reverse micelles - Hydrophobic interaction.</p>	12
III	<p>Electrochemistry – I - Electrochemical cells - Measurement of EMF - Nernst equation – Equilibrium constant from EMF Data - pH and EMF data - concentration cells with and without transference – Liquid junction potential and its determination - Activity and activity coefficients - Determination by EMF Method - Determination of solubility product from EMF measurements. Debye Huckel limiting law and its verification. Effect of dilution on equivalent conductance of electrolytes - Anomalous behaviour of strong electrolytes. Debye Huckel-Onsagar equation - verification and limitations, conductometric titrations.</p>	12
IV	<p>Chemical kinetics- Methods of deriving rate laws - complex reactions - Rate expressions for opposing, parallel and consecutive reactions involving unimolecular steps. Theories of reaction rates -collision theory - Steric factor - Activated complex theory - Thermodynamic aspects – Unimolecular reactions - Lindemann's theory - Lindemann-Hinshelwood theory. Reactions in solutions - Influence of solvent - Primary and secondary salt effects - Elementary account of linear free energy relationships - Hammett - Taft equation - Chain reactions - Rate laws of H_2-Br_2, photochemical reaction of $H_2 - Cl_2$, Decomposition of acetaldehyde and ethane - Rice-Herzfeld mechanism.</p>	12

V	Potentiometry: Advantages of potentiometric methods - Reference electrode - Standard hydrogen electrode .Acid- alkali or Neutralisation titration, Oxidation – reduction titrations, Precipitation titrations, complexometric titrations, Methods of end point location (Graphical, Differentiation method, Pinkhof- Treadwell method). Calomel electrode -Indicator electrodes: Metal-metal ion electrodes - Inert electrodes -Membrane electrodes - theory of glass membrane potential - Direct potentiometry, potentiometric titrations - Applications.	12
---	---	----

Reference Books:

1. Physical chemistry, G.K.Vemulapalli (Prentice Hall of India).
2. Physical chemistry, P.W.Atkins. ELBS
3. Chemical kinetics - K.J.Laidler, McGraw Hill Pub.
4. Text book of Physical Chemistry, Samuel Glasstone, Macmillan pub.
5. Polymer Sceince, Gowriker,Viswanadham, Sreedhar
7. Elements of Nuclear Science, H.J.Arniker, Wiley Eastern Limited.
8. Quantitative Analysis, A.I. Vogel, Addison Wesley Longmann Inc.
9. Physical Chemistry-G.W.Castellan, Narosa Publishing House, Prentice Hall
10. Physical Chemistry, W.J.Moore, Prentice Hall
11. Polymer Chemistry – Billmayer

Course Focus: Employability & Entrepreneurship.



A.G. & S.G. SIDDHARTHA DEGREE COLLEGE OF ARTS & SCIENCE

Vuyyuru-521165.
NAAC recredited at 'A' level
Autonomous -ISO 9001 – 2015 Certified

Title of the Paper: Practical – I – Inorganic Chemistry (20CH1L1)

Semester: I

S.No	COURSE OUTCOMES	PO'S
	After completion of the course, the student will be able to :	
1	Memorize the basic principles involved in quantitative and qualitative inorganic analysis.	1,7
2	Understand the importance of inorganic qualitative and quantitative analysis and their use in research and industry.	2,6
3	Apply the procedures of quantitative analysis and tests for identification of cations and anions in chosen field.	1,5
4	Evaluate how far these methods are accurate in quantitative determination.	1,4

List of experiments:

1. Preparation of Potassium trisoxalato ferrate (III).
2. Preparation of Tris thiourea copper (1) sulphate.
3. Preparation of Cis and trans potassium diaquodioxalato chromate (III).
4. Preparation of Hexa ammine cobalt (III) chloride.
5. Determination of Zn^{2+} with potassium ferro cyanide.
6. Determination of Mg^{2+} using EDTA.
7. Determination of Ni^{2+} using EDTA.
8. Determination of hardness of water using EDTA.
9. Gravimetric determination of nickel using dimethyl glyoxime.

10. Gravimetric determination of Zn using diammonium hydrogen phosphate.

11. Semi micro qualitative analysis of six radical mixtures

(One interfering anion and one less familiar cation for each mixture)

(minimum three mixtures).

Anions: S^{2-} , SO_3^{2-} , Cl^- , Br^- , I^- , NO_3^- , SO_4^{2-} , CH_3COO^- , $C_2O_4^{2-}$, $C_4H_4O_6^{2-}$, PO_4^{3-} , CrO_4^{2-} ,
 BO_3^{3-}

Cations: Ammonium (NH_4^+)

1st group: Ag^+ , Pb^{+2} , W^{+6}

2nd group: Pb^{+2} , Bi^{+3} , Cu^{+2} , Cd^{+2} , Sn^{+2} , Sn^{+4} , Mo^{+6} .

3rd group: Fe^{+2} , Fe^{+3} , Al^{+3} , Cr^{+3} , Ce^{+4} , Th^{+4} , Zr^{+4} , VO^{+2} , Be^{+2} .

4th group: Zn^{+2} , Mn^{+2} , Co^{+2} , Ni^{+2} .

5th group: Ca^{+2} , Ba^{+2} , Sr^{+2} .

6th group: Mg^{+2} , K^+ , Li^+ .



A.G. & S.G. SIDDHARTHA DEGREE COLLEGE OF ARTS & SCIENCE

Vuyyuru-521165.
NAAC recredited at 'A' level
Autonomous -ISO 9001 – 2015 Certified

Title of the Paper: Organic Chemistry (20CH1L2)

Semester: I

S.No	COURSE OUTCOMES	PO'S
	After completion of the course, the student will be able to :	
1	Understand the importance of organic compound synthesis and separation and their research and industry.	2,5,6
2	Understand the mechanisms for the synthesis of organic compounds in different steps.	1,7
3	Apply the procedure of synthesis and separation of organic compounds in required field.	1,5,7
4	Interpret the role of separation of organic compounds and synthesis in the core areas of research.	1,5,6

List of experiments:

1. Separation of Binary mixtures of Carboxylic acid + Neutral organic compounds (Solvent extraction method).
2. Separation of Binary mixtures of Basic nature + Neutral organic compounds (Solvent Extraction method).
3. Separation of Binary mixtures of Phenolic compounds + Neutral organic compounds (Solvent extraction method).
4. Preparation of Phthalimide from Phthalic anhydride – High Temperature.
5. Preparation of p-nitro acetanilide – Low temperature.
6. Preparation of Iodoform – Room temperature.

7. Paper chromatography - separate the given mixture of sugars.
8. Paper chromatography - separate the given mixture of amino acids.
9. Thin layer chromatography - separate the given mixture of phenols
10. Thin layer chromatography - separate the given mixture of 2,4-DNP derivatives of carbonyls compounds.

Text books/ Reference books:

1. A.I. Vogel, "A Text Book of Practical Organic Chemistry", Longman
2. A.I. Vogel, "Elementary Practical Organic Chemistry", Longman
3. F.G. Mann and B.C. Saunders, "Practical Organic Chemistry", Longman
4. Reaction and Synthesis in Organic Laboratory, B.S. Furniss, A.J. Hannaford, Tatchell, University Science Books mills valley.
5. Purification of Laboratory chemicals, manual, W.L.F. Armarego EDD Perrin
6. Reaction and Synthesis in Organic Chemistry Laboratory, Lutz-Friedjan- Tietze, Theophil Eicher, University Science Book.



A.G. & S.G. SIDDHARTHA DEGREE COLLEGE OF ARTS & SCIENCE

Vuyyuru-521165.
NAAC reaccredited at 'A' level
Autonomous -ISO 9001 – 2015 Certified

M.Sc. DEGREE EXAMINATION

FIRST SEMESTER

Paper-I :: General Chemistry - I

Time: 3 hours

Maximum Marks: 70

SECTION – A

Answer all the questions. Each question carries 2 marks. (10x2=20M)

1. Discuss the role of control charts in large scale production. (CO-2)
2. What are the measures of accuracy? (CO-1)
3. Explain the terms primary & secondary standards in titrimetric analysis. (CO-2)
4. Enumerate the significance of mixed indicators. (CO-2)
5. Give an account on classification of molecules in microwave spectroscopy. (CO-2)
6. Write a short note on degrees of freedom. (CO-2)
7. What are hot bands? (CO-1)
8. Define zero point energy and discuss its significance. (CO-2)
9. List out the possible symmetry elements and write the point group of the molecule HCHO. (CO-3)
10. Define a class. Explain with an example. (CO-2)

SECTION – B

(10x5=50M)

UNIT - I

11. a) Write notes on determinate errors. (CO-2)
(Or)
- b)(i) What are the criteria for rejection of an observation? (CO-2)
- (ii) Write notes on significant figures and computational rules. (CO-2)

UNIT – II

12. a) Explain the theory of neutralization indicators. (CO-2)

(Or)

b) Describe the Volhard & Mohr method in precipitation titrations. (CO-2)

UNIT – III

13. a) Explain the electromagnetic spectrum and discuss the interaction of electromagnetic radiation with matter. (CO-2)

(Or)

b) Discuss the applications of microwave spectroscopy. (CO-3)

UNIT - IV

14.a) Elaborate the formation of PQR branches in vibrational rotational spectrum.(CO-3)

(Or)

b) What is Born – oppenheimer approximation? How a break down in approximation occurs? (CO-2)

UNIT - V

15.a) Enumerate the role of group theory in IR & Raman spectroscopy. (CO-3)

(Or)

b) Explain the construction of C_{2V} character table. (CO-2)

M.Sc. DEGREE EXAMINATION

FIRST SEMESTER

Paper-II :: Inorganic Chemistry - I

Time: 3 hours

Maximum Marks: 70

SECTION – A

Answer all the questions. Each question carries 2 marks. (10x2=20M)

1. Explain the significance of approximation methods. (CO - 2)
2. Define operator. Explain the significance of operators in quantum mechanics. (CO - 2)
3. Discuss about Intercalation compounds. (CO - 1)
4. Enumerate the significance of natural oxygen carriers. (CO - 2)
5. Explain the role of VSEPR theory in predicting the geometry of molecule. (CO - 2)
6. Give an account on important features of MO theory. (CO - 2)
7. Explain the splitting of d-orbitals in square pyramidal crystal field. (CO - 2)
8. Discuss the drawbacks of valence bond theory. (CO - 1)
9. Derive a relation between stepwise and overall formation constants. (CO - 3)
10. What is chelate effect? Explain with an example. (CO - 2)

SECTION – B

(10x5=50M)

UNIT - I

11.a) Write down the wave equation for rigid rotor and solve it to get eigen functions. (CO-3)

(Or)

b) Arrive at the expression for first order correction of eigen values in perturbation method. (CO - 3)

UNIT – II

12. a) Write an account on phosphorus-nitrogen cyclic compounds. (CO - 2)

(Or)

b) Explain the structure and bonding in nitrosyl complexes. (CO - 2)

UNIT – III

13. a) Draw and explain the molecular orbital energy level diagram for BeH_2 molecule. (CO-3)

(Or)

b) Explain the evidences for $p\pi - d\pi$ bonding in non-transition metal compounds. (CO-4)

UNIT - IV

14. a) Discuss tetragonal distortion in an octahedral complex with a suitable example. (CO - 3)

(Or)

b) Why CN^- and CO cause greater crystal field splitting and I^- and Br^- cause lesser

crystal field splitting? Explain.

(CO - 4)

UNIT - V

15. a) Describe the spectrophotometric method for the determination of stability

Constant.

(CO - 3)

(Or)

b) Give a detailed account on HSAB theory.

(CO - 2)

M.Sc. DEGREE EXAMINATION

FIRST SEMESTER

Paper-III :: Organic Chemistry - I

Time: 3 hours

Maximum Marks: 70

SECTION – A

Answer all the questions. Each question carries 2 marks. (10x2=20M)

1. Explain anti aromaticity with example. (CO - 1)
2. Explain cross conjugation with example. (CO - 2)
3. Explain the structure of nitrenes. (CO - 1)
4. Discuss the structure of carbenes (CO - 1)
5. Discuss cram's rule with suitable examples. (CO - 2)
6. Write notes on epoxidation. (CO - 2)
7. Define Hoffmann's rule. Give suitable examples. (CO - 2)
8. Discuss syn elimination versus anti elimination. (CO - 2)
9. Give mechanism of Von-Richter rearrangement. (CO - 2)
10. Write noters on S_Ni mechanism. (CO - 1)

SECTION – B

(10x5=50M)

UNIT - I

11. a) Define delocalized chemical bonding. What are different types of delocalized chemical bonding. (CO - 2)

(Or)

- b) Explain the following terms (i) Cross Conjugation (ii)Hyper Conjugation. (CO - 2)

UNIT - II

12. a) Discuss the generation, stability and reactivity of carbocations. (CO - 3)

(Or)

- b) Explain synthesis and few reactions of the following

- (i) Free radicals (ii) Carbanions (CO - 2)

UNIT - III

13. a) Give an account of the addition of the following to carbon carbon multiple bonds (i) HX (ii) HOX (CO - 2)

(Or)

- b) Discuss in detail about the following
(i) Syn and Anti hydroxylation (ii) Hydrogenation (CO - 1)

UNIT – IV

14. a) Discuss pyrolytic eliminations and its orientation. (CO - 1)

(Or)

- b) Write a detailed account of E1CB mechanism. (CO - 1)

UNIT – V

15. a) What is anchimeric assistance. Discuss neighbouring group participation by σ and π bonds. (CO - 2)

(Or)

- b) Explain the following (i) Benzyne mechanism (ii) SN^{Ar} mechanism. (CO - 2)

M.Sc. DEGREE EXAMINATION

FIRST SEMESTER

Paper-IV :: Physical Chemistry - I

Time: 3 hours

Maximum Marks: 70

SECTION – A

Answer all the questions. Each question carries 2 marks. **(10x2=20M)**

1. Explain the second law of thermodynamics. (CO-2)
2. Write the Gibbs Duham equation and describe all the terms present. (CO-2)
3. Discuss briefly the surface active agents. (CO-2)
4. Explain the microemulsions in brief. (CO-2)
5. Write the nernst equation and describe all the terms present in it. (CO-2)
6. Explain the principle in conductometric titrations. (CO-2)
7. Write the mechanism in Lindemann's theory of unimolecular reactions. (CO-2)
8. Describe the mechanism in decomposition of Acetaldehyde. (CO-3)
9. Describe the advantages of potentiometric methods over classical methods. (CO-3)
10. Explain the calomel electrode in short. (CO-2)

SECTION – B

(10x5=50M)

UNIT - I

- 11.a) Derive the Maxwell's thermodynamic relations. (CO-3)

(Or)

- b) What is fugacity? Give its physical significance. Describe the different methods of determination of fugacity. (CO-3)

UNIT - II

- 12.a) Discuss the theory involved in ESCA. How are these techniques used in the analysis of surfaces? (CO-2)

(Or)

- b) What is CMC? How is it determined? What are the factors affecting CMC? (CO-2)

UNIT - III

13.a)What is activity? How is activity coefficient determined from EMF? (CO-2)

(Or)

b)What is the effect of dilution on equivalent conductance of electrolytes?

(CO-2)

UNIT – IV

14.a)Discuss the kinetics of consecutive reactions. (CO-2)

(Or)

b)Discuss the kinetics of $H_2 - Br_2$ reaction in detail.

(CO-3)

UNIT - V

15.a) Explain the theory of precipitation titrations in detail. (CO-2)

(Or)

b) Discuss the potentiometric titrations in detail.

(CO-2)

A.G.& S.G.SIDDHARTHA DEGREE COLLEGE OF ARTS & SCIENCE

DEPARTMENT OF CHEMISTRY

M.Sc – CHEMISTRY (ORGANIC CHEMISTRY)

CIA Practicals

Total Marks – 30 M

M.Sc. DEGREE EXAMINATION

External Practical Model Paper

Time: 6 hours

Maximum Marks: 70

1. To write the principle and procedure / mechanism related to practical as listed in the practical syllabus – 5 M

2. Record – 10 M

3. Experiment (Procedure / Tabulation / calculation etc.,) – 50 M

4. Result / Graphs / Yield / Report – 5 M

A.G. & S.G.SIDDHARTHA DEGREE COLLEGE OF ARTS & SCIENCE
(Autonomous)
DEPARTMENT OF CHEMISTRY
M.Sc – CHEMISTRY (ORGANIC CHEMISTRY)

Appendix - I

Scheme of Instruction and Evaluation for **M.Sc. (Organic Chemistry)** programme
for the batch of students admitted during 2020 – 2021

Semester – III

Paper	Title of the Paper	Instruction Hours Per Week			Credits(T+P)	Evaluation		
		L	T	P		CIA MARKS	SEE	
							MARKS	DURATION
Paper-I	Advanced Organic Spectroscopy	4	1	--	4	30	70	3 hours
Paper-II	Organic Reactions & Mechanisms	4	1	--	4	30	70	3 hours
Paper-III	Organic Synthesis	4	1	--	4	30	70	3 hours
Paper-IV	Chemistry of Natural Products	4	1	--	4	30	70	3 hours
Paper-V	Open Elective- (Polymer Chemistry)	4	--	--	4			
Pract-I	Organic Preparations	--	--	6	3	30	70	6 hours
Pract-II	Mixture Analysis	--	--	6	3	30	70	6 hours
	Sub-Total	20	4	12	20+4+12=36			



A.G. & S.G. SIDDHARTHA DEGREE COLLEGE OF ARTS & SCIENCE

Vuyyuru- 521165.

NAAC recredited at 'A' level

Autonomous -ISO 9001 – 2015 Certified

Title of the Paper: ADVANCED ORGANIC SPECTROSCOPY

Semester: III

Course Code	20CH3T1	Course Delivery Method	Class Room / Blended Mode - Both
Credits	4	CIA Marks	30
No. of Lecture Hours / Week	4	Semester End Exam Marks	70
Total Number of Lecture Hours	60	Total Marks	100
Year of Introduction :2020-21	Year of Offering: 2021 - 22	Year of Revision: ----	Percentage of Revision: 0%

Course Objective: The main objective of this paper is to give a basic and updated knowledge for the students on Proton & ^{13}C NMR Spectroscopy, Structural Elucidation of Organic compounds Using UV, IR, ^1H -NMR, ^{13}C -NMR, 2D NMR spectroscopy and Optical Rotatory Dispersion (ORD) & CD spectroscopy.

Course Outcomes:-

CO1: Summarize the principle, theory and advanced aspects of ^1H NMR, ^{13}C NMR, 2D NMR, ORD & CD spectroscopic techniques.

CO2: Display the knowledge gained in the areas of ^1H NMR, ^{13}C NMR, 2D NMR, ORD & CD Spectroscopic techniques in chosen job role.

CO3: Interpret the spectral data of ^1H NMR, ^{13}C NMR, 2D NMR, ORD & CD in elucidating the Structure of the molecule.

CO4: Assess that how far the spectral data of ^1H NMR, ^{13}C NMR, 2D NMR, ORD & CD are useful in establishing the structure of the molecule.

Syllabus

Course Details:-

Unit	Learning Units	Lecture Hours
I	Proton NMR Spectroscopy: Determination of structure of organic compounds using PMR data. Spin system, Nomenclature of spin system, spin system of simple and complex PMR spectrum (Study of AB – A ₂ – AB ₂ . ABX – ABC – AMX interactions) Simplification of complex spectra- nuclear magnetic double resonance, chemical shift reagents, solvent effects on PMR Spectrum . Nuclear Overhauser Effect (NOE).	12
II	¹³C-NMR spectroscopy: Similarities and Difference between PMR and CMR-CMR recording techniques -BBC-BBD-SFORD-Gate pulse CMR spectrum. General considerations, chemical shift (aliphatic, olefinic, alkyne, aromatic, heteroaromatic and carbonylcarbon), coupling constants. Typical examples of CMR spectroscopy – simple problems.	12
III	ORD & CD Curves: Optical rotatory dispersion : Theory of optical rotatory dispersion – Cotton effect – CD curves-types of ORD and CD curves-similarities and difference between ORD and CD curves. α- Halo keto rule, Octant rule – application in structural studies.	12
IV	2D NMR spectroscopy: Definitions and importance of COSY, DEPT, HOMCOR, HETCOR, INADEQUATE, INDOR, INEPT, NOESY, HOM2DJ, HET2DJ. Study of COSY, DEPT, HOMCOR, HETCOR, INADEQUATE, INDOR, INEPT, NOESY, HOM2DJ, HET2DJ, taking simple organic compounds as examples.	12
V	Structural Elucidation of Organic compounds Using UV, IR, ¹ H-NMR, ¹³ C-NMR and Mass spectroscopy.	12

Reference Books:

1. Introduction to Spectroscopy – D. L. Pavia, G.M. Lampman, G. S. Kriz, 3rd Ed. (Harcourt College publishers).
2. Spectrometric identification of organic compounds R. M. Silverstein, F. X. Webster, 6th Ed. John Wiley and Sons.
3. Spectroscopic methods in organic chemistry - D. H. Williams and I Flemming McGraw Hill, 4th edition.
4. Absorption spectroscopy of organic molecules – V. M. Parikh
5. Organic structural Spectroscopy- Joseph B. Lambert, Shurvell, Lightner, Cooks, Prentice-Hall (1998).
6. Organic structures from spectra – Field L.D., Kalman J.R. and Sternhell S. 4th Ed. John Wiley and sons Ltd.
7. Organic spectroscopy – Principle & Applications – Jag Mohan, Narosa, 2nd edition, Publishing house.

Course Focus: Employability & Entrepreneurship.



A.G. & S.G. SIDDHARTHA DEGREE COLLEGE OF ARTS & SCIENCE

Vuyyuru-521165.

NAAC reaccredited at 'A' level

Autonomous -ISO 9001 – 2015 Certified

Title of the Paper: ORGANIC REACTIONS & MECHANISMS

Semester: III

Course Code	20CH3T2	Course Delivery Method	Class Room / Blended Mode - Both
Credits	4	CIA Marks	30
No. of Lecture Hours / Week	4	Semester End Exam Marks	70
Total Number of Lecture Hours	60	Total Marks	100
Year of Introduction :2020-21	Year of Offering: 2021 - 22	Year of Revision: -----	Percentage of Revision: 0

Course Objective: The main objective of this paper is to give a basic and updated knowledge for the students on Oxidations, Reductions, Molecular Rearrangements, Pericyclic Reactions and Organic Photo Chemistry.

Course Outcomes:-

- CO1 :** Acquire sound knowledge of oxidations, reductions, molecular rearrangements, pericyclic reactions and photo chemistry.
- CO2 :** Understand the concepts involved in oxidations, reductions, molecular rearrangements, pericyclic reactions and photo chemistry.
- CO3 :** Apply the conceptual knowledge gained in oxidations, reductions, molecular rearrangements, pericyclic reactions and photo chemistry in chosen fields.
- CO4 :** Analyse and categorise the various types oxidations, reductions, molecular rearrangements, pericyclic reactions and photo chemistry in a given reactions.

Syllabus

Course Details

Unit	Learning Units	Lecture Hours
I	Oxidations Definition and types of Oxidations, oxidations with ruthenium tetroxide, NBS, iodobenzene diacetate, Ti(III) nitrate, Chromium (VI) oxidants, Lead tetra acetate, SeO ₂ , MnO ₂ , Ag ₂ CO ₃ , Oppenauer oxidation, perhydroxylation using KMnO ₄ , OsO ₄ , HIO ₄ , oxidation with iodine silver carboxylate (Woodward and Prevost conditions), Definition & mechanism of epoxidation by peracids.	12

II	<p>Reductions</p> <p>Definition and types of reductions, reduction by dissolving metals - Reduction with metal and liquid ammonia (Birch Reduction of aromatic compounds), Reduction with metal acid - Clemensons reduction, Reduction by hydride transfer reagents, Aluminium alkoxide - Meerwein Ponderf Verley Reduction, LiAlH_4, NaBH_4, Diisobutylaluminium hydride(DIBAL), Sodium cyano borohydride, trialkyl borohydrides, Reduction with diimide,. Wolff-Kishner reduction.</p>	12
III	<p>Molecular Rearrangements</p> <p>Migration to electron deficient carbon atom. Pinacole-Pinacolone rearrangement, Wagner-Meerwein rearrangement, Dienone-Phenol rearrangement, Benzil-Benzilic acid rearrangement, Favorski rearrangement, ARNDT Eistert rearrangement, Sommelet – Hauser rearrangement.</p> <p>Migration to electron deficient hetero atom: Wolf, Hofmann, Curtius, Lossen, Schmidt, Beckmann rearrangement, Baeyer-Villiger rearrangement, Stevens, Neber rearrangements. Fries, Fischer-Hepp, Orton, Bamberger, Dakin, Cumene Hydroperoxide rearrangement.</p>	12
IV	<p>Pericyclic Reactions – I:</p> <p>Definition, classification of pericyclic reactions, Molecular Orbital energy level diagrams, electronic configuration in ground and first excited states of Ethylene, 1,3-Butadiene, 1,3,5 – Hexatriene, allyl system, stereo chemical notations – suprafacial, antarafacial, conrotatory and disrotatory modes, Woodward and Hoffmann selection rules.</p> <p>Electrocyclic reactions: Mechanism, Stereochemistry of $(4n)$ and $(4n+2)$ π systems. PMO, FMO and correlation methods.</p> <p>Cyclo additions: Mechanism, stereochemistry of $(2+2)$ and $(4+2)$ π systems, PMO, FMO and correlation methods.</p> <p>Sigmatropic rearrangements: Classification, mechanism for FMO and PMO approach under thermal and photo chemical conditions. (Detailed treatment of Claisen, Cope rearrangements fluxional molecules, aza-cope rearrangements).</p>	12
V	<p>Photochemistry:</p> <p>Photochemical processes: Energy transfer, sensitization and quenching. Singlet and triplet states and their reactivity. Photochemistry of olefins – conjugated olefins, Aromatic compounds–isomerisation–additions. Photochemistry of carbonyl compounds – Norrish type I and II reactions –Paterno – Buchi Reaction.</p> <p>Photoreduction, Photochemical rearrangements–Photo Fries rearrangement, Di-π-methane rearrangement, Barton reaction.</p>	12

Reference Books:

1. Molecular reactions and Photochemistry by Charles Dupey and O. Chapman, Prentice Hall.
2. Reaction mechanism in organic chemistry. 3rd edition, S.M.Mukherji & Singh.
3. Advanced Organic Chemistry-Reactions, Mechanisms and Structure, Jerry March, John Wiley and sons, 6th edition.
4. Advanced Organic Chemistry, F.A. Carey and R.J Sundberg, Plenum.
5. Modern methods of organic synthesis, Cambridge University press, 3rd edition, W.Carruthers.
6. Organic Reaction Mechanisms, V.K.Ahluwalia, 4th edition, Narosa.
7. Reactions, rearrangements and reagents.S.N.Sanyal,4th edition.
8. Organic Photo chemistry and Pericyclic reactions' M.G.Arora Anmol Publications Pvt. Ltd.
9. Fundamentals of Photochemistry by K.K.Rohatgi–Mukherjee New Age international publishers.

Course Focus: Employability & Entrepreneurship.



A.G. & S.G. SIDDHARTHA DEGREE COLLEGE OF ARTS & SCIENCE

Vuyyuru-521165.

NAAC reaccruited at 'A' level

Autonomous -ISO 9001 – 2015 Certified

Title of the Paper: ORGANIC SYNTHESIS

Semester: III

Course Code	20CH3T3A	Course Delivery Method	Class Room / Blended Mode - Both
Credits	4	CIA Marks	30
No. of Lecture Hours / Week	4	Semester End Exam Marks	70
Total Number of Lecture Hours	60	Total Marks	100
Year of Introduction :2020-21	Year of Offering: 2021 - 22	Year of Revision: -----	Percentage of Revision: 0%

Course Objective: The main objective of this paper is to give a basic and updated knowledge for the students on Formation of C-C single & double bonds, Diels-Alder and related reactions, Retro Synthetic Analysis and Protecting Groups.

Course Outcomes:

- CO1 :** Memorize the concepts, principles and theories related to formation of C – C single bond, C – C double bond, Diel's Alder related reactions. Protecting groups and disconnection approach in organic synthesis.
- CO2 :** Understand the role and significance of formation of C – C single bond, C – C double bond, Diel's Alder related reactions. Protecting groups and disconnection approach in organic synthesis.
- CO3 :** Apply the conceptual knowledge gained in formation of C – C single bond, C – C double bond, Diel's Alder related reactions. Protecting groups and disconnection approach in organic synthesis as and when required.
- CO4 :** Analyze the role of various reagents in carrying out the organic reactions like formation of C – C single bond, C – C double bond, Diel's Alder related reactions. Protecting groups and disconnection approach in organic synthesis.

Syllabus

Course Details

Unit	Learning Units	Lecture Hours
I	Formation of carbon-carbon single bonds: Alkylation of relatively acidic methylene groups, alkylation of ketones, enamine and related reactions, umplong (dipole inversion). Allylic alkylation of alkenes, alkylation of α -thiocarbanions- α -selenocarbanions, formation of carbon carbon single bonds by the addition of free radicals to alkenes, synthetic applications of carbenes and carbenoids.	12

II	<p>Formation of carbon-carbon double bonds</p> <p>Pyrolytic syn elimination reactions sulphoxide-sulphonate rearrangement, synthesis of allyl alcohols, the witting reaction, alkenes from sulphones, decarboxylation of β-lactones, alkenes from aryl sulphonyl hydrazones.</p> <p>Stereo selective synthesis of tri and tetra substituted alkenes, oxidative decarboxylation of carboxylic acids, stereospecific synthesis from 1,2-diols, reductive dimerization of carbonyl compounds.</p>	12
III	<p>Diels-Alder and related reactions: The dienophile, heterodienophile, oxygen as dienophile, The diene, acyclic dienes, heterodienes, 1,2-dimethylene cycloalkanes, vinyl cycloalkenes, and vinyl arenes, cyclic dienes and furans.</p> <p>Intra molecular Diels –Alder reactions, stereochemistry and mechanism of Diels – Alder reaction, retro Diels – Alder reaction, catalysis by lewis acids, photosensitized Diels- Alder reactions and 1,3-dipolar cycloaddition reactions, the ene reaction.</p>	12
IV	<p>Disconnection approach</p> <p>Introduction to Retro-synthetic analysis, Disconnection approach with suitable examples, Definitions: FGI, Disconnection, synthons, synthetic equivalent, reagent, target molecule, General strategy: choosing a disconnection, greatest simplification, symmetry, high yielding steps, recognizable starting materials.</p> <p>Chemo, regio and stereo selectivity with examples. One group C-C disconnections-Alcohols, carbonyl compounds, alkene synthesis, two group disconnections: 1,3 – dicarbonyl compounds, α,β – unsaturated carbonyl compounds.</p>	12
V	<p>Protecting groups:</p> <p>Theory and importance of functional group protection and deprotection in organic synthesis:-Protecting agents for the protection of functional groups: Hydroxyl group, Amino group, Carbonyl group and Carboxylic acid group</p> <p>carbon-carbon multiple bonds; chemo- and regioselective protection and deprotection. Illustration of protection and deprotection in organic synthesis.</p>	12

Reference Books:

1. Modern methods of Organic synthesis , W. Carruthers Cambridge Press (3rd edition)
2. Principles of Organic synthesis by, ROC Norman, 3rd edition, CRC press.
3. Modern Method of Organic Synthesis ,Carruthers and Coldham Sachinkumar Ghosh, Cambridge New Central Book Agency,1st edition.
4. Advances in Organic Reaction mechanism and structure, J. March, 6th edition, McGrew Hill
5. Organic Synthesis: Ratna kumar kar, vol – II, NCBA Publications.

Course Focus: Employability & Entrepreneurship.



A.G. & S.G. SIDDHARTHA DEGREE COLLEGE OF ARTS & SCIENCE

Vuyyuru-521165.

NAAC recredited at 'A' level

Autonomous -ISO 9001 – 2015 Certified

Title of the Paper: CHEMISTRY OF NATURAL PRODUCTS

Semester: III

Course Code	20CH3T4B	Course Delivery Method	Class Room / Blended Mode - Both
Credits	4	CIA Marks	30
No. of Lecture Hours / Week	4	Semester End Exam Marks	70
Total Number of Lecture Hours	60	Total Marks	100
Year of Introduction : 2020-2021	Year of Offering: 2021 - 22	Year of Revision: -----	Percentage of Revision: 0%

Course Objective: The main objective of this paper is to give a basic and updated knowledge for the students on Alkaloids, Terpenoids, Steroids, Flavonoids, Isoflavonoids and Plant pigments.

Course Outcomes:-

CO1 : Memorize the concepts related to Alkaloids, Terpenoids, Steroids, Flavonoids and Isoflavonoids and Pigments.

CO2 : Understand the chemical role of Alkaloids, Terpenoids, Steroids, Flavonoids and Isoflavonoids and Pigments.

CO3 : Execute the conceptual knowledge gained in the areas of Alkaloids, Terpenoids, Steroids, Flavonoids and Isoflavonoids and Pigments.

CO4 : Analyze the role of methods involved in structure elucidation of Alkaloids, Terpenoids, Steroids, Flavonoids and Isoflavonoids and Pigments.

Syllabus

Course Details

Unit	Learning Units	Lecture Hours
I	Alkaloids: Introduction, Definition, occurrence, role of alkaloids in plants, classification, isolation and general methods for structural elucidation of alkaloids. Structure elucidation of Morphine, Quinine.	12
II	Terpenoids: Introduction, Definition, nomenclature, classification, isolation, isoprene rule and general methods for structural elucidation of Terpenoids. Structure elucidation of Zingiberene, , farnesol.	12
III	Steroids: Introduction, Definition, nomenclature, classification. Occurrence, isolation, physiological action, structure elucidation of Androsterone, Progesterone.	12
IV	Flavonoids and Isoflavonoids: Introduction, Definition, classification, isolation, physiological action, structure elucidation of Kaempferol and Quercetin.	12
V	Pigments: Introduction, classification of natural pigments, introduction and classification of carotenoids, functions of carotenoids in plants and animals, structure and synthesis of α – carotene and β – carotene.	12

Reference Books:

1. Organic Chemistry, Vol:2, I.L.Finar, 5th Edition.
2. Chemistry of Natural Products, K.W.Bentley, Oxford AT the clarendon press, 1st edition.
3. Chemistry of Natural products by P.S.Kalsi Kalyani Publishers. 1983, low cost university edition.
4. Chemistry and physiology of alkaloids by Manske Vol.I & II, VII, Academic press Inc., publishers Newyork, 1st edition.

Course Focus: Employability & Entrepreneurship.



A.G. & S.G. SIDDHARTHA DEGREE COLLEGE OF ARTS & SCIENCE

Vuyyuru-521165

NAAC reaccredited at 'A' level
Autonomous -ISO 9001 – 2015 Certified

Title of the Paper: POLYMER CHEMISTRY

Semester: III

Course Code	200ECH	Course Delivery Method	Class Room / Blended Mode - Both
Credits	4	CIA Marks	30
No. of Lecture Hours / Week	4	Semester End Exam Marks	70
Total Number of Lecture Hours	60	Total Marks	100
Year of Introduction : 2021 - 22	Year of Offering: 2021 - 22	Year of Revision: ----	Percentage of Revision: ----

Course Objective: The main objective of this paper is to give a basic and updated knowledge for the students on Polymer chemistry.

Course Outcomes:

CO1 : Memorize the concepts related to polymer chemistry

CO2 : Understand the concepts of polymer chemistry

CO3 : Apply the knowledge gained in polymer chemistry in chosen job role.

Syllabus

Course Details

Unit	Learning Units	Lecture Hours
I	Introduction, Classification of polymers, Polymerization, chain polymerization, step polymerization, Co polymerization, Free radical chain polymerization, cationic polymerization, anionic polymerization, Polymerization Techniques, Graft and Block Copolymers.	12
II	Polymer Synthesis, Isolation and Purification of polymers, Polymer Fractionation, Molecular weight determination, Molecular weight determination curve, Processing Techniques.	12
III	Polymer Reactions—Introduction, Hydrolysis, Acidolysis, Aminolysis, Hydrogenation, Addition and Substitution Reactions, Cyclisation reactions, Cross-linking Reactions.	12

IV	Polymer Degradation – Definition, Types of Degradation, Thermal Degradation, Mechanical Degradation, Degradation by Ultrasonic Waves, Photodegradation, Degradation by High-Energy Radiation, Oxidative Degradation, Hydrolytic Degradation.	12
V	Plastics, Fibres, Elastomers-Polyethylene, Polystyrene, PolyEsters, PolyAcrylonitrile, Polyurethanes, Polyvinyl Chloride, Polyisoprenes. Resins–Phenol Formaldehyde Resin, Urea Formaldehyde and Melamine–Formaldehyde Resins,Epoxy Polymers, Silicon Polymers.	12

Reference Books:

1. Textbook of Polymer Science by Frod,W.Billmayer,
2. An Introduction to Polymer Chemistry by Moore.
3. Polymer Chemistry-An Introduction by M.P.Stevens.
4. Polymer Science –VRGowariker, NVViswanathan, JayadevSreedhar.

Course Focus : Employability .



A.G. & S.G. SIDDHARTHA DEGREE COLLEGE OF ARTS & SCIENCE

Vuyyuru-521165.

NAAC reaccredited at 'A' level

Autonomous -ISO 9001 – 2015 Certified

Title of the Paper: ORGANIC PREPARATIONS

Semester: III

Course Code	20CH3L1	Course Delivery Method	Class Room / Blended Mode - Both
Credits	4	CIA Marks	30
No. of Lecture Hours / Week	4	Semester End Exam Marks	70
Total Number of Lecture Hours	60	Total Marks	100
Year of Introduction :2020-21	Year of Offering: 2021 - 22	Year of Revision: -----	Percentage of Revision: 0%

Course Objective: The main objective of this paper is to give a basic and updated knowledge for the students on organic chemistry practical.

Course Outcomes:-

- CO1:** Memorize the principle involved in various organic preparations.
- CO2:** Understand the mechanism involved in organic preparation.
- CO3:** Apply the knowledge of organic preparations in their chosen field.

Syllabus

Course Details:-

1. Preparation of organic compounds: Three stage preparations by reactions involving nitration, halogenation, oxidation, reduction, alkylation, acylation, condensation and rearrangement. (A student is expected to prepare at least five different organic compounds by making use of the reactions given above).
2. Green Procedures for organic compound preparations (atleast 5 preparations).

Course Focus: Skill Development & Employability



A.G. & S.G. SIDDHARTHA DEGREE COLLEGE OF ARTS & SCIENCE

Vuyyuru- 521165.
NAAC reaccredited at 'A' level
Autonomous -ISO 9001 – 2015 Certified

Title of the Paper: Mixture Analysis

Semester: III

Course Code	20CH3L2	Course Delivery Method	Class Room / Blended Mode - Both
Credits	4	CIA Marks	30
No. of Lecture Hours / Week	4	Semester End Exam Marks	70
Total Number of Lecture Hours	60	Total Marks	100
Year of Introduction :2020-21	Year of Offering: 2021 - 22	Year of Revision: -----	Percentage of Revision: 0 %

Course Objective: The main objective of this paper is to give a basic and updated knowledge for the students on Analysis of organic binary mixtures.

Course Outcomes:-

CO1 : Get familiarized with the tests involved to identification of various functional groups.

CO2 : Understand the theory involved in identification and separation of the given organic mixture based on the solubility

CO3 : Apply the knowledge to identify various functional groups present in the given organic compound by using a systematic procedure.

Syllabus

Course Details:-

Analysis of organic binary mixtures: Separation and identification of organic binary mixtures (The students must be given training in at least 10 mixtures with different functional groups).

Note: For semester end examinations the student has to submit at least two solid derivatives for each individual component.

Course Focus: Skill Development & Employability

**M.Sc. DEGREE EXAMINATION
THIRD SEMESTER
Paper-I:: ADVANCED ORGANIC SPECTROSCOPY**

Time: 3 hours

Maximum Marks: 70

SECTION – A

Answer all the questions. Each question carries 2 marks. (10x2M=20M)

1. a) Explain the importance of Double irradiation. (CO-1)
- b) Write a short note on nomenclature of spin systems. (CO-1)
- c) Explain the α , β & γ effects in ^{13}C NMR with suitable examples. (CO-1)
- d) Discuss the importance of off resonance decoupling CMR spectrum. (CO-1)
- e) What is Cotton effect? (CO-1)
- f) Predict the sign of cotton effect in 3-methyl cyclohexanone when substituent is in equatorial position. (CO-1)
- g) What information is possible from the COSY experiment? (CO-2)
- h) Discuss about various periods involved in 2D NMR. (CO-1)
- i) Discuss briefly the IR signals for the compound $\text{C}_6\text{H}_5 - \text{CH}_2 - \text{O} - \text{CO} - \text{CH}_3$. (CO-2)
- j) Predict the possible number of ^1H NMR signals for the compound $\text{CH}_3 - (\text{CO}) - \text{CH}_2 - \text{CH}_3$. (CO-2)

SECTION – B

(10x5=50M)

UNIT - I

2. a) Explain the effect of solvent on PMR spectrum. (CO-2)
- (Or)**
- b) Differentiate between first order and non first order PMR spectrums with examples. (CO-2)

UNIT – II

3. a) Discuss the importance of BBD & SFORD techniques in ^{13}C NMR spectroscopy. (CO-2)
- (Or)**
- b) A compound of MF C_4H_{10} in its CMR Spectrum show 17.1(q) 67.4(T). Determine the structure of compound by using CMR data. (CO-2)

UNIT – III

4. a) Explain the following i) Axial halo ketone rule ii) Types of optical rotatory dispersion curves. (CO-1)
- (Or)**
- b) Explain the applications of Octant rule. (CO-2)

UNIT – IV

5. a) What information about a compound can be obtained from the 2D INADEQUATE experiment? (CO-2)
- b) Discuss the importance of NOESY technique with suitable example. (CO-2)

UNIT – V

6. a) Deduce the structure of the compound consistent with the following data elemental analysis: C=32.14% H 5.35% and Cl 62.5% UV: No absorption above 210 nm, IR (CCl_4) 2941, 2265 and 1460 cm^{-1} PMR δ 2.72(septet, J=6.7, 1H), 1.33 (doublet, J=6.7, 6H) (CO-3)
- (Or)**
- b) Deduce the structure of the compound consistent with the following data elemental analysis: C=32.14% H 5.35% and Cl 62.5% UV: No absorption above 210 nm IR (CCl_4) 2940, 1265 and 690 cm^{-1} and PMR δ 3.5(2H,D), 3.3(1H,m) and 1.25(3H,d) (CO-3)

**M.Sc. DEGREE EXAMINATION
THIRD SEMESTER
Paper-II: ORGANIC REACTIONS & MECHANISMS**

Time: 3 hours

Maximum Marks: 70

SECTION – A

Answer all the questions. Each question carries 2 marks. (10x2M=20M)

1. a) Discuss oxidations with HIO_4 . (CO-2)
- b) Define oxidation and discuss the various types of oxidations. (CO-1)
- c) Write notes on reduction with diimide. (CO-1)
- d) Give the definition and mechanism of Clemmenson's reduction. (CO-2)
- e) Discuss Dienone phenol rearrangement. (CO-1)
- f) Write an account of Wolf rearrangement. (CO-2)
- g) What are pericyclic reactions? Give the classification. (CO-1)
- h) Write the molecular orbital energy level diagram for 1,3 – Butadiene. (CO-2)
- i) Write notes on energy transfer. (CO-1)
- j) Explain Barton reaction. (CO-2)

SECTION – B

(5x10M=50M)

UNIT - I

2. a) Explain oxidations with i) RuO_4 ii) SeO_2 (CO-3)
- (Or)**
- b) Explain oxidations with i) KMnO_4 ii) MnO_2 (CO-3)

UNIT – II

3. a) Discuss Birch reduction of aromatic compounds. (CO-2)
- (Or)**
- b) Discuss the reductions with LiAlH_4 . (CO-2)

UNIT – III

4. a) Explain the following
i) Wagner Meerwein rearrangement ii) Benzil – Benzilic acid rearrangement. (CO-2)
- (Or)**
- i) Baeyer Villiger rearrangement ii) Cumene hydroperoxide rearrangement. (CO-2)

UNIT - IV

5. a) Apply correlation method to $4n\pi$ electrocyclic reaction for thermal and photochemical conditions. (CO-3)
- (Or)**
- b) Apply FMO method to 1,5 sigmatropic shift and write Woodward and Hoffmann rules by PMO method. (CO-3)

UNIT - V

6. a) Discuss Norish type – I and type – II reactions. (CO-2)
- (Or)**
- b) Explain the following i) photochemistry of olefins ii) Di – π – methane rearrangement. (CO-2)

**M.Sc. DEGREE EXAMINATION
THIRD SEMESTER
Paper-III:: ORGANIC SYNTHESIS**

Time: 3 hours

Maximum Marks: 70

SECTION – A

Answer all the questions. Each question carries 2 marks. (10x2M=20M)

1. a) What are acidic methylene groups? (CO-2)
- b) Explain about carbenes. (CO-1)
- c) Discuss in short about syn elimination. (CO-1)
- d) Elaborate Wittig reaction with an example. (CO-2)
- e) Describe dienophile with an example. (CO-1)
- f) What are lewis acids? Explain with an example. (CO-2)
- g) Enumerate the significance of Disconnection approach in organic synthesis. (CO-2)
- h) Write a short note on synthon. (CO-1)
- i) Discuss the role of functional group protection & deprotection in organic synthesis. (CO-2)
- j) Explain the importance of regioselective protection. (CO-2)

SECTION – B

(5x10M=50M)

UNIT - I

2. a) Explain enamine and related reactions. (CO-2)
- (Or)**
- b) Discuss in detail the synthetic applications of carbenes and carbenoids with examples. (CO-2)

UNIT – II

3. a) Write an account of reductive dimerisation of carbonyl compounds with examples. (CO-2)
- (Or)**
- b) Discuss any three methods for the stereoselective synthesis of tri and tetra substituted alkenes. (CO-2)

UNIT – III

4. a) What is Diels Alder reaction? Discuss the mechanism and stereochemistry. (CO-2)
- (Or)**
- b) Write note on 1,3 – dipolar cycloaddition reactions. (CO-2)

UNIT - IV

5. a) Discuss the various methods of disconnection of alcohols. (CO-3)
- (Or)**
- b) Give an account of disconnections of 1,3 – dicarbonyl compounds. (CO-2)

UNIT – V

6. a) Discuss about the protecting agents to protect the following functional groups (CO-3)
 (i) AMINO group (ii) carboxylic acid.
- (Or)**
- b) List out the reagents and apply them for the protection and deprotection of hydroxyl and carbonyl groups. (CO-3)

**M.Sc. DEGREE EXAMINATION
THIRD SEMESTER
Paper-IV:: CHEMISTRY OF NATURAL PRODUCTS**

Time: 3 hours

Maximum Marks: 70

SECTION – A

Answer all the questions. Each question carries 2 marks. (10x2M=20M)

1. a) What are alkaloids? Explain. (CO-2)
- b) Discuss the general classification of alkaloids. (CO-1)
- c) Discuss Isoprene rule. (CO-1)
- d) Write the structure of Zingiberine. (CO-2)
- e) Write the synthesis of farnesol. (CO-2)
- f) Discuss the nomenclature of steroids. (CO-1)
- g) Give a short notes on classification of flavonoids? (CO-1)
- h) Discuss the isolation of flavonoids and isoflavonoids. (CO-2)
- i) Discuss the classification of natural pigments. (CO-1)
- j) Discuss the functions of carotenoids in plants. (CO-2)

SECTION – B

(10x5=50M)

UNIT - I

2. a) Outline the synthesis of Morphine. (CO-2)
- (Or)**
- b) Discuss the structure elucidation of Quinine. (CO-3)

UNIT – II

3. a) Explain the structure elucidation of santonin. (CO-2)
- (Or)**
- b) Write notes on structure elucidation of abietic acid. (CO-2)

UNIT – III

4. a) Establish the structure of nucleus and size of the rings A,B,C and D in cholesterol. (CO-3)
- (Or)**
- b) Establish the structure of progesterone and write any one method of synthesis. (CO-3)

UNIT - IV

5. a) Write structure elucidation of kaempferol. (CO-3)
- (Or)**
- b) Write structure elucidation of Quercetin. (CO-3)

UNIT - V

6. a) Discuss the structure elucidation of α – carotene. (CO-3)
- (Or)**
- b) Discuss the structure elucidation of β - carotene (CO-3)

**M.Sc. DEGREE EXAMINATION
THIRD SEMESTER
POLYMER CHEMISTRY**

Time: 3 hours

Maximum Marks: 70

SECTION – A

Answer all the questions. Each question carries 2 marks. (10x2M=20M)

1. a) Discuss about classification of polymers. (CO-1)
- b) Explain one polymerization reaction which involves free radical mechanism. (CO-2)
- c) Give a short account on isolation of polymers. (CO-1)
- d) Describe the purification method of polymers. (CO-1)
- e) What is hydrolysis? Explain with an example. (CO-2)
- f) What is cross – linking reaction? Explain its impact. (CO-2)
- g) List out the types of degradation methods. (CO-1)
- h) Explain ultrasonic waves degradation with an example. (CO-2)
- i) What are elastomers? Explain in brief. (CO-2)
- j) Discuss the method for the synthesis of polystyrene. (CO-2)

SECTION – B

(10x5=50M)

UNIT - I

2. a) Explain in detail about cationic polymerization with suitable examples. (CO-2)
- (Or)**
- b) Give a detailed account on Graft and Block copolymers. (CO-2)

UNIT – II

3. a) Discuss in detail about molecular weight determination. (CO-2)
- (Or)**
- b) Explain elaborately about various processing techniques. (CO-2)

UNIT – III

4. a) Illustrate the following with suitable examples (i) Aminolysis (ii) Cyclisation reactions. (CO-2)
- (Or)**
- b) Write an account on addition & substitution reactions with suitable examples. (CO-2)

UNIT – IV

5. a) Describe the following degradation methods with suitable examples
(i) Thermal degradation (ii) Photo degradation (CO-2)
- b) Discuss the significance of oxidative degradation and hydrolytic degradation. (CO-2)

UNIT – V

6. a) Give an account on the following (i) Polyacrylonitrile (ii) Polyurethanes (CO-2)
- (Or)**
- b) Elaborate the following in detail (i) Epoxy polymers (ii) Silicon polymers (CO-2)

**A.G &S.G.SIDDHARTHA DEGREE COLLEGE OF ARTS & SCIENCE ,
VUYYURU - 521165.**

**NAAC recredited at 'A' level
Autonomous -ISO 9001 – 2015 Certified**

DEPARTMENT OF BOTANY



BOS MEETING

27-10-2021

ACADEMIC YEAR - (2021-22)

ODD SEM – I, III & V

Minutes of the meeting of Board of studies in Botany for the Autonomous courses of AG & SG Siddhartha Degree College of Arts & Science, Vuyyuru, held at 10:30 A.M on 27-10-2021 in the Department of Botany through online.

Members Present:-

- 1).....Chairman
(Smt. CH. Beulah Ranjani) Head, Department of Botany
AG & SG S Degree College of Arts & Science
Vuyyuru- 521165.
- 2).....University
(Sri. Dr. K. Ramesh) Nominee Department of Botany &
Head (I/c) Botany,
The Hindu College, Guntur .
- 3).....Academic
(Sri. Dr.Ch. Srinivasa Reddy) Council Nominee Lecture in Botany,
SRR& CVR Govt. Degree College,
Vijayawada, 520004.
- 4).....Academic
(Smt.V. Bhagya Lakshmi) Council Nominee Head, Department of Botany
SDMSK,
Vijayawada,
- 5).....Industrialist.
(Sri. S. Krishna Suman) Natural farming.
yakamuru
Vuyyuru, Krishna d.t
- 6).....Member
(Sri. N. Ramana Rao) Ad hoc Lecturer in Botany
AG & SGS Degree College of Arts &
Science (Autonomous),
Vuyyuru-521165.
- 7).....Member
(Ms. G. Rebecca Rachel) Ad hoc Lecturer in Botany
AG & SGS Degree College of Arts &
Science (Autonomous),
Vuyyuru-521165.
- 8).....student representative
(Ms K. Anusha MSc) Lecturer in chaitanya college,
Gudiwada

Agenda for B.O.S Meeting:

1. To recommend the syllabi (Theory & Practical), Model question paper for I Semester of I B.Sc (BZC, AQUA) in the academic year 2021-22.
2. To recommend the syllabi (Theory & Practical), Model question paper & Guide lines for III Semester of II B.Sc (BZC,AQUA) in the academic year 2021-22.
3. To recommend the syllabi (Theory & Practical), Practical syllabus, Model question paper & Guide lines for V Semesters of III B. Sc (BZC, AQUA) for the academic year 2021-22
4. To recommend the Blue print for the Semester –End exams for I, III & V Semesters of I, II & III B. Sc (BZC, AQUA) for the academic year 2021-22.
5. To recommend the teaching and evaluation methods to be followed under Autonomous statues.
6. Any other matter.

CH. Beulah Rajani

Chairman

RESOLUTIONS

1. It is resolved to continue the same syllabi (Theory & Practical), model question paper & guide lines to be followed by the question paper setters of Botany of I semester of I B.Sc (B.Z.C, AQUA) under Choice Based Credit System (CBCS) approved by the Academic Council of 2021-22.
2. It is resolved to implement the syllabi (Theory & Practical), model question paper & guide lines to be followed by the question papers under Choice Based Credit System (CBCS) setters of Botany of III semesters of II B.Sc. (B.Z.C, AQUA) approved by the Academic Council of 2021 -22.
3. It is resolved to implement the same syllabi & model papers under Choice Based Credit System (CBCS) setters of Botany of V semesters of III B.Sc. (B.Z.C, AQUA) approved by the Academic Council of 2021-22.
4. It is resolved to continue the same Blue prints of I, III & V Semesters of B. Sc Botany for the Academic year 2021-22..
5. It is resolved to continue the following teaching and evolution methods for the Academic year 2021-22.
6. Any other matter.

Teaching methods:

- Besides the conventional methods of teaching, we use modern technology i.e. Using of OHP and LCD projector to display on U boards etc; for better understanding of concepts.

Evaluation of a student is done by the following procedure:

I. Internal Assessment Examinations:

- **Out of maximum 100 marks** in each paper for **II & III B.Sc** , **30 marks** shall be allocated for internal assessment.
- Out of these 30 marks, 20 marks are allocated for announced tests. Two announced tests will be conducted and average of these two tests shall be deemed as the marks obtained by the student, 5 marks are allocated on the basis of candidate's percentage of attendance, 5 marks for seminars / assignments for the III & V semesters.
- It is resolved to continue the same as approved by Academic Council in 2021-22.
- There is no pass minimum for internal assessment for I,II,III B.Sc
- **Out of maximum 100 marks** in each paper for **I B.Sc**, **25marks** shall be allocated for internal assessment.
- Out of these 25 marks, 20 marks are allocated for announced tests. Two announced tests will be conducted and average of these two tests shall be deemed as the marks obtained by the student, 5 marks are allocated on the basis of candidate's percentage of attendance / assignments for the I semester.

II. Semester-End Examinations:

- The maximum marks for I B.Sc (BZC, AQUA) Semester - End examinations shall be 75 marks and duration of the examination shall be 3 Hours.
- The maximum marks for II & III B.Sc (BZC, AQUA) Semester-End examinations shall be 70 marks and duration of the examination shall be 3 Hours. Even through the candidate is absent for two IA-EXAMS /obtain zero marks the external marks are consider (if the candidate gets 40/70) and the result shall be declared as "PASS"
- Semester-End examinations shall be conducted in theory papers at the end of every semester while in practical papers; these examinations are conducted at end of I, III, & V semesters.
- Discussed and recommended for organizing Seminars, Guest lectures, Work-shops to upgrade the Knowledge of students, for the approval of the Academic Council.

Note: Only for the semester I, we are following same syllabus, question paper, guidelines of P.B. Siddhartha degree college & SDMS Mahila kalasala .

Chairman

Course Structure of BZC, AQUA Syllabus

year	semester	Paper code	Title of the paper	Marks(100)		Credits
				Internal assessment	End semester	
I	I	BOTIIA	Fundamentals of Microbes and Non-vascular plants	25	75	4
			Practical-I	10	40	2
II	III	BOT-301	Anatomy of angiosperms, Plant Ecology and Biodiversity	30	70	3
			Practical-III	25	25	2
III	V	BOT-501	Cell Biology, Genetics and Plant Breeding.	30	70	3
			Practical-v – 501	15	35	2
III	V	BOT-502	Plant ecology and Phyto geography	30	70	3
			Practical-v- 502	15	35	2

A.G.& S.G. SIDDHARTHA DEGREE COLLEGE OF ARTS & SCIENCE

Vuyyuru- 521165.

NAAC recredited at 'A' level

Autonomous -ISO 9001 – 2015 Certified

Title of the Paper: Fundamentals of Microbes and Non-vascular Plants

Semester : I

Course Code	BOT11A	Course Delivery Method	Class Room / Blended Mode - Both
Credits	4	CIA Marks	25
No. of Lecture Hours / Week	4	Semester End Exam Marks	75
Total Number of Lecture Hours	60	Total Marks	100
Year of Introduction :2017-18	Year of Offering: 2021 - 22	Year of Revision:2021 - 22	Percentage of Revision: 50 %

Learning Objectives:

On successful completion of this course, the students will be able to:

1. To understand origin of life on the earth and analyze structure, disease symptoms and transmission of plant viruses.
2. To understand the diversity and characteristics of Prokaryotes.
3. To understand the characteristics of Fungi and Lichens.
4. To understand the characteristics of Algae.
5. To understand the characteristics of Bryophyta.

PREREQUISITE

- Knowledge of microbes, thallophytes and Bryophytes at +2 level

COURSE OUTCOMES

By the end of the course students will be able to

CO 1	Explain origin of life on the earth.
CO 2	Illustrate diversity among the viruses and prokaryotic organisms and can categorize them.
CO 3	Analyze and ascertain the plant disease symptoms due to viruses, bacteria and fungi.
CO 4	Classify fungi, lichens, algae and bryophytes based on their structure, reproduction and life cycles.
CO 5	Evaluate the ecological and economic value of microbes, thallophytes and bryophytes.

SYLLABUS

UNIT – I	<p>Origin of life and viruses Origin of life, concept of primary Abiogenesis; Miller and Urey experiment. Five kingdoms classification of R.H. Whittaker. Discovery of microorganisms, Pasteur experiments, germ theory of diseases. Shape and symmetry of viruses; structure of TMV and Gemini virus; multiplication of TMV, a brief account of Prions and Viroids A general account on symptoms of plant diseases caused by Viruses. Transmission of plant viruses and their control. Significance of viruses in vaccine production, bio-pesticides</p>
UNIT – II	<p>Special groups of Bacteria and Eubacteria Brief account of Archaeobacteria, Actinomycetes and Cyanobacteria. Cell structure and nutrition of Eubacteria. Reproduction- Asexual (Binary fission and endospores) and bacterial recombination (Conjugation, Transformation, Transduction). Economic importance of Bacteria with reference to their role in Agriculture and industry (fermentation and medicine) A general account on symptoms of plant diseases caused by Bacteria; Citrus canker</p>
UNIT – III	<p style="text-align: center;">Fungi & Lichens</p> <p>General characteristics of fungi and Ainsworth classification (upto classes). Structure, reproduction and life history of (a) <i>Rhizopus</i> (Zygomycota) and (b) <i>Puccinia</i> (Basidiomycota). Economic uses of fungi in food industry, pharmacy and agriculture. A general account on symptoms of plant diseases caused by Fungi; Blast of Rice. Lichens- structure and reproduction.</p>
UNIT – IV	<p>General characteristics of Algae (pigments, flagella and reserve food material), Fritsch classification (upto classes). Thallus organization and life cycles in Algae. Occurrence, structure, reproduction and life cycle of a) <i>Spirogyra</i> (Chlorophyceae) and (b) <i>Polysiphonia</i> (Rhodophyceae). Economic importance of Algae</p>
UNIT – V	<p>Bryophytes General characteristics of Bryophytes; classification upto classes. Occurrence, morphology, anatomy, reproduction (developmental details are not needed) and life cycle of (a) <i>Marchantia</i> (Hepaticopsida) and (b) <i>Funaria</i> (Bryopsida). General account on evolution of sporophytes in Bryophyta</p>

Text books:

1. Botany – I (Vrukshasastram-I) : Telugu Akademi, Hyderabad
2. Pandey, B.P. (2013) *College Botany, Volume-I*, S. Chand Publishing, New Delhi

Books for Reference:

1. Prescott, L. Harley, J. and Klein, D. (2005)*Microbiology, 6th edition*, Tata McGraw –Hill Co. New Delhi.
2. Alexopoulos, C.J., C.W.Mims&M.Blackwell (2007) *Introductory Mycology*, Wiley& Sons, Inc., New York
3. Fritsch, F.E. (1945)*The Structure & Reproduction of Algae (Vol. I & Vol.II)*Cambridge University Press Cambridge, U.K..

A .G & S .G. SIDDHARTHA DEGREE COLLEGE OF ARTS AND SCIENCE, VUYYURU

(An Autonomous college in the jurisdiction of Krishna University)

MODEL QUESTION PAPER- Theory Examination(s) at Semester end 2021-2022

TITLE OF THE PAPER: Fundamentals of Microbes and Non-vascular Plants (Viruses, Bacteria, Fungi, Lichens, Algae and Bryophytes)

Course Code: BOTT11A

Max. Time: 3 Hrs.

Max. Marks: 75 M

SECTION – A

**Answer FIVE of the following questions. Draw labelled diagrams wherever necessary. 5 x 5=25M
ONE question should be given from each Unit in the syllabus.**

1. Five kingdom classification of Whittaker **CO1-L2**
2. Germ theory of diseases **CO1-L2**
3. Which groups of organisms are once considered as algae? Give an account of general characters of that group **CO2- L1**
4. What are the symptoms of citrus canker? Mention the causal organism of citrus canker. **CO2- L2.**
5. Ainsworth classification of fungi **CO-3 L2**
6. Why lichens are considered as unique and composite organisms? **CO-3 L1**
Why diplobiontic life cycle is called so? Mention an alga that shows diplobiontic life cycle. List out the phases exhibited in one such life cycle studied by you. **CO-4 L1**
8. Vegetative reproduction in Bryophytes. **CO5-L2**

SECTION – B

Answer the following questions.

5x10= 50 M

**Two questions (A & B) are to be given from each Unit in the syllabus (internal choice in each unit).
Student has to answer 5 questions by choosing one from a set of questions given from a Unit.**

- 9 a) Give an account of structure and multiplication of TMV? **CO1- L2**
OR
b) Explain the significance of viruses in vaccine production, bio-pesticides . **CO1-L2**
10. a) Whether bacteria exhibit sexual reproduction or not ? Elucidate different methods of bacterial recombination. **CO2- L2**
OR
b) Explain the role of bacteria in agriculture and industry . **CO2- L2**
- 11 a) Why *Puccinia* is called as macro cyclic rust? Explain the stages of the fungus on Primary host. **CO3-L1.**
OR
b) Why lichens are considered as ‘pioneers of colonization’? Write about reproduction in Lichens. **CO3-L1**
- 12 a). What is thallus? Describe various types of thalli found in algae. **CO4-L2**
OR
b) Explain life cycle of *Spirogyra* . **CO-4 L2**
13. a) Describe morphological and anatomical features of *Marchantia*. **CO5- L2**
OR
b) What is the dominant phase in the life cycle of bryophytes?
Give account on of sporophyte evolution in Bryophytes. **CO5-L 2**

A .G & S .G. SIDDHARTHA DEGREE COLLEGE OF ARTS AND SCIENCE, VUYYURU

(An Autonomous college in the jurisdiction of Krishna University)

Practical Syllabus

SEMESTER- I

PAPER- I

CREDITS : 02

BOTANY	BOTT11A	WEF: 2021-2022	B. Sc (BZC), AQUA
--------	---------	----------------	-------------------

Title of the paper: Fundamentals of Microbes and Non-vascular Plants

(Viruses, Bacteria, Fungi, Lichens, Algae and Bryophytes)

NO OF HOURS: 30

Learning outcomes: On successful completion of this practical course, student shall be able to

- Demonstrate the techniques of use of lab equipment, preparing slides and identify the material and draw diagrams exactly as it appears.
- Observe and identify microbes and lower groups of plants on their own.
- Demonstrate the techniques of inoculation, preparation of media etc.
- Identify the material in the permanent slides etc.

Practical Syllabus:

1. Knowledge of Microbiology laboratory practices and safety rules.
2. Knowledge of different equipment for Microbiology laboratory (Spirit lamp, Inoculation loop, Hot-air oven, Autoclave/Pressure cooker, Laminar air flow chamber and Incubator) and their working principles. (In case of the non- availability of the laboratory equipment the students can be taken to the local college/clinical lab. with required infrastructural facilities or they can enter a linkage with the college/lab for future developments and it will fetch credits during the accreditation by NAAC).
3. Demonstration of Gram's staining technique for Bacteria.
4. Study of Viruses (Corona, Gemini and TMV) using electron micrographs/ models.
5. Study of Archaeobacteria and Actinomycetes using permanent slides/ electron micrographs/diagrams.
6. Study of *Anabaena* and *Oscillatoria* using permanent/temporary slides.
7. Study of different bacteria (Cocci, Bacillus, Vibrio and Spirillum) using permanent or temporary slides/ electron micrographs/ diagrams.
8. Study/ microscopic observation of vegetative, sectional/anatomical and reproductive structures of the following using temporary or permanent slides/ specimens/ mounts
 - a. Fungi : *Rhizopus*, *Penicillium* and *Puccinia*.
 - b. Lichens: Crustose, foliose and fruticose

c. Algae : *Volvox*, *Spirogyra*, *Ectocarpus* and *Polysiphonia*

d. Bryophyta : *Marchantia* and *Funaria*

9. Study of specimens of Tobacco mosaic disease, Citrus canker and Blast of Rice.

Suggested Manuals:

1. Vasista, B.R. (2018). Botany for degree students - Algae - S. Chand and company Ltd., New Delhi.

2. Dubey, H.C (2018). A text book of Fungi, bacteria and Viruses. Vikas publishing House, New Delhi.

3. Smith, G.M (1955). Cryptogamic Botany (Vol. I Algae, Fungi, & Lichens)

McGraw-Hill Book Co., New York

A .G & S .G. SIDDHARTHA DEGREE COLLEGE OF ARTS AND SCIENCE, VUYYURU

(An Autonomous college in the jurisdiction of Krishna University)

MODEL QUESTION PAPER FOR PRACTICAL EXAMINATION

Semester – I/ Botany Core Course – 1

**TITLE OF THE PAPER: Fundamentals of Microbes and Non-vascular Plants
(Viruses, Bacteria, Fungi, Lichens, Algae and Bryophytes)**

Max. Time: 3 Hrs.

Max. Marks: 40

-
1. Take the T.S. of material 'A' (Fungi), make a temporary mount and make comments about identification. 8M
 2. Identify any 2 algae from the mixture (material 'B') given with specific comments about identification. 8M
 3. Take the T.S. of material 'C' (Bryophyta), make a temporary mount and make comments about identification. 8M
 4. Identify the following with specific reasons 4x2=8M
 - A. A laboratory equipment of Microbiology
 - B. B. Virus
 - C. Archaeobacteria /Ascomycete /Cyanobacteria/ Eu-Bacteria
 - D. Lichen
 5. Record + Viva-voce 5+3 = 8 M

A.G.& S.G. SIDDHARTHA DEGREE COLLEGE OF ARTS & SCIENCE

Vuyyuru - 521165.

NAAC reaccredited at 'A' level

Autonomous -ISO 9001 – 2015 Certified

Title of the Paper: Anatomy and Embryology of Angiosperms, Plant Ecology and Biodiversity

Semester: III

Course Code	BOT11A	Course Delivery Method	Class Room / Blended Mode - Both
Credits	3	CIA Marks	30
No. of Lecture Hours / Week	4	Semester End Exam Marks	70
Total Number of Lecture Hours	60	Total Marks	100
Year of Introduction :2017-18	Year of Offering: 2021 - 22	Year of Revision:2021 - 22	Percentage of Revision: 50 %

Learning Objectives:

On successful completion of this course, the students will be able to:

1. To understand Anatomy of Angiosperms - organization of tissues and tissue systems in plants..
2. To understand the various aspects of embryology.
3. To understand the basic concepts of plant ecology.
4. To understand the various parameters of population and community ecology.
5. To understand the importance of biodiversity

THEORY: Learning outcomes:

- ✚ On successful completion of this course, the students will be able to;
 - ✚ Understand on the organization of tissues and tissue systems in plants.
 - ✚ Illustrate and interpret various aspects of embryology.
 - ✚ Discuss the basic concepts of plant ecology, and evaluate the effects of environmental and biotic factors on plant communities.
 - ✚ Appraise various qualitative and quantitative parameters to study the population and community ecology.
 - ✚ Correlate the importance of biodiversity and consequences due to its loss.
 - ✚ Enlist the endemic/endangered flora and fauna from two biodiversity hot spots in India and assess strategies for their conservation.
-

SYLLABUS

Unit – 1	Anatomy of Angiosperms
	<p>Organization of apical meristems: Tunica-carpus theory and Histogen theory. Tissue systems–Epidermal, ground and vascular. Anomalous secondary growth in <i>Boerhaavia</i> and <i>Dracaena</i>. Study of timbers of economic importance - Teak, Red sanders and Rosewood.</p>
Unit – 2	Embryology of Angiosperms
	<p>Structure of anther, anther wall, types of tapetum. Microsporogenesis and development of male gametophyte. Structure of ovule, megasporogenesis; monosporic (<i>Polygonum</i>), bisporic (<i>Allium</i>) and tetrasporic (<i>Peperomia</i>) types of embryo sacs. Outlines of pollination, pollen – pistil interaction and fertilization. Endosperm - Types and biological importance - Free nuclear, cellular, helobial and ruminant. Development of Dicot (<i>Capsella bursa-pastoris</i>) embryo.</p>
Unit – 3	Basics of Ecology
	<p>Ecology: definition, branches and significance of ecology. Ecosystem: Concept and components, energy flow, food chain, food web, ecological pyramids. Plants and environment: Climatic (light and temperature), edaphic and biotic factors. Ecological succession: Hydrosere and Xerosere.</p>
Unit – 4	Population, Community and Production Ecology
	<p>Population ecology: Natality, mortality, growth curves, ecotypes, ecads Community ecology: Frequency, density, cover, life forms, biological spectrum Concepts of productivity: GPP, NPP and Community Respiration Secondary production, P/R ratio and Ecosystems</p>
Unit – 5	Basics of Biodiversity
	<p>Biodiversity: Basic concepts, Convention on Biodiversity - Earth Summit. Value of Biodiversity; types and levels of biodiversity and Threats to biodiversity Biodiversity Hot spots in India. Biodiversity in North Eastern Himalayas and Western Ghats. Principles of conservation: IUCN threat-categories, RED data book Role of NBPGR and NBA in the conservation of Biodiversity.</p>

Text books:

1. Botany – III (Vrukshasastram-I) : Telugu Akademi, Hyderabad
2. Botany – IV (Vrukshasastram-II) : Telugu Akademi, Hyderabad
3. Pandey, B.P. (2013) *College Botany, Volume-II*, S. Chand Publishing, New Delhi

Books for Reference:

- Esau, K. (1971) *Anatomy of Seed Plants*. John Wiley and Son, USA.
- Paula Rudall (1987) *Anatomy of Flowering Plants: An Introduction to Structure and Development*. Cambridge University Press, London
- Bhojwani, S. S. and S. P. Bhatnagar (2000) *The Embryology of Angiosperms (4th Ed.)*, Vikas Publishing House, Delhi.

A.G & S.G. Siddhartha Degree College of Arts & Science

An autonomous college in the jurisdiction of Krishna University

BOTANY	BOT- 301C	w.e.f. 2021-22	B. Sc. (BZC), AQUA
--------	-----------	----------------	--------------------

II B. Sc – BOTANY

Model Question Paper

SEMESTER- III

PAPER-III: Anatomy and Embryology of Angiosperms, Plant Ecology and Biodiversity

Time: 3 Hours

Max. Marks: 70

SECTION-A

Answer any **four** of the following questions.

4x 5 = 20Marks

(Draw diagrams wherever necessary)

1. Histogen theory.
2. Rosewood.
3. Ruminant endosperm
4. Energy flow
5. Significance of ecology.
6. Natality
7. GPP.
8. NBPGR

SECTION-B

Answer any **five** of the following questions.

5x10 = 50Marks

(Draw diagrams wherever necessary)

9. Explain about Organization of apical meristems:
10. Describe the Anomalous secondary growth in *Boerhaavia*?
11. Write an essay on ICBN.
12. Describe vegetative & floral characters of Asclepiadaceae.
13. Write an essay on ecological pyramids?
14. What is Ecological succession: Write an essay on Hydrosere?
15. Write the characteristics of population ecology?
16. Give an account of Value of Biodiversity?

Guide lines for paper setter: (for Paper III – BOT- 301) w.e.f 2021-22

1. In **section A**: Unit II, V must carry **one** question, Unit I,III & IV must carry **two** questions.
2. In **section- B**: Set minimum **two** questions from Unit I, II, III . **One** question each from Unit IV and Unit V.
3. See the following table and Model paper for marks distribution.
4. Please provide the scheme of valuation for the paper.
5. Question paper should be both in English and Telugu media.

Unit	Section - A		Section - B		Weightage in
	Questions	Marks	Questions	Marks	Marks
Unit – I	2		2		
	10		20		30
Unit - II	1		2		
	05		20		25
Unit – III	2		2		
	10		20		30
Unit – IV	2		1		
	10		10		20
Unit – V	1		1		
	05		10		15
Max. Q & marks	8	(x 5) = 40	8	(x 10) = 80	(Total questions =16) Total marks = 120
Max. Q and marks for Valuation	Questions	Marks	Questions	Marks	Max. marks
	4	(4 X 5M) = 20 M	5	(5 X 10M)= 50 M	70M

INTERNAL EXAMS - 30Marks

(**20 marks** for unit tests, 5marks for Attendance **5** marks for seminars)

Practical syllabus of Botany Core Course – 3 /Semester – III

Anatomy and Embryology of Angiosperms, Plant Ecology and Biodiversity

(Total hours of laboratory exercises 30 Hrs. @ 02 Hrs./Week)

Course Outcomes:

On successful completion of this practical course students shall be able to:

1. Get familiarized with techniques of section making, staining and microscopic study of vegetative, anatomical and reproductive structure of plants.
2. Observe externally and under microscope, identify and draw exact diagrams of the material in the lab.
3. Demonstrate application of methods in plant ecology and conservation of biodiversity and qualitative and quantitative aspects related to populations and communities of plants.

Practical Syllabus

1. Tissue organization in root and shoot apices using permanent slides.
2. Anomalous secondary growth in stems of *Boerhavia* and *Dracaena*.
3. Study of anther and ovule using permanent slides/photographs.
4. Study of pollen germination and pollen viability.
5. Dissection and observation of Embryo sac haustoria in *Santalum* or *Argemone*.
6. Structure of endosperm (nuclear and cellular) using permanent slides / Photographs.
7. Dissection and observation of Endosperm haustoria in *Crotalaria* or *Coccinia*.
8. Developmental stages of dicot and monocot embryos using permanent slides / photographs.
9. Study of instruments used to measure microclimatic variables; soil thermometer, maximum and minimum thermometer, anemometer, rain gauge, and lux meter. (visit to the nearest/local meteorology station where the data is being collected regularly and record the field visit summary for the submission in the practical).
10. Study of morphological and anatomical adaptations of hydrophytes and xerophytes (02 each).
11. Quantitative analysis of herbaceous vegetation in the college campus for frequency, density and abundance.
12. Identification of vegetation/various plants in college campus and comparison with Raunkiaer's frequency distribution law.
13. Find out the alpha-diversity of plants in the area.
14. Mapping of biodiversity hotspots of the world and India

Model paper for Practical Examination

Semester – III/ Botany Core Course – 3

Anatomy and Embryology of Angiosperms, Plant Ecology and Biodiversity

Max. Time: 3 Hrs.

Max. Marks: 50

1. Take T.S. of the material 'A' (Anatomy), prepare a temporary slide and justify the identification with specific reasons. 7M
2. Write the procedure for the experiment 'B' (Embryology) and demonstrate the same. 6M
3. Take T.S. of the material 'C', prepare a temporary slide and justify the identification with specific reasons. 4M
4. Identify the following with specific reasons. 4 x 2 = 8 M
 - D. Anatomy/Embryology
 - E. Ecology instrument
 - F. Mapping of Biodiversity hot spot
 - G. Endemic/endangered plant/animal

Total Marks: 25

Internals:

1. Record 10M
2. Viva-voce3M
3. Field trip4M
4. Internal practical exam 8M

Total Marks:25

Total marks: 50

Suggested co-curricular activities for Botany Core Course-3 in Semester-III:

A. Measurable :

a. Student seminars :

1. Anatomy in relation to taxonomy of Angiosperms.
2. Nodal anatomy
3. Floral anatomy
4. Embryology in relation to taxonomy of Angiosperms.
5. Apomictics and polyembryony.
6. Biogeochemical cycles- Carbon, Nitrogen and Phosphorous.
7. Deforestation and Afforestation.
8. Green house effect and ocean acidification.
9. The Montreal protocol and the Kyoto protocol.
10. Productivity of aquatic ecosystems.
11. Mangrove ecosystems in India.
12. Kollerulake – Ramsar site.
13. Biodiversity hotspots of the world.
14. Origin of Crop plants - Vavilov centers
15. Agrobiodiversity
16. International organizations working on conservation of Biodiversity
17. Nagoya protocol – ABS system.
18. Endemic and endangered plants in Andhra Pradesh.

b. Student Study Projects :

1. Stomata structure in plants from college campus/ their native place.
2. Report on xylem elements in plants using maceration technique.
3. Collection of information on famous herbaria in the world and preparation of a report.
4. Microscopic observations on pollen morphology from plants in college Campus/ their native locality.
5. Study report on germination and viability of pollen in different plants.
6. Observation of anthesis time in different plants and their pollinators.
7. A report on autecology and synecology of some plants in college campus or their native place.
8. Collection of photos of endemic/endangered plant and animal species to Makean album.

9. Biodiversity of the college or their own residential/ native area.
10. Collection of seeds/vegetative organs of rare plant species from their localities and to raise/grow in college garden

C .Assignments: Written assignment at home / during '0' hour at college; preparation of charts with drawings, making models etc., on topics included in syllabus.

B. General :

1. Visit to an arboretum/silviculture station/Forest research institute to see the live timber yielding plants or to visit a local timber depot. to observe various woods.
2. Field visit to a nearby ecosystem to observe the abiotic-biotic relationships.
3. Visit to National park/Sanctuary/Biosphere reserve etc., to observe in-situ conservation of plants and animals.
4. Visit to a Botanical garden or Zoo to learn about ex-situ conservation of rare plants or animals.
5. Group Discussion (GD)/ Quiz/ Just A Minute (JAM) on different modules in syllabus of the course.

A.G.& S.G. SIDDHARTHA DEGREE COLLEGE OF ARTS & SCIENCE

Vuyyuru - 521165.

NAAC reaccruited at 'A' level

Autonomous -ISO 9001 – 2015 Certified

Title of the Paper: Cell Biology, Genetics and Plant Breeding

Semester : V

Course Code	BOT-501	Course Delivery Method	Class Room / Blended Mode - Both
Credits	3	CIA Marks	30
No. of Lecture Hours / Week	4	Semester End Exam Marks	70
Total Number of Lecture Hours	60	Total Marks	100
Year of Introduction :2017-18	Year of Offering: 2017 - 18	Year of Revision:2021 - 22	Percentage of Revision: 50 %

Learning Objectives:

On successful completion of this course, the students will be able to:

1. To understand the Cell, Structure and functions
2. To understand the Genetic Material
3. To understand the basic concepts of plant ecology.
4. To understand the various parameters of population and community ecology.
5. To understand the importance of biodiversity

SYLLABUS

UNIT-I	Cell Biology Cell, Ultra Structure and functions of cell wall. Molecular Organization of cell membranes. Chromosomes; morphology, organization of DNA in a chromosome (Nucleosome model) Euchromatin and Heterochromatin.
UNIT-II	Genetic Material DNA as the Genetic Material: Griffith's and Avery's Transformation Experiment. Hershey - Chase Bacteriophage experiment. DNA Structure (Watson & crick model) and replication of DNA (SemiConservative). Types of RNA (mRNA, tRNA, rRNA), their structure and function.
UNIT- III	Mendelian Inheritance Mendelian Inheritance (Mono – Di-hybrid Crosses), Back cross and Text cross. Linkage: concept, complete and In-complete Linkage, Coupling and Repulsion; Linkage Maps Based on Two and Three Point cross. Crossing over concept and significance.
UNIT-IV	Gene Expression Organization of gene, Transcription and Translation. Mechanism and regulation of Gene Expression in Prokaryotes (Lac operon). Mutations: Chromosomal Aberrations, Gene Mutations and Transposable Elements
UNIT-V	Plant Breeding Introduction and objectives of Plant Breeding. Methods of Crop Improvement: Procedure, Advantages and limitations of Introduction, Selection and Hybridization (Out lines only).

B.Sc – BOTANY
SEMESTER -V. THEORY MODEL PAPER

Time: 3 Hours

Max. Marks: 70

SECTION-A

Answer any FOUR of the following question

4 x 5=20M.

(Draw diagrams wherever necessary)

1. Nucleosome
2. Griffith experiment.
3. t RNA
4. Back cross and test cross.
5. Transcription.
6. Three point test cross.
7. Hybridization.
8. Crossing over.

SECTION-B

Answer any FIVE of the following questions.

5 x 10 = 50M.

(Draw diagrams wherever necessary)

9. Describe the Ultra structure and functions of cell membrane.
10. What is cell theory? Write about eukaryotic cell components.
11. Write about structure and replication of DNA.
12. DNA as a genetic material proof with suitable experiments.
13. Explain the Mendel's law of inheritance.
14. Define linkage. Describe the different types of Linkage.
15. Write an essay on mechanism and Regulation of gene Expression in Prokaryotes.
16. Discuss about methods of Crop improvement.

Guide lines for paper setter: (for Paper V-BOT-501) W.e.f. 2021-22

1. In Section A: Unit I, III, V must carry one question from each unit. Unit II must carry 2 questions and Unit IV must carry three questions.
2. In section-B: Set minimum Two questions from Unit I, II & III
3. See the following table and Model paper.
4. Please provide the scheme of valuation for the paper.
5. Question paper should be both in English and Telugu media.

Unit	Section - A		Section - B		Weightage in
	Questions	Marks	Questions	Marks	Marks
Unit – I	1		2		25
	5		20		
Unit – II	2		2		30
	10		20		
Unit –III	1		2		25
	5		20		
Unit-IV	3		1		25
	15		10		
Unit-V	1		1		15
	5		10		
Max .Q & marks	8 (x 5) =40		8 (x 10) = 80		(Total questions =16) Marks 120
Max. Q and marks for Valuation	Questions	Marks	Questions	Marks	Max. marks
	4		5		70
	(4 x 5) = 20		(5 x 10) = 50		

INTERNAL EXAMS - 30Marks

(20 marks for unit tests, 5marks for Attendance 5 marks for seminars)

III B.SC-BOTANY Practical paper
Cell Biology, Genetics and Plant Breeding

SEMESTER-V

BOT-501-P

Time: 3hr

Total hours of teaching 30hrs @ 2 hrs per week

Max.marks:50

1. Study of the structure of cell organelles through photomicrographs.
2. Study of plant cell through temporary mounts.
3. Study of various stages of mitosis using cytological preparation of Onion root tips.
4. Study of DNA packing by micrographs.
5. Numerical problems solving Mendal's Laws of inheritance.
6. Chromosome mapping using 3 point test cross data.
7. Hybridization techniques –emasulation. Bagging (for demonstration only).
8. Field visit to a plant breeding research station.

III B.SC-SEMESTER-V, BOTANY PRACTICAL MODEL PAPER

PAPER –V: CELL BIOLOGY GENETICS AND PLANT BREEDING

1. Perform the Experiment A Squash technique.....12M
2. Give the experimental protocol of the experiments. B.....04M
3. Solving numerical problems on Mendelian inheritance....C, D..... $2 \times 7 \frac{1}{2} = 15M$
4. Record.....05M
- Viva.....04M
- Internal Practical Exam.....10M

III B.SC-BOTANY Syllabus SEMESTER-V

Practical paper – V: Cell Biology, Genetics and Plant Breeding

Total hours of teaching 30hrs @ 2 hrs per week

1. Perform the Experiment A.

Squash technique4M

Procedure.....4M

diagram2M =10

2. Give the experimental protocol of the experiments. B.....4M

3. Genetic problem C, D

Salvation of problem..... 5M

Reasoning.....2¹/₂M

2X7¹/₂=15M

Viva4M

Internal:

a) Record.....5 M.

b)Internal Practical Exam.....10M

Books for Reference:

1. Old, R.W. and Primrose S.B. 1994, Principles of Gene Manipulation Blackwell Science,19 London 2. Grierson, D. and Convey S.N. 1989, Plant Molecular Biology, Blackie Publishers, NewYork.
2. Lea, P.J. and Leegood R.C. 1999, Plant Biochemistry and Molecular Biology, John Wiley and Sons, London.
3. Power C.B., 1984, Cell Biology, Himalaya Publishing Co. Mumbai
4. De. Robertis and De Robertis, 1998, Cell and Moleceular Biology, K.M. Verghese andCompany .

A.G.& S.G. SIDDHARTHA DEGREE COLLEGE OF ARTS & SCIENCE

Vuyyuru - 521165.

NAAC recredited at 'A' level

Autonomous -ISO 9001 – 2015 Certified

Title of the Paper: PLANT ECOLOGY & PHYTOGEOGRAPHY

Semester : V

Course Code	BOT-502	Course Delivery Method	Class Room / Blended Mode - Both
Credits	3	CIA Marks	30
No. of Lecture Hours / Week	4	Semester End Exam Marks	70
Total Number of Lecture Hours	60	Total Marks	100
Year of Introduction :2017-18	Year of Offering: 2017 - 18	Year of Revision:2021 - 22	Percentage of Revision: 50 %

Learning Objectives:

On successful completion of this course, the students will be able to:

1. To understand the elements of ecology.
2. To understand the ecosystem
3. To understand the basic concepts of plant ecology.
4. To understand the various parameters of population and community ecology.
5. To understand the importance of biodiversity

SYLLABUS

UNIT-I	ELEMENTS OF ECOLOGY Ecology: Definition, branches and significance of ecology. Claimatic factors: Light, Temperature. Edaphic factor: Origin, formation, composition and soil profile. Biotic factor, Ecological adaptations of Plants.
Unit- II	Ecosystem Ecology Ecosystem: concept and components, energy flow, food chain, food web, Ecological Pyramids. Productivity of ecosystem-Primary, Secondary and Net productivity. Biogeochemical cycles- Carbon, Nitrogen and Phosphorous.
Unit – III	Population & Community ecology Population- defination, characteristics and importance (Density, Natality, Mortality, Growth Curves) outlines- ecotypes. Plant communities- characters of a community, outlines – Frequency, density, cover, life forms, Biological Spectrum. Ecological Succession: Hydrosere and Xerosere.
Unit-IV	Phytogeography Principles of Phytogeography, Distribution (Wides, Endemic, Discontinuous species). Phytogeography regions of India. Endemism – types and Causes.
Unit-V	Plant Biodiversity and its Importance Definition, Levels of Biodiversity – genetic, species and ecosystem. Biodiversity and Hot-spots of India: North Eastern, Himalayas and Western Ghats. Loss of Biodiversity-causes and Conservation (In-situ and Ex-Situ Methods).

B.Sc – BOTANY

SEMESTER –VI THEORY MODEL PAPER

PLANT ECOLOGY & PHYTOGEOGRAPHY

Time: 3 Hours

Max. Marks: 70

SECTION-A

Answer any FOUR of the following question.

4 x 5= 20M.

(Draw diagrams wherever necessary)

1. Soil profile.
2. Biotic factor.
3. Food web.
4. Energy Flow in Ecosystem.
5. Natality.
6. Biological Spectrum
7. Endemism.
8. Red-Data book.

SECTION-B

Answer any Five of the following questions.

5 x 10 = 50M.

(Draw diagrams wherever necessary)

9. Discusses the importance of Temperature Factor on Plant Growth.
10. Briefly Discuss the Ecological Adaptations of Xerophytes.
11. What are Ecological Pyramids? Describe the Pyramids of numbers, Biomass and Energy.
12. What are biogeochemical cycles? Give an account of Nitrogen cycle?
13. What is Plant Succession? Describe Hydrosere?
14. What are the Characters of Plant Communities?
15. What are Principles of Plant Phytogeography?
16. What is Biodiversity? Explain the Levels of Biodiversity.

Guide lines for paper setter: (for Paper V-BOT-502) W.e.f. 2021-22

1. In Section A: Unit I, II, III, must carry Two question from each unit. Unit IV, V must carry one question.
2. In section-B: Set minimum two questions from Unit I, II & III and Set One Question from IV, V.
3. See the following table and Model paper.
4. Please provide the scheme of valuation for the paper.
5. Question paper should be both in English and Telugu media.

Unit	Section – A		Section - B		Weightage in
	Questions	Marks	Questions	Marks	Marks
Unit – I	2		2		
		10		20	30
Unit – II	2		2		
		10		20	30
Unit – III	2		2		
		10		20	30
Unit-IV	1		1		
		5		10	15
Unit-V	1		1		
		5		10	15
Max. Q & marks	8	(x 5) = 40	8	(x 10) = 80	(Total questions = 16) Marks 120
Max. Q and marks for Valuation	Questions	Marks	Questions	Marks	Max. marks
	4		5		
		(4 x 5) = 20		(5 x 10) = 50	70

INTERNAL EXAMS – 30 Marks

(20 marks for unit tests, 5 marks for assignments and remaining 5 marks for seminar etc.)

**BOTANY PRACTICAL
PLANT ECOLOGY & PHYTOGEOGRAPHY**

SEMESTER- V

BOT-502-P

Total hours of teaching 30 hrs @ 3 hrs per week

1. Study of instruments used to measure microclimatic variables; soil thermometer, maximum and minimum thermometer, anemometer, psychrometer, rain gauge, and lux meter.
2. Permeability (percolation; total capacity as well as rate of movement) of different soil samples.
3. Determination of soil pH
4. Study of morphological and anatomical adaptations of hydrophytes and xerophytes. (4each)
5. Determination of minimal quadrat size for the study of herbaceous vegetation in the college campus by species area curve method.
6. Study of Phytoplankton and macrophytes from water bodies.
7. Study of species diversity index of vegetation.
8. Estimation of Primary Productivity of an ecosystem.
9. To study field vegetation with respect to stratification, canopy cover and composition.
10. Study of plants included in agro forestry and social forestry.
11. To locate the hotspots, phytogeographical regions and distribution of endemic plants in the map of India.
12. The following practical should be conducted in the Field/lab with the help of Photographs, herbarium, Floras, Red data book- Study of endangered plants species, critically endangered plants species, vulnerable plant species and monotypic endemic genera of India.

**BOTANY PRACTICAL
PLANT ECOLOGY & PHYTOGEOGRAPHY**

SEMESTER- V

BOT-502-P

Total hours of teaching 30 hrs @ 3 hrs per week

=====

1. Study Project under supervision.....12 Marks
2. Experiment **A** 07Marks
3. Anatomical adaptations of **B** (Section cutting)..... 07Marks
4. Spotters **C&D**(2x2 1/2) = 5 Marks
5. Record.....05Marks
6. Viva-Voc.....04Mrks
7. Internal practical exam.....10Marks

Total = 50 Marks

**BOTANY PRACTICAL
PLANT ECOLOGY & PHYTOGEOGRAPHY**

SEMESTER- V

BOT-502-P

Scheme of Valuation

1. Study Project under supervision
To study Honey Bees and Plants Yielding Honey 12 Marks
2. Experiment **A** -determination of soil porosity/PH..... 07Marks
3. Anatomical adaptations of **B** (Section cutting)
Xerophytes / Hydrophytes07Marks
4. Spotters **C&D** anemometer/rain gauze/lux meter (2x2 1/2) = 5 Marks
5. Viva-Voc.....04Mrks
6. Record..... 05Marks
7. Internal practical exam..... 10Marks

Total = 50 Marks

Books for Reference:

1. Daubenmire, R.F. (): Plants & Environment (2nd Edn.) John Wiley & Sons.,
New York22
2. Puri, .G.S. (1960): Indian Forest Ecology (Vol.I & II) Oxford Book Co., New Delhi
&Calcutta.
3. Billings, W.B. (1965): Plants and the Ecosystem Wadsworth Publishing Co., Inc.,
Belmont.
4. Misra, R. (1968): The Ecology work Book Oxford & INH Publishing Co., Calcutta

A.G & S.G.SIDDHARTHA DEGREE COLLEGE OF ARTS & SCIENCE
(Autonomous)

VUYYURU-521165, KRISHNA Dt., A.P.
Accredited by NAAC with "A" Grade



DEPARTMENT OF ZOOLOGY
MINUTES OF BOARD OF STUDIES
01-11-2021



ADUSUMILLI GOPALAKRISHNAIAH & SUGAR CANE GROWERS SIDDHARTHA DEGREE COLLEGE OF ARTS & SCIENCE, VUYYURU-521165, KRISHNA Dt., A.P. (AUTONOMOUS).

NACC reaccredited at 'A' level

Autonomous –ISO 9001-2015 Certified

DEPARTMENT OF ZOOLOGY

BOARD OF STUDIES MEETING: 1st November 2021

The Board of studies meeting of Department of Zoology was convened at 2:30 pm on 01/11/2021 under the chairmanship of Smt. D.A.Kiranmayee. Head of the Department. The members present have discussed various aspects such as changes to be made in the syllabi, scheme of Evaluation and Blue print both for theory and practical papers, Departmental activities for 2021-2022, Estimated Budget proposals 2021-2022 for implementing them effectively during the I,III,& V semester for the academic year 2021-2022 onwards.

The following members were present.

S.No	Name	Designation	signature
1.	Smt. D.A.Kiranmayee Head, Department of Zoology A.G&S.G.S Degree College Vuyyuru	Chair person	D.A.Kiranmayee
2	Smt. Dr.L.Suseela Bio Sciences & Bio technology Krishna University Machilipatnam.	University Nominee	Dr.L.Suseela
3.	Sri Dr.M.Viyay kumar Head, Department of Zoology SRR & CVR Govt. Degree College, Vijayawada.	Subject Expert	Dr.M.Viyay kumar
4.	Sri Ch. Venkateswaralu, Head, Department of Zoology, P.B. Siddhartha College, Vijayawada.	Subject Expert	Ch. Venkateswaralu,
5.	Sri.B. Appala Naidu, Asst. Project Manager, RGCA Manikonda.	Industrialist	B. Appala Naidu,
6.	Smt. K. Padmaja, Lecturer in Zoology, A.G&S.G.S Degree College Vuyyuru-	Member	K. Padmaja,
7.	Sri.Ch.Chiranjeevi, P.hd –Research Scholar, Dept.of Botany & Microbiology, Acharya Nagarjuna University Guntur.	Student Represent	Ch.Chiranjeevi,

ZOOLOGY

Agenda for B.O.S Meeting.

1. To recommend the syllabi (Theory & Practical), Model question paper for I Semester of I B.Sc (B.Z.C) for the academic year 2021 - 2022.
2. To recommend the syllabi (Theory & Practical), Model question paper for III Semester of II B.Sc (B.Z.C) for the academic year 2021 - 2022.
3. To recommend the syllabi (Theory & Practical), Model question paper for V Semester of III B.Sc (B.Z.C) for the academic year 2021 - 2022.
4. To recommend the Blue print for the semester end exam for I, III & V semester of I, II, III B.Sc (B.Z.C) for the academic year 2021 - 2022.
5. To introduce Life Skill Course Environmental Studies for I year students in this academic year 2021-22.
6. To introduce Skill Development Course Poultry Farming for III year students in this academic year 2021-22.
7. To recommend the teaching and evolution methods to be followed under Autonomous statues.
8. Any other matter.

Chairman.

D.A.Kiranmayee

ZOOLOGY- RESOLUTIONS

1. It is resolved to continue the same syllabi (Theory & Practical), model question paper & guide lines to be followed by the question paper setters of Zoology of I semester of I B.Sc. (B.Z.C) under Choice Based Credit System (CBCS) approved by the Academic Council of 2021 – 2022.
2. It is resolved to implement the syllabi (Theory & Practical), model question paper & guide lines to be followed by the question papers under Choice Based Credit System (CBCS) setters of Zoology of III Semester of II B.Sc. (B.Z.C) approved by the Academic Council of 2021 –2022.
3. It is resolved to implement the same syllabi & model papers under Choice Based Credit System (CBCS) Setters of Zoology of V semester of III B.Sc. (B.Z.C) approved by the Academic Council of 2021-2022.
4. It is resolved to Continue the same Blue prints of I,III, &V Semesters of B.Sc Zoology for the Academic year 2021-2022.
5. It is resolved to implement Life skill Course for I year students.
6. It is resolved to implement Skill Development Course for II year students.
7. It is resolved to continue the following teaching & evolution methods for the Academic year 2021-22.
8. Any other matter.

Teaching methods:

Besides the conventional methods of teaching, we use modern technology i.e. Using of OHP and LCD projector to display on U boards etc; for better understanding of concepts.

Evaluation of a student is done by the following procedure:

❖ Internal Assessment Examination:

- ❖ Out of maximum 100 marks in each paper for II, III B.Sc, 30 marks shall be allocated for internal assessment.
- ❖ Out of these 30 marks, 20 marks are allocated for announced tests (i.e . IA-1& IA-2). Two announced tests will be conducted and average of these two tests shall be deemed as the marks obtained by the student, 5 marks are allocated on the basis of candidate's percentage of attendance and remaining 5 marks are allocated for the assignment for II, III B.SC.
- ❖ Out of maximum 100 marks in each paper for I B.Sc, 25 marks shall be allocated for internal assessment.
- ❖ Out of these 25 marks, 20 marks are allocated for announced tests (i.e . IA-1& IA-2). Two announced tests will be conducted and average of these two tests shall be deemed as the marks obtained by the student, 5marks allocated on the basis of candidate's percentage of attendance / assignment for I semester.
- ❖ There is no pass minimum for internal assessment for I, II, III B.Sc

❖ Semester – End Examination:

- ❖ The maximum mark for I (BZC) semester – End examination shall be 75 marks and duration of the examination shall be 3 hours.
- ❖ The maximum mark for II, III B.Sc semester- End examination shall be 70 marks and duration of the examination shall be 3 hours. Even through the candidate is absent for two IA exams / obtain zero marks the external marks are considered (if the candidate gets 40/70) and the result shall be declared as “PASS”
- ❖ Semester – End examination shall be conducted in theory papers at the end of every semester, while in practical papers, these examinations are conducted at the end of I, III, & V semester for I, II & III B.Sc.
- ❖ Discussed and recommended for organizing Seminars, Guest lectures, Work – Shops to upgrade the Knowledge of students, for the approval of the Academic Council.

Note: - Only for the semester I, we are following same syllabus, Question paper, Guidelines of P.B. Siddhartha Degree College & SDMS Mahila Kalasala.

ADUSUMILLI GOPALAKRISHNAIAH & SUGAR CANE GROWERS SIDDHARTHA DEGREE COLLEGE OF ARTS & SCIENCE, VUYYURU-521165, KRISHNA Dt., A.P. (AUTONOMOUS).

ALLOCATION OF CREDITS

For the Papers offered during I, III & V Semesters

<i>Year</i>	<i>Semester</i>	<i>Title</i>	<i>Teaching hours</i>	<i>Internal marks</i>	<i>External marks</i>	<i>Credits</i>
I	I	Animal Diversity - I Biology of Non-Chordates	4	25	75	03
		Animal Diversity -Biology of Non-Chordates - Practical - I	2	10	40	01
II	III	Cell Biology, Genetics, Molecular biology & Evolution	4	30	70	03
		Practical Cell Biology, Genetics, Molecular biology & Evolution	2	25	25	01
III	V(501)	Animal Bio technology	4	30	70	03
		Practical - 501p Animal Bio technology	2	25	25	01
	V(502)	Animal Husbandry	4	30	70	03
		Practical - 502p Animal Husbandry	2	25	25	01
		Total Credits				16

Annexure- I

**ADUSUMILLI GOPALAKRISHNAIAH & SUGAR CANE GROWERS SIDDHARTHA DEGREE COLLEGE
OF ARTS & SCIENCE, VUYYURU-521165, KRISHNA Dt., A.P. (AUTONOMOUS).**

NACC reaccredited at 'A' level

Autonomous –ISO 9001-2015 Certified

Title of the Paper: **Animal Diversity Biology of Non – Chordates**

Semester: - I

Course Code	ZOOT11A	Course Delivery Method	Class Room/Blended Mode - Both
Credits	3	CIA Marks	25
No. of Lecture Hours/ Week	4	Semester End Exam Marks	75
Total Number of Lecture Hours	60	Total Marks	100
Year of Introduction : 2017-18	Year of Offering 2021-2022	Year of Revision – 2021-22	Percentage of Revision: 0%

AIM

- To know the biodiversity of invertebrates

LEARNING OBJECTIVES

- To understand the structural organization of animals from Protozoa to Hemichordate
- To understand the evolutionary relationship of different phyla from Protozoa to Hemichordate
- To understand the specific phenomena exhibited by different groups of invertebrates from Protozoa to Hemichordate
- To understand the taxonomic position and affinities of certain groups of invertebrates
As Connecting links
- To study the life cycles, and pathogenicity of certain

PREREQUISITE

- Knowledge of invertebrates acquired in Intermediate

COURSE OUTCOMES

By the end of the course students will be able to

- CO 1 Gain knowledge in the fundamental concepts underlying the structural complexity in the organization of invertebrates.
- CO 2 Understand biology and pathogenicity of parasites and their adaptations analyse remedial and preventive measures and promote the same in public domain.
- CO 3 Appreciate and evaluate the economic, commercial, medicinal and culture importance of invertebrates and their larval stages in relation to phylogeny
- CO 4 Describe the significance of connecting links in understanding the concept of evolution
- CO 5 Explain the significance of specific phenomena in different group's of invertebrates in relation to their adaptability for survival
- CO 6 Comprehend the systems biology of individual phyla with a specific type study and understand the origin and evolutionary relationship of different phyla and appreciate the uniqueness of individual phyla.

Syllabus
Course Details

Unit	Learning Units	Lecture Hours
I	<p>PROTOZOA AND PORIFERA Introduction to Non-chordates – Origin of metazoans Type study: <i>Polystomella</i> (structure and life cycle) Locomotion in protozoans Nutrition in protozoans Type study: <i>Sycon</i> (Structure, histology and skeleton) Canal system in sponges</p>	13
II	<p>CNIDARIA AND CTENOPHORA Type study: <i>Obelia</i>. (Structure – polyp and medusa and life cycle) Polymorphism in cnidarians. Corals and coral reefs Ctenophora (structure and affinities)</p>	10
III	<p>HELMINTHES AND ANNELIDA Type study: <i>Fasciola hepatica</i> (Structure, reproduction, life cycle and pathogenicity) Parasitic adaptations in helminthes Type study: <i>Ascarislumbricoides</i>(Structure, reproduction, life cycle and pathogenicity) Type study: <i>Hirudineria</i>(Structure, circulatory, excretory and reproductive systems) Coelom and coelomoducts in annelids</p>	17
IV	<p>ARTHROPODA AND MOLLUSCA Structural affinities of Onycophora Type study: <i>Macrobrachiumrosenbergii</i> (Structure, appendages and Respiratory system) Economic importance of insects (Beneficial – Lac insect, honey bee, <i>Bombyxmori</i> and Lady bird; Harmful – house fly, mosquito, locustand bedbug) Metamorphosis in insects Study of Pearl Oyster and Pearl Formation Torsion in gastropods</p>	14
V	<p>ECHINODERMATA AND HEMICHORDATA Water-vascular system Echinoderm larvae <i>Balanoglossus</i>- Structure and affinities</p>	6

TEXTBOOKS

1. R.L. Kotpal, *Modern Text Book of Zoology - Invertebrates*.
2. P.S. Dhami and J.K. Dhami *Invertebrate Zoology*.

SUGGESTED READINGS

1. L.H. Hyman, '*The Invertebrates*' Vol I, II and V. – M.C. Graw Hill Company Ltd.
2. Ruppert, Fox and Barnes, *Invertebrate Zoology - A Functional Evolutionary Approach* - Thomas Publishers. Indian Edition.
3. E.L. Jordan and P.S. Verma '*Invertebrate Zoology*' S. Chand and Company.
4. R.D. Barnes '*Invertebrate Zoology*' by: W.B. Saunders CO., 1986.
5. Barrington. E.J.W. '*Invertebrate Structure and Function*' by ELBS.
6. Sedgwick. A. '*A Student Text Book of Zoology*' Vol-I, II and III – Central Book Depot, Allahabad.
7. Parker.T.J. & Haswell '*A Text Book of Zoology*' by, W.A., Mac Millan Co. London.

Examples

Allen, T (1974) *Vanishing wildlife of North America*, Washington, D.C National Geographic Society

Encyclopedia & Dictionary

Examples:

Bergmann, P.G. (1993) *Relativity*. In *The new encyclopedia britannica* (Vol.26, pp.501-508).

Chicago: Encyclopedia Britannica.

TI Storer & EJ Boell (2007). *Encyclopedia of study of zoology* (Vol.3) Asiatic Publishing House.

Allaby Michael (2003). *Oxford Dictionary of Zoology*, Oxford University Press.

Magazine & News Paper articles

Examples:

Harlow, H.F (1983), *Fundamentals for preparing psychology journal articles*. *Journal of Comparative and Physiological psychology*, 55, 893-896.

Website or Webpage

Examples:

Devitt, T (2001, August 2) *Lightning injuries four at music festival The Why? Files*. Retrieved January 23, 2002, from <http://whyfiles.org/137/lightning/index.html>.

WEB LINKS OF SEMESTER I

Title of the paper: Animal Diversity Biology of Non – Chordates

Cours Code: ZOOT11A

UNIT 1

1.2 <https://youtu.be/86Vste5ETBA>

1.3 <https://youtu.be/2BbiClicXFU>

1.4 <https://youtu.be/ZP1ug26vvME>

1.5 <https://youtu.be/XmV18jr6X8A>

1.6 <https://youtu.be/yAG30gbVyZw>

UNIT 2

2.1 <https://youtu.be/RSRruxWSOPo>

2.2 <https://youtu.be/niClgqx80p4>

2.3 <https://youtu.be/0Pxai2x9QkI>

2.4 <https://youtu.be/IJZZAqL6Gn8>

UNIT 3

3.1 STRUCTURE <https://youtu.be/aU5Uyq03W4o>

REPRODUCTION <https://youtu.be/ZuEaz9WxOHM>

LIFE CYCLE <https://youtu.be/ZiOVjQAGzLs>

3.2 <https://youtu.be/y5SOdJqtbXU>

3.3 STRUCTURE <https://youtu.be/lZHUR8XxoZw>

REPRODUCTION <https://youtu.be/vycHOa9LQGI>

LIFE CYCLE <https://youtu.be/nBvnzxbxtNs>

PATHOGENECITY <https://youtu.be/tVkOFcPKN7A>

3.4 STRUCTURE https://youtu.be/VEz6BCm_6EY

CIRCULATORY SYS <https://youtu.be/W76ZjjgUsCM>

EXCRETORY SYS <https://youtu.be/GbqwP2VwwxY>

REPRODUCTIVE <https://youtu.be/sYS-cQ14aPg>

3.5 <https://youtu.be/euT3u3aCkIY>

UNIT 4

4.1. <https://youtu.be/6ufoVyzGCg>

4.2. STRUCTURE <https://youtu.be/aSXjOcaFB6w>

RESPIRATORY SYS <https://youtu.be/KEh-BiZwl6M>

4.3. <https://youtu.be/rIMZN53M1xg>

4.4. <https://youtu.be/e5wS19RXbSg>

4.5. https://youtu.be/t_h3tucvi3c

4.6. <https://youtu.be/feHLAGK3fiM>

UNIT 5

5.1. https://youtu.be/q7Uf_UsWVFs

5.2. <https://youtu.be/gwPG1K-2VD0>

5.3. <https://youtu.be/3YphuPakJr4>

CO-CURRICULAR ACTIVITIES

- Preparation of chart/model of *Elphidium* life cycle
- Visit to Zoology museum or Coral island as part of Zoological tour
- Charts on life cycle of *Obelia*, polymorphism, sponge spicules
- Clay models of canal system in sponges
- Preparation of charts on life cycles of *Fasciola* and *Ascaris*
- Visit to adopted village and conducting awareness campaign on diseases, to people as part of Social Responsibility.
- Plaster-of-Paris or Thermocol model of *Peripatus*
- Construction of a vermicompost in each college, manufacture of manure by students and donating to local farmers
- Models of compound eye, bee hive and termitarium (termitaria) by students
- Visit to apiculture centre and short-term training as part of apprenticeship programme of the govt. of Andhra Pradesh
- Chart on pearl forming layers using clay or Thermocol
- Visit to a pearl culture rearing industry/institute
- Live model of water vascular system
- Phylogeny chart on echinoderm larvae and their evolutionary significance
- Preparation of charts depicting the feeding mechanism, 3 coeloms, tornaria larva etc., of *Balanoglossus*

I SEMESTER END EXAMINATIONS

PAPER – I

MODEL PAPER

Cours Code: ZOOT11A

Title of the paper: Animal Diversity Biology of Non – Chordates

Time: 3 Hours

Max. Marks: 75

SECTION – A

Draw neat labeled diagrams wherever necessary.

Answer and FIVE of the following

5x5=25 Marks

- | | |
|--|----------|
| 1. Describe the structure of <i>Polystomella</i> | CO 1, L1 |
| 2. List out/state the different types of cells in sponges | CO1, L1 |
| 3. Describe <i>Obelia</i> medusa | CO1, L1 |
| 4. Describe Flame cells in <i>Fasciola hepatica</i> | CO1, L1 |
| 5. Explain the significance of coelom in annelids | CO2, L2 |
| 6. Explain bipinnaria larva in relation to phylogeny | CO3, L2 |
| 7. Explain the process of pearl formation and its significance | CO5, L2 |
| 8. <i>Peripatus</i> is a connecting link. Analyze. | CO4, L4 |

SECTION – B

Answer the following questions.

5X10=50 Marks

- | | |
|--|---------|
| 9. Explain the different types of nutrition in protozoans. | CO5, L2 |
| OR | |
| Explain the different types of canal system in sponges. | CO5, L2 |
| 10. Evaluate the process of metagenesis in the life cycle of <i>Obelia</i> . | CO1, L5 |
| OR | |
| Evaluate how ctenophores differ structurally from cnidarians. | CO1, L5 |
| 11. Describe the life cycle of <i>Ascaris lumbricoides</i> . | CO2, L2 |
| OR | |
| Describe the reproductive system of <i>Hirudinaria</i> . | CO2, L2 |
| 12. Enumerate the economic importance of insects | CO3, L1 |
| OR | |
| Describe torsion in gastropods as significant in larval development | CO3, L1 |
| 13. Analyze the functional suitability of water vascular system in echinoderms | CO5, L4 |
| OR | |
| Examine the structural affinities of <i>Balanoglossus</i> . | CO4, L4 |

PRACTICAL- I (At the end of I Semester)

Title of the paper: Animal Diversity Biology of Non – Chordates

No of Hours: 30

WEF: 2021-2022

Credits: 01

Course Code: ZOO P11A

LEARNING OUTCOMES:

By the end of the course students will be able to

1. Understand the general characters and classification from Protozoa to Hemichordata
2. Understand the importance of preservation of museum specimens
3. Identify animals based on special identifying characters
4. Understand different organ systems through demo or virtual dissections
5. Maintain a neat, labeled record of identified museum specimens
6. Exhibit the hidden creative talent

COURSE OUTCOMES

- CO1** To identify the characteristics and systematic position of protozoans and poriferans PO1, PO2, PO5, PO6, PO7, PSO1
- CO2** To identify the characteristics and systematic position of Cnidarians and Helmenthes. PO1, PO2, PO5, PO6, PO7, PSO1
- CO3** To identify the characteristics and systematic position of Annelids, Arthropodans and Molluscans. PO1, PO2, PO5, PO6, PO7, PSO1
- CO4** To identify the characteristics and systematic position of Echinoderms and hemichordates. PO1, PO2, PO5, PO6, PO7, PSO1
- CO5** To understand the various systems of Prawn by Dissecting and Mounting its appendages. PO1, PO2, PO5, PO6, PO7, PSO1

Syllabus
Course Details

Unit	Learning Units
Syllabus	General characters and classification of the following phyla and sub-phyla up to classes with suitable examples: Protozoa, Porifera, Cnidaria, Platyhelminthes, Nematoda, Annelida, Arthropoda, Mollusca, Echinodermata and Hemichordata.
I	<p>SPOTTERS</p> <p>Porifera: <i>Euspongia, Spongilla, Sycon</i>.</p> <p>Cnidaria: <i>Physalia, Velella, Aurelia, Gorgonia, Pennatula</i>.</p> <p>Annelida: <i>Nereis, Heteronereis, Aphrodite, Hirudineria</i>.</p> <p>Arthropoda: <i>Scylla, Macrobrachium, Scolopendra, Sacculina, Limulus, Scorpion, Peripatus</i>.</p> <p>Mollusca: <i>Chiton, Murex, Unio, Sepia, Loligo, Octopus, Nautilus</i>.</p> <p>Echinodermata: <i>Asterias, Ophiothrix, Echinus, Clypeaster, Cucumaria, Antedon</i>.</p> <p>Hemichordata: <i>Balanoglossus</i></p>
II	<p><u>SLIDES</u></p> <p>Protozoa: <i>Elphidium, Paramoecium, Paramoecium</i> - Binary fission and conjugation, <i>Vorticella, Entamoebahistolytica, Plasmodium vivax</i></p> <p>Porifera: T.S and L.S. of <i>Sycon</i>, spicules, gemmule</p> <p>Cnidaria: <i>Obeliacolony</i> and medusa,</p> <p>Platyhelminthes: <i>Planaria, Fasciola hepatica, Fasciolalarval forms (Miracidium, Redia, Cercaria) Echinococcus granulosus, Taeniasolium</i></p> <p>Nematoda: <i>Ascaris lumbricoides</i> (male and female), <i>Ancylostomaduodenale</i> (male and female), <i>Dracunculus, Wuchereria</i></p> <p>Annelida: Trochophore larva</p> <p>Arthropoda: Mouthparts of housefly, butter fly, male and female <i>Anopheles</i> and <i>Culex</i>, Crustacean larvae (nauplius, mysis, zoea)</p> <p>Mollusca: Glochidium larva</p> <p>Echinodermata: Bipinnarialarva</p> <p>Hemichordata: Tornaria larva</p>
III	<p><u>DEMONSTRATION OF DISSECTIONS</u></p> <p>1. Prawn: Nervous system Mounting of statocyst Mounting of appendages</p> <p>2. Mounting of Insect mouth parts</p> <ul style="list-style-type: none"> • Animal Album to be submitted at the time of practical examination • Laboratory Record Book to be submitted at the time of practical examination

Suggested Manuals

1. Practical Zoology- Invertebrates S.S.Lal
2. Practical Zoology - Invertebrates P.S.Verma
3. Practical Zoology K.P.Kurl

I B.Sc. ZOOLOGY PRACTICAL EXAMINATION

Practical - I

Course Code: ZOO P11A

Title of the paper: Animal Diversity Biology of Non – Chordates

Time: 3hrs.

Max. Marks 40M

-
1. List out the general characters of Phylum ----- . CO1 L1 3 M
2. Identify and draw a neat labeled diagram of nervous system/appendages of prawn. 7 M
 CO 4 L3 Identification: 1 M
 Diagram: 4 M
 Labeling: 2 M
2. Prepare a neat mount of statocyst/ mouth parts of cockroach. 5 M
 CO4 L3 Mounting: 2 M
 Diagram: 1 M
 Labeling: 2 M
3. Identify, draw a labeled diagram, classify and write notes on A, B, C, D and E 5 X 3 = 15 M
 CO3 L2
 A. Protozoa & Porifera
 B. Cnidaria & Platyhelminthes
 C. Nematoda & Annelida
 D. Arthropoda
 E. Mollusca, Echinodermata & Hemichordata
- Identification: 1 M
 Diagram: ½ M
 Classification: ½ M
 Comments: 1 M
4. Practical Record Book CO5 L3 5 M
5. VIVA CO6 L5 5M

Total Marks :- 40M

**ADUSUMILLI GOPALAKRISHNAIAH & SUGAR CANE GROWERS SIDDHARTHA DEGREE COLLEGE
OF ARTS & SCIENCE, VUYYURU-521165, KRISHNA Dt., A.P. (AUTONOMOUS).**

NACC reaccredited at 'A' level
Autonomous –ISO 9001-2015 Certified

Title of the Paper: **Cell Biology, Genetics, Molecular Biology & Evolution**

Semester: - III

Course Code	<i>ZOO-301</i>	Course Delivery Method	Class Room/Blended Mode - Both
Credits	3	CIA Marks	30
No. of Lecture Hours/ Week	4	Semester End Exam Marks	70
Total Number of Lecture Hours	60	Total Marks	100
Year of Introduction : 2017-18	Year of Offering 2021-2022	Year of Revision – 2021-22	Percentage of Revision: 0%

Course Outcomes:

The overall course outcome is that the student shall develop deeper understanding of what life is and how it functions at cellular level. This course will provide students with a deep knowledge in Cell Biology, Animal Biotechnology and Evolution and by the completion of the course the graduate shall be able to –

- CO1 To understand the basic unit of the living organisms and to differentiate the organisms by their cell structure.
- CO2 Describe fine structure and function of plasma membrane and different cell organelles of eukaryotic cell.
- CO3 To understand the history of origin of branch of genetics, gain knowledge on heredity, interaction of genes, various types of inheritance patterns existing in animals
- CO4 Acquiring in-depth knowledge on various aspects of genetics involved in sex determination, human karyotyping and mutations of chromosomes resulting in various disorders
- CO5 Understand the central dogma of molecular biology and flow of genetic information from DNA to proteins.
- CO6 Understand the principles and forces of evolution of life on earth, the process of evolution of new species and apply the same to develop new and advanced varieties of animals for the benefit of the society

Learning Objectives

- To understand the origin of cell and distinguish between prokaryotic and eukaryotic cell
- To understand the role of different cell organelles in maintenance of life activities
- To provide the history and basic concepts of heredity, variations and gene interaction
- To enable the students distinguish between polygenic, sex-linked, and multiple allelic modes of inheritance.
- To acquaint student with basic concepts of molecular biology as to how characters are expressed with a coordinated functioning of replication, transcription and translation in all living beings
- To provide knowledge on origin of life, theories and forces of evolution
- To understand the role of variations and mutations in evolution of organisms

Syllabus
Course Details

Unit	Learning Units	Lecture Hours
I	<p>Unit – I Cell Biology Definition, history, prokaryotic and eukaryotic cells, virus, viroids, mycoplasma Electron microscopic structure of animal cell. Plasma membrane –Models and transport functions of plasma membrane. Structure and functions of Golgi complex, Endoplasmic Reticulum and Lysosomes Structure and functions of Ribosomes, Mitochondria, Nucleus, Chromosomes (Note: 1. General pattern of study of each cell organelle – Discovery, Occurrence, Number, Origin Structure and Functions with suitable diagrams) 2. Need not study cellular respiration under mitochondrial functions)</p>	10
II	<p>Unit – II Genetics – I Mendel’s work on transmission of traits Gene Interaction – Incomplete Dominance, Codominance, Lethal Genes Polygenes (General Characteristics & examples); Multiple Alleles (General Characteristics and Blood group inheritance Sex determination (Chromosomal, Genic Balance, Hormonal, Environmental and Haplo-diploidy types of sex determination) Sex linked inheritance (X-linked, Y-linked & XY-linked inheritance)</p>	13
III	<p>Unit – III Genetics – II Mutations & Mutagenesis Chromosomal Disorders (Autosomal and Allosomal) Human Genetics – Karyotyping, Pedigree Analysis (basics) Basics on Genomics and Proteomics</p>	10
IV	<p>UNIT IV: Molecular Biology Central Dogma of Molecular Biology Basic concepts of – a. DNA replication – Overview (Semi-conservative mechanism, Semi-discontinuous mode, Origin & Propagation of replication fork) b. Transcription in prokaryotes – Initiation, Elongation and Termination, Post-transcriptional modifications (basics) c. Translation – Initiation, Elongation and Termination Gene Expression in prokaryotes (Lac Operon); Gene Expression in eukaryotes</p>	15
V	<p>Unit – V Origin of life Theories of Evolution: Lamarckism, Darwinism, Germ Plasm Theory, Mutation Theory. Neo-Darwinism: Modern Synthetic Theory of Evolution, Hardy-Weinberg Equilibrium. Forces of Evolution: Isolating mechanisms, Genetic Drift, Natural Selection, and Speciation.</p>	12

**A.G. & S.G.Siddhartha Degree College of Arts & Science, Vuyyuru – 521165, Krishna Dt.
A.P. (Autonomous)**

Semester III
(Model question paper)

w.e.f. 2021-2022

Title of the paper: Cell Biology, Genetics, Molecular Biology & Evolution
Time: 3hrs.

Code – ZOO-301C
max.marks: 70

Section – A

4 x 5= 20.

Answer any **four** questions. Each question carries **five** marks. Draw neat labeled diagrams wherever necessary.

1. Golgi complex
2. Nucleus,
3. Lethal Genes
4. Sex determination
5. Mutations
6. Proteomics
7. Semi-conservative mechanism
8. Hardy-WeinbergEquilibrium

Section – B

5 x 10 =50.

Answer any **five** questions. Each question carries **Ten** marks. Draw neat labeled diagrams wherever necessary.

9. Explain the Models and transport functions of Plasma membrane?
10. Structure and functions of Mitochondria?
11. Explain about Sex linked inheritance?
12. Give an account of Chromosomal Disorders?
13. Explain about Translation?
14. Write an essay on Gene Expression in prokaryotes?
15. Explain about theory of Lamarckism &Darwinism?
- 16 Write an essay on Speciation?

**A.G. & S.G. Siddhartha Degree College of Arts & Science, Vuyyuru – 521165,
Krishna Dt. A.P. (Autonomous)**

**Semester -III
Guide lines to the Paper Setter.**

Title of the paper: Cell Biology, Genetics, Molecular Biology & Evolution **W.e.f. 2021-2022**
Code – ZOO-301C

Time: 3hrs.

Max. Marks: 70.

1. Answer any **four** questions out of eight in Section – A. Each question carries five marks. 4x5 = 20M.
2. Answer any **five** questions out of eight in Section – B. Each question carries Ten marks. 5x10= 50M.

	Section	UNIT-I	UNIT-II	UNIT-III	UNIT-IV	UNIT-V
5 Marks Questions	A	2	2	2	1	1
10 Marks Questions	B	2	1	1	2	2
Weightage		30	25	20	25	25

Note: 1. please provide the scheme of valuation for the paper.

2. Question paper should be in English medium.

REFERENCES:

1. Lodish, Berk, Zipursky, Matsudaria, Baltimore, Darnell 'Molecular Cell Biology' W.H.Freeman and company New York.
2. Cell Biology by De Robertis
3. Bruce Alberts, Molecular Biology of the Cell
4. Rastogi, Cytology
5. Varma & Aggarwal, Cell Biology
6. C.B. Pawar, Cell Biology
7. Gardner, E.J., Simmons, M.J., Snustad, D.P. (2008).Principles of Genetics. VIII Edition. Wiley India.
8. Snustad, D.P., Simmons, M.J. (2009). Principles of Genetics. V Edition. John Wiley and Sons Inc.
9. Klug, W.S., Cummings, M.R., Spencer, C.A. (2012). Concepts of Genetics. X Edition. Benjamin Cummings.
10. Russell, P. J. (2009). Genetics- A Molecular Approach. III Edition. Benjamin Cummings.
11. Griffiths, A.J.F., Wessler, S.R., Lewontin, R.C. and Carroll, S.B. Introduction to Genetic Analysis. IX Edition. W. H. Freeman and Co.
12. Ridley, M. (2004). Evolution. III Edition. Blackwell Publishing
13. Molecular Biology by freifielder
14. Instant Notes in Molecular Biology by Bios scientific publishers and Viva Books Private Limited
15. Hall, B. K. and Hallgrimsson, B. (2008). Evolution. IV Edition. Jones and Bartlett Publishers
16. Campbell, N. A. and Reece J. B. (2011). Biology. IX Edition, Pearson, Benjamin, Cummings.
17. Douglas, J. Futuyma (1997). Evolutionary Biology. Sinauer Associates.
18. Minkoff, E. (1983). Evolutionary Biology. Addison-Wesley.
19. James D. Watson, Nancy H. Hopkins 'Molecular Biology of the Gene'
20. Jan M. Savage. Evolution, 2nd ed, Oxford and IBH Publishing Co., New Delhi.
21. Gupta P.K., 'Genetics

PRACTICAL - III

Code: ZOO- 301P
(2hrs/week)

Cell Biology, Genetics, Molecular Biology & Evolution
PRACTICAL SYLLABUS

w.e.f. 2021-2022.
MAX.MARKS: 50.

Learning Objectives:

- Acquainting and skill enhancement in the usage of laboratory microscope
- Hands-on experience of different phases of cell division by experimentation
- Develop skills on human karyotyping and identification of chromosomal disorders
- To apply the basic concept of inheritance for applied research
- To get familiar with phylogeny and geological history of origin & evolution of animals

Syllabus
Course Details

Unit	Learning Units
I	I.Cell Biology 1. Preparation of temporary slides of Mitotic divisions with onion root tips 2. Observation of various stages of Mitosis and Meiosis with prepared slides 3. Mounting of salivary gland chromosomes of <i>Chironomus</i>
II	II. Genetics 1. Study of Mendelian inheritance using suitable examples and problems 2. Problems on blood group inheritance and sex linked inheritance 3. Study of human karyotypes (Down's syndrome, Edwards, syndrome, Patau syndrome, Turner's syndrome and Klinefelter syndrome)
III	III. Evolution 1. Study of fossil evidences 2. Study of homology and analogy from suitable specimens and pictures 3. Phylogeny of horse with pictures 4. Study of Genetic Drift by using examples of Darwin's finches (pictures) 5. Visit to Natural History Museum and submission of report

**A. G & S. G. S. DEGREE COLLEGE OF ARTS & SCIENCE, VUYYURU 521165, KRISHNA Dt.,
A.P. (AUTONOMOUS)
PAPER – III**

(Cell Biology, Genetics, Molecular Biology & Evolution)

w.e.f.2021-22.

Model Question paper (External)

Max.Marks: 25 M.
Paper Code: ZOO-301P

I. Cell Biology

1. Identify, draw neat labeled diagram & notes of the following stages. 2x2 ¹/₂= 5M.
A & B

II. Genetics

1. Genetics Problem. 5M.
2. Identify the following Chromosomes & Comment. 2x2 ¹/₂= 5M.
A & B

III. Evolution

1. Identify the given pictures and write the Comment. 2x2 ¹/₂= 5M
A & B
2. Identify the given pictures and Comment. 2x2 ¹/₂= 5M
A & B

**A. G.& S.G. SIDDHARTHA DEGREE COLLEGE OF ARTS & SCIENCE, VUYYURU-521165
ZOOLOGY PRACTICAL -III
(INTERNAL)**

**w.e.f. 2021-2022.
(2hrs/week).**

Cell Biology, Genetics, Molecular Biology & Evolution

Code: ZOO-301P.

Max.marks:25M.

Time: 3hrs.

1. Attendance ----- 5M.
2. Record ----- 10M.
3. Field trip & Field note book -----10M.

Total ----- 25M.

A. G & S. G. S. DEGREE COLLEGE OF ARTS & SCIENCE, VUYYURU 521165, KRISHNA Dt., A.P.
(AUTONOMOUS)
PAPER – III

Guide lines for the practical Examiner

W.e.f.2021-2022

Class: II B.Z.C

Paper Title: **(Cell Biology, Genetics, Molecular Biology & Evolution)**

Paper Code: ZOO-301P

Max.Marks: 25 M.

I.Cytology

1. Slide A from Mitosis & Slide B Meiosis. 2x2 ¹/₂= 5M.
(¹/₂ mark for identification, 1 mark for labeled diagram & 1 mark for comments)

II.Genetics

2. Checker board 2M.
Explanation 3M.
3. Identify & Comment on A& B (From Chromosomes). 2x2 ¹/₂= 5M
A-Identification – 1 M, Comment – 1¹/₂ M
B-Identification – 1 M, Comment – 1¹/₂ M

III.Evolution

4. Identify & Comment on A& B (A- fossil evidence, B – Homology & Analogy) 2x2 ¹/₂= 5M
A-Identification – 1 M, Comment – 1¹/₂ M
B-Identification – 1 M, Comment – 1¹/₂ M
5. Identify & Comment on A& B (A- Phylogeny of Horse, B – Darwin's Finches) 2x2 ¹/₂= 5M
A-Identification – 1 M, Comment – 1¹/₂ M
B-Identification – 1 M, Comment – 1¹/₂ M

**ADUSUMILLI GOPALAKRISHNAIAH & SUGAR CANE GROWERS SIDDHARTHA DEGREE COLLEGE
OF ARTS & SCIENCE, VUYYURU-521165, KRISHNA Dt., A.P. (AUTONOMOUS).**

NACC reaccredited at 'A' level
Autonomous –ISO 9001-2015 Certified

Title of the Paper: Animal Biotechnology

Semester: - V

Course Code	ZOO-501	Course Delivery Method	Class Room/Blended Mode - Both
Credits	3	CIA Marks	30
No. of Lecture Hours/ Week	4	Semester End Exam Marks	70
Total Number of Lecture Hours	60	Total Marks	100
Year of Introduction : 2017-18	Year of Offering 2021-2022	Year of Revision – 2021-22	Percentage of Revision: 0%

Objective of the course: To educate students on various biotechnological techniques involve in animal biotechnology, gene manipulations, their role in production of medicines and transgenic animals.

Course outcomes:

CO1 Students are made to become aware of the use of technology that is involved in cloning.

CO2 Improved quality of species with gene manipulations

CO3 Recent development in biotechnology that helps for better environment and Production of various monoclonal antibodies and vaccines.

CO4 Formation of different species - transgenic animals

CO5 Resistant variety and better yield

Learning Objectives

- To understand the natural function of Restriction enzymes and explained how they are used in r-DNA technology.
- To understand the features & Types of cloning vectors.
- Purposes and applications of r-DNA techniques.
- To understand uses of DNA probes.
To understand gene transfer technologies for animals and animal cell lines.
- Explain how the creation of sticky ends by restriction enzymes in use full in producing a r-DNA technologies.
- To understand the process of nucleic acid hybridization .

Syllabus
Course Details

Unit	Learning Units	Lecture Hours
I	<p>Unit 1: Tools of Recombinant DNA technology - Enzymes and Vectors Restriction modification systems : Types I, II and III- Nomenclature, Applications of Type II restriction enzymes in genetic engineering ,DNA polymerases, transferase, kinases and phosphatases,and DNA ligases Cloning Vectors: : Properties of Cloning Vectors Plasmid vectors:pBR and pUC 18, Bacteriophage and, Cosmids.Artificial Chromosome Vectors: BACs, YACs</p>	15
II	<p>Unit 2: Techniques of Recombinant DNA technology Cloning: Procedure of gene cloning, Use of linkers and adaptors. Microinjection, electroporation, biolistic method (gene gun). PCR:- Basics of PCR, Principle and Procedure of PCR. DNA Sequencing: Sanger’s method of DNA sequencing- traditional and automated sequencing. Southern, Northern and Western blotting. DNA finger printing,</p>	15
III	<p>UNIT 3 Animal Cell Technology Cell culture media: Natural and Synthetic, Types Cell cultures-: primary culture, secondary culture. Continuous cell lines , Established Cell lines (common examples such as MRC, HeLa, CHO, BHK,) Cryopreservation of cultures, Hybridoma Technology:- Cell fusion, Production of Monoclonal antibodies (mAb), Applications of mAb Stem cells: Types of stem cells- Embryonic and Adult Stem Cells, Diabetes and Parkinson’s diseases.</p>	10
IV	<p>Unit 4: Reproductive Technologies & Transgenic Animals Manipulation of reproduction in animals, Artificial Insemination, <i>In vitro</i> fertilization. Super ovulation, Embryo transfer, Embryo cloning. Transgenic Animals- Production of Transgenic Animals- sheep, fish.</p>	10
V	<p>Unit 5: Applied Biotechnology Industry: Fermentation- Different types of Fermentation. Submerged & Solid state, batch, Fed batch & Continuous (Short notes only) Downstream processing - Filtration, centrifugation, chromatography, spray drying , Fisheries: Polyploidy in fishes.</p>	10

SEMESTER-V (Model Question paper)

w.e.f.- 2021-2022.

Paper Title: Animal Biotechnology.

Paper Code: ZOO 501C

Time: 3 hrs.

Max.Marks:70

.....
Part – A

Answer **any FOUR** questions out of eight in Part - A. Each question carries five marks. **4 X 5 = 20**

Part – B

1. Ligases
2. YAC
3. Southern Blotting
4. DNA Fingerprinting
5. Applications of mAb
6. Polyploidy in fishes
7. Invitro fertilization
8. Chromatography

Part – B

Answer **any FIVE** questions out of eight in Part - B .Each question carries Ten marks. **5 X 10 = 50**

9. Write an essay on cloning vectors.
10. Explain the role of Type II Restriction enzymes in genetic engineering.
11. Define gene cloning .Describe the procedure of gene cloning in detail.
12. What is PCR. Briefly describe various steps of PCR.
13. Define Stem Cell Technology ? Briefly describe about it.
14. Write in detail about the transgenic animals.
15. Write an essay on different types of fermentation.
16. Briefly describe the technology of super ovulation and Embryo transfer in cattle's and discuss their applications and limitations.

SEMESTER-V

Time: 3 hrs

Max.Marks:70

Guide lines to the paper setter

Paper Title: Animal Biotechnology

Paper Code: ZOO -501C

Note: 1. Answer **any FOUR** questions out of eight in Part-A . Each question carries five marks. 4X 5 = 20M.

2. Answer any **FIVE** questions out of eight in Part-B . Each question carries 10 marks. 5 X 10 = 50M.

	PART	Unit – I	Unit – II	Unit – III	Unit – IV	Unit – V
5 Marks Questions	A	2	2	1	1	2
10 Marks Questions	B	2	2	1	2	1
Weightage		30	30	15	25	20

- Note:**
1. please provide the scheme of valuation for the paper.
 2. Question paper should be both in English and Telugu media.

Reference Books:-

1. Brown TA. (2010). Gene Cloning and DNA Analysis. 6th edition. Blackwell Publishing , Oxford,U.K
2. Clark DP and Pazdernik NJ. (2009). Biotechnology: Applying the Genetic Revolution. ElsevierAcademic Press, USA
3. Primrose SB and Twyman RM. (2006). Principles of Gene Manipulation and Genomics, 7th edition. Blackwell Publishing, Oxford, U.K.

ZOOLOGY PRACTICAL SYLLABUS

PAPER - V

Periods: 30

Code: ZOO-501P

Credits :2

Paper Title : Animal Biotechnology

Max.Marks:50

Unit	Learning Units
SYLLABUS	1. Genomic DNA isolation from <i>E. coli</i> .
	2. Plasmid DNA isolation (pUC 18/19) from <i>E. coli</i>
	3. Study the following techniques through photographs. a. Southern blotting. b. Western blotting. c. DNA sequencing (Sanger's method) d. DNA finger printing
	4. PCR (demonstration) on site or of site demonstration
	5. Project report on animal cell culture

A.G & S. G.S.DEGREE COLLEGE OF ARTS & SCIENCE, VUYYURU - 521165, KRISHNA Dt., A.P.
(AUTONOMOUS)

Practical - V

w.e.f. 2021- 22

(Animal Biotechnology)

Max. Marks: 25

Model Question Paper (External)

Paper Code: ZOO-501P

1. Identify the following Genomic DNA isolation from <i>E. coli</i> .	5m
2. Identify the following Plasmid DNA isolation (pUC 18/19) from <i>E. coli</i> .	5m
3. Study the following techniques given on photographs & Write notes on. A & B	2x5=10
4. PCR (demonstration) on site or of site demonstration.	5m
Total:	25m

Guide lines for the Practical Examiners.

Class: III B.Z.C

Paper Title: Animal Biotechnology.

W.e.f.2021-22.

Max.Marks: 25 M.

Paper Code: ZOO-501C

-
1. Identify the following Genomic DNA isolation from *E. coli*.
(5 marks for Procedure)
 2. Identify the following Plasmid DNA isolation (pUC 18/19) from *E. coli* .
(5 marks for Procedure)
 3. Study the following techniques given on photographs & Write notes on A & B.
(1 mark for identification & 4 marks for diagram and notes, for each photographs)
 4. PCR (demonstration) on site or of site demonstration.
(5 marks for PCR demonstration)

A.G & S. G.S.DEGREE COLLEGE OF ARTS & SCIENCE, VUYURU - 521165, KRISHNA Dt., A.P.
(AUTONOMOUS)

Practical – V
(Animal Biotechnology)
Model Question Paper (Internal)

w.e.f. 2021-22
Max. Marks: 25
Paper Code: ZOO-501P

1. Attendance	--	5 M
2. Record	--	10M
3. Field trip & Field note book	--	10M

Total -- 25M

**ADUSUMILLI GOPALAKRISHNAIAH & SUGAR CANE GROWERS SIDDHARTHA DEGREE COLLEGE
OF ARTS & SCIENCE, VUYYURU-521165, KRISHNA Dt., A.P. (AUTONOMOUS).**

NACC reaccredited at 'A' level
Autonomous –ISO 9001-2015 Certified

Title of the Paper: Animal Husbandry

Semester: - V

Course Code	ZOO-502	Course Delivery Method	Class Room/Blended Mode - Both
Credits	3	CIA Marks	30
No. of Lecture Hours/ Week	4	Semester End Exam Marks	70
Total Number of Lecture Hours	60	Total Marks	100
Year of Introduction : 2017-18	Year of Offering 2021-2022	Year of Revision – 2021-22	Percentage of Revision: 0%

Objective of the course: To help students to stand on their own legs, acquire skills in poultry and Dairy farms and to set up their own firms.

Course outcomes:

CO1; Students are given awareness about different varieties of chicks.

CO2: Students are familiarized with recent technologies those are applied to produce different species with variations which are more beneficial and income fetching.

CO3: Students with the help of self help schemes, can set up their own firms, and provide

CO4: Employability to others and to tap the resources of Government and Non governmental sectors.

CO5: They are given managerial and marketing skills as well.

Learning Objectives

- To understand production of milk, meat, egg and other animal bi – products.
- To understand delivery of necessary livestock health care through timely immunization against total diseases, proper diagnosis and rational treatment for optimization of livestock production.
- To understand fulfil the objective of protein enriched quality food requirement of the growing population of the country and prevent malnutrition in one the highest malnourished children population in the world.
- To understand principles of feeding and nutrient requirements for different stages of layers and broilers.
- To make available quality concentrated animals feed to the cattle, buffalo, sheep and poultry to provide balanced ration at affordable prices.

Syllabus

Course details

Unit	Learning Units	Lecture Hours
I	<p>UNIT – I: General introduction to poultry farming, Principles of poultry housing. Poultry houses. Systems of poultry farming. Management of chicks, growers, layers, and Broilers.</p>	10
II	<p>UNIT – II: Poultry feed management – Principles of feeding. Nutrient requirements for different stages of layers and broilers. Methods of feeding- Whole grain feeding system, Grain and mash method, All mash method, Pellet feeding. Poultry diseases – viral, bacterial, fungal and parasitic (two each); symptoms, control and management.</p>	10
III	<p>UNIT – III: Selection, care and handling of hatching eggs, Egg testing. Methods of hatching. Brooding and rearing, Sexing of chicks.</p>	10
IV	<p>UNIT- IV: Breeds of Dairy Cattle and Buffaloes – Definition of breed; Classification of Indian Cattle breeds, exotic breeds and Indian buffalo breeds. Systems of inbreeding and crossbreeding. Housing of dairy animals – Selection of site for dairy farm; systems of housing – loose, housing system. Conventional dairy barn.</p>	20
V	<p>UNIT - V: Care and management of dairy animals - Care and management of calf, heifer, milk animal, dry and pregnant animal, bulls and bullocks. Cleaning and sanitation of programme. Records to be maintained in a dairy farm.</p>	10

Part – A

Answer **any FOUR** questions out of eight in Part - A . Each question carries five marks. **4 X 5 = 20**

1. Principles of poultry farming.
2. Chick management.
3. Poultry feed management.
4. Marek's disease.
5. Egg testing (Candle test)
6. Cleaning and sanitation of Dairy farm.
7. Milk record register
8. Loose housing system

Part – B

Answer **any five** questions out of eight in Part - B .Each question carries Ten marks. **5 X 10 = 50**

9. Write an essay on systems of poultry farming
10. Write an essay on management of Broilers
11. Write an essay on symptoms control and management of two viral and bacterial diseases.
12. Write an essay on methods of feeding in Poultry
13. Write an essay on different methods of hatching eggs
14. Give an account of breeds of Indian Cows
15. Explain the vaccination programme in Cattle
16. Write an essay on care and management of Calf, heifer and milk animals

SEMESTER-V

Time: 3 hrs

Max.Marks:70

Guide lines to the paper setter

Paper Title: Animal Husbandry.

Paper Code: 502C

Note: 1. Answer **any FOUR** questions out of eight in Part-A . Each question carries five marks. 4 X 5 = 20M.

2. Answer any **five** questions out of eight in Part-B . Each question carries 10 marks. 5 X 10 = 50M.

	PART	Unit – I	Unit – II	Unit – III	Unit – IV	Unit – V
5 Marks Questions	A	2	2	1	2	1
10 Marks Questions	B	2	2	1	2	1
Weightage		30	30	15	30	15

Note: 1. please provide the scheme of valuation for the paper.

2. Question paper should be both in English and Telugu media.

Text Books:-

1. Animal Husbandry: ---- Technical Test paper.
2. Poultry- Technical Revised Common Core.
3. Animal Husbandry --- Dr.K.Kondaiah, A.V.N.Gupta.

ZOOLOGY PRACTICAL SYLLABUS

Period: 30

PAPER – VI

Credits: 2

Paper Code: Zoo-502P

Paper Title: Animal Husbandry

Max.Marks:50

Unit	Learning Units
SYLLABUS	1. Study of various breeds of layers and broilers (photographs)
	2. Identification of disease causing organisms in poultry birds (as per theory)
	3. Study of the anatomy of a poultry bird by way of dissecting a bird. (Demonstration)
	4. Study of various activities in a poultry farm (layers and broilers) and submission of a report.
	5. Study of various breeds of cattle (photographs/microfilms)
	6. Study of various activities carried out in a dairy farm and submission of a report.

*

A.G & S. G.S.DEGREE COLLEGE OF ARTS & SCIENCE, VUYYURU - 521165, KRISHNA Dt., A.P. (AUTONOMOUS)

*Practical - VI
(Animal Husbandry)*

*w.e.f. 2021 -22
Max. Marks: 50*

Model Question Paper (External)

Paper Code: ZOO-502P

1. Study of various breeds of layers and broilers (photographs) A & B	2X2 ¹ / ₂ =5M
2. Identification of disease causing organisms in poultry birds (as per theory) A & B	2X2 ¹ / ₂ =5M
3. Study of the anatomy of a poultry bird by way of dissecting a bird. (Demonstration)	5M
4. Study of various breeds of cattle (photographs/microfilms) A & B	2X5=10M
	Total -- 25M

**A.G & S. G.S.DEGREE COLLEGE OF ARTS & SCIENCE, VUYURU - 521165, KRISHNA Dt., A.P.
(AUTONOMOUS)**

W.e.f.2021-22.
Max.Marks: 25m
Paper Code: ZOO-502C

Guide lines for the Practical Examiners.

Class: III B.Z.C
Paper Title: (Animal Husbandry)

1. Identify and comment on A & B (Charts / Photographs).
(Identification - $\frac{1}{2}$ mark & Comments -2m)
2. Identify and comment on A & B (Charts / Photographs)
(Identification - $\frac{1}{2}$ mark & Comments -2m)
3. Demonstration: (4 marks for diagram & 1 mark for labeling)
4. Identify and comment on A & B (Photographs/ microfilms).
(Identification -1 mark & Comments -4m)

A.G & S. G.S.DEGREE COLLEGE OF ARTS & SCIENCE, VUYURU - 521165, KRISHNA Dt., A.P. (AUTONOMOUS)

*Practical - V I
(Animal Husbandry)*

*w.e.f. 2021 - 22
Max. Marks: 50*

Model Question Paper (Internal)

Paper Code: ZOO-502P

1. Attendance	--	5 M
2. Record	--	10M
3. Field trip & Field note book (Any one)	--	10M
	Total --	25M

AG & SG SIDDHARTHA DEGREE COLLEGE OF ARTS & SCIENCE

**Vuyyuru – 521165, Krishna District, A.P.
Re-Accredited by NAAC 'A' Grade
Autonomous College**



DEPARTMENT OF COMPUTER SCIENCE

Minutes of the meeting of Board of Studies

10-11-2021

Minutes of the meeting of Board of Studies in Computer Science for Semester I, III & V of I, II & III years B.Sc. (MPCs, MCCs, MSCs), B.Com. (C.A.) and B.Com (e-Commerce) Life Skill Course and Skill Development Course of AG & SG Siddhartha Degree College of Arts & Science, Vuyyuru, held at 9.30 A.M on 10-11-2021 in the Department of Computer Science.

Sri T.NagaPrasadaRao ... Presiding

Members Present:

- | | | |
|-------------------------|----------------------|--|
| 1)..... | Chairman | Head, Department of Computer Science,
AG & SG Siddhartha Degree College of Arts & Science. |
| (T.NagaPrasadaRao) | | |
| 2) ----- | University
Nomine | Principal, Krishna University College of Engineering
and Technology, Machilipatnam. |
| (Dr. M. Babu Reddy) | | |
| 3). ----- | Subject
Expert | Head, Department of Computer Science
A.N.R College Gudivada. |
| (Dr. P. J. S Kumar) | | |
| 4) ----- | Subject
Expert | Deputy Head, Department of Computer Science
PB Siddhartha College of Arts & Science,
Vijayawada. |
| (Mr. K. Sridhar) | | |
| 5) ----- | Industrial
Expert | .Net Developer, Maven Soft System Pvt. Ltd
Madaapur, Hyderabad. |
| (R. Sowjanya) | | |
| 6)..... | Member | Lecturer in Computer Science, AG & SG Siddhartha
Degree College of Arts & Science, Vuyyuru |
| (T. Keerthi) | | |
| 7)..... | Member | Lecturer in Computer Science, AG & SG Siddhartha
Degree College of Arts & Science, Vuyyuru-521165. |
| (K Srikanth) | | |
| 8)..... | Member | Lecturer in Computer Science, AG & SG Siddhartha
Degree College of Arts & Science, Vuyyuru-521165 |
| (S.Prabhavathi) | | |
| 9)..... | Member | Lecturer in Computer Science, AG & SG Siddhartha
Degree College of Arts & Science, Vuyyuru-521165 |
| (A. Sravani) | | |
| 10)...... | Member | Lecturer in Computer Science, AG & SG Siddhartha
Degree College of Arts & Science, Vuyyuru-521165 |
| (V.N.MalleswraRao) | | |
| 11)..... | Member | Lecturer in Computer Science, AG & SG Siddhartha
Degree College of Arts & Science, Vuyyuru-521165 |
| (A. Naga Srinivasa Rao) | | |
| 12)..... | Member | Lecturer in Computer Science, AG & SG Siddhartha
Degree College of Arts & Science, Vuyyuru-521165 |
| (V. Munni) | | |
| 13) ----- | Member | Student in M.Sc. Computer Science, AG& SG Siddhartha
Degree College of Arts & Science, Vuyyuru-521165 |
| (K. Rajya Lakshmi) | | |
| 14) ----- | Member | Student in B.Sc. Computer Science, AG& SG Siddhartha
Degree College of Arts & Science, Vuyyuru-521165 |
| (M. Jyothi) | | |

BOS Meeting – U.G Department Computer Science-10/11/2021, 9.30 AM, through online Mode (Google Meet) A.G& S.G Siddhartha Degree College of Arts & Science.

Syllabus approval letter through Mail

1. Associate Professor Dr. M. Babu Reddy,

Dear Sir,

Herewith, I am approving the Minutes of BOS meeting...

Please treat this email as my formal approval of minutes..

Dr. M. Babu Reddy

Principal, Krishna University College of Engineering & Technology

Machilipatnam.

Mobile No 9963436460.

e-mail id:m_babureddy@yahoo.com

Agenda for B.O.S Meeting.

1. To Discuss and approve the Structure and Syllabi, Model Question Paper for first Semester of B.Sc.(MPCs, MCCs.MSCs) & B.Com (C.A), B.Com(e-Commerce) Programs for the student are admitted from the Academic Year 2021-22.
2. To Discuss and approve the Structure and Syllabi, Model Question Paper for Third Semester of B.Sc.(MPCs, MCCs.) & B.Com (C.A) Programs for the Academic Year 2021-22.
3. To Discuss and approve the Structure and Syllabi, Model Question Paper for Fifth Semester of B.Sc.(MPCs, MCCs.) & B.Com (C.A) Programs for the Academic Year 2021-22.
4. To recommend any changes in the syllabi for I, III, V Semesters of I, II, III year Degree B.Sc.(MPCs, MCCs, MSCs), B.Com.(C.A.) and B.Com(e-commerce).
5. To Introduce a New Programs for B.Sc (MSCs) and B.Com (e-commerce) from the Academic Year 2021-22.
6. To Introduce a Life Skill Course and Skill Development Course for all B.Sc and B.Com from the Academic Year 2021-22.
7. To recommend the teaching and evaluation methods to be followed under Autonomous status.
8. To recommend the panel of paper setters and examiners to the controller of the examinations of autonomous courses of AG & SG Siddhartha Degree College of Arts & Science College, Vuyyuru.
9. Any other matter

Resolutions.

- 1) It is Resolved and Recommended to adopt the structure and syllabi and Model Question Papers for first semester of B.Sc.(MPCs, MCCs, MSCs) & B.Com (C.A), B.Com(e-Commerce) Programs under CBCS(Choice Based Credit System) Approved by the Academic Council from the Academic Year 2021-22.
- 2) It is Resolved and Recommended to adopt the structure and syllabi and Model Question Papers for Third semester of B.Sc.(MPCs, MCCs) & B.Com (C.A), Programs under CBCS(Choice Based Credit System) Approved by the Academic Council from the Academic Year 2020-21
- 3) It is Resolved and Recommended to adopt the structure and syllabi and Model Question Papers for fifth semester of B.Sc.(MPCs, MCCs) & B.Com (C.A), Programs under CBCS(Choice Based Credit System) Approved by the Academic Council from the Academic Year 2020-21
- 4) It is Resolved and Recommend any changes in the syllabi for I, III, V Semesters of I, II, III year Degree B.Sc.(MPCs, MCCs, MSCs), B.Com.(C.A.) and B.Com(e-commerce).
 - It is Resolved and Recommend change Syllabi and Model Question paper as per new regulations in III Semester of II Year Degree B.Sc. (MPCs, MCCs) and B.Com(CA).
 - It is Resolved and recommend NO changes in the syllabi for III and V Semester of III Year B.Sc. (MPCs, MCCs) & B.Com.(CA).
- 5) It is Resolved to implements New Programs for B.Sc. (MSCs) and B.Com (e-commerce) from the Academic Year 2021-22.
- 6) It is Resolved to implements Life Skill Course and Skill Development Course for all B.Sc. and B.Com from the Academic Year 2021-22.
- 7) It is resolved to continue the teaching and evaluation methods to be followed under Autonomous status.
- 8) It is resolved to continue the panel of paper setters and examiners to the controller of the examinations of autonomous courses of AG & SG Siddhartha Degree College of Arts & Science College, Vuyyuru.
- 9) Any other matter

Teaching methods:

Besides the conventional methods of teaching, we use modern technology i.e. Using of LMS and LCD projector to display on power board etc..for better understanding of concepts.

Evaluation of a student is done by the following procedure:

There are two components in the Valuation and Assessment of a student – Internal Assessment (IA) Semester Examinations (SE). **For the Batch of Students Admitted from 2021-22.**

Internal Assessment (IA)

The maximum mark for IA is 25 and SE is 75 for theory; and for practical marks for IA 10 and 40 Marks for External Exam.

- Each IA written examination is of 1 hour 30 minutes duration for 20 marks. The tests will be conducted centrally. The average of two such IA is calculated for 20 marks.
- Other Innovative Components will be for 5 Marks. The innovative component is for 5 marks, conducted during the class hours by the staff member/ in charge of the subject, in the form of assignments/ quiz/ seminars /PPT/Online- assignments/Open Book/Viva Voce/ Group work/ Mini Project/ Exhibition, etc. The topic and time for submission/ presentation will be announced by the staff member/ in charge of the subject in advance. Each student should explain and defend his/her presentation.

- The semester examination will be of 3 hours with maximum 75 marks.
- There are no passing minimum marks for IA.

Internal Assessment (IA) For the Batch of Students Admitted from 2019-20.

- The maximum mark for IA is 30 and SE is 70 for theory; and for practical marks for IA 10 and 40 Marks for External Exam.
- Each IA written examination is of 1 hour 30 minutes duration for 20 marks. The tests will be conducted centrally. The average of two such IA is calculated for 20 marks.
- Other Innovative Components will be for 5 Marks. The innovative component is for 5 marks, conducted during the class hours by the staff member/ in charge of the subject, in the form of assignments/ quiz/ seminars /PPT/Online- assignments/Open Book/Viva Voce/ Group work/ Mini Project/ Exhibition, etc. The topic and time for submission/ presentation will be announced by the staff member/ in charge of the subject in advance. Each student should explain and defend his/her presentation.
- For attendance 5 Marks are allotted.
- The semester examination will be of 3 hours with maximum 70 marks.
- There are no passing minimum marks for IA.

Semester Examinations (SE)

- A student should register himself/herself to appear for the Semester Examinations by payment of the prescribed fee.
- The Semester Examinations will be in the form of a comprehensive examination covering the entire syllabus in each subject. It will be of 3 hours duration & Foundation course 2 hours irrespective of the number of credits allotted to it.
- If a candidate fails to obtain pass marks even after the due to less mark in the IA examination, the marks of the next examination will be converted to be out of 100.
- Even though the candidate is absent for two IA exams/obtain zero marks the external marks are considered (if he/she gets 40/100) and the result shall be declared as 'PASS'.
- The maximum marks for each Paper shall be 100.

Question paper guide lines for Practical Examinations at the end of Semesters I, III & V Two Practical Programs to be conducted out of 15 programs at the end of Semester I, III & V Practical Examination time 3Hrs and Maximum Marks 50 Scheme of valuation Semesters – I, III & V B.Sc.& B.Com.(C.A),

Computer Science Practical's - External (Time: 3 hrs.)

Total Marks: 40M

1. Programs writing (2):	20 marks,
2. Viva voice :	5 marks
3. Execution & Result :	15 marks

Total Marks : 40

Computer Science Practical's- Internal

Total Marks: 10 M

1. . Record : 10 marks

6.) Discussed and recommended for organizing Seminars, Guest lectures, Work-shops to upgrade the knowledge of students, for the approval of the Academic Council.

7) Discussed and empowered the HOD to suggest the panel of the paper setters and examiners to the controller of the examinations.

8). We implemented online certificate courses such as NPTL, APSSDC - PYTHON, R- Programming, Amazon Web services and JAVA -----etc. To fill the curriculum gaps from II year Degree on words

9). Suggestions

Chairman

AG & SG SIDDHARTHA COLLEGE OF ARTS AND SCIENCES - VUYYURU.
An Autonomous college within the jurisdiction of Krishna University A.P, India.
(With Effect from Academic Year 2021-22)

Computer Science Department Course Structure for B.Sc.(MPCs, MCCs & MSCs)

Sem. No	Name of the subject	Total Marks	Internal Exam	Sem. End Exam	Teaching Hours	Credits
I	Problem Solving in 'C'	100	25	75	4	4
	Problem Solving in 'C' Lab	50	10	40	2	1
III	Data Base Management System	100	30	70	4	3
	Data Base Management System Lab	50	10	40	2	2
V	Data Base Management System	100	30	70	4	3
	DataBase Management System Lab	50	10	40	2	2
	Software Engineering	100	30	70	4	3
	Software Engineering Lab	50	10	40	2	2

Course Structure for B.Com.(CA)&E-Commerce-Computers

Sem. No	Name of the Subject	Total Marks	Internal Exam	Sem. End Exam	Teaching Hours	Credits
I	Information Technology	100	25	75	5	4
	E-commerce & web Designing	100	25	75	4	3
	E-commerce & web Designing Lab	50	10	50	2	1
III	Office Automation Tools	100	30	70	4	3
	Office Automation Tools Lab	50	10	40	2	2
V	Object Oriented Programming in Java	100	30	70	4	3
	Object Oriented Programming in Java lab	50	10	40	2	2
	DataBase Management System	100	30	70	4	3
	DataBase Management System Lab	50	25	25	2	2
	Web Technologies	100	30	70	4	3
I(BA, B.Com,B. Sc.)	ICT (LIFE SKILL COURSE)	50	10	40	2	2

A.G & S.G.SIDDHARTHA DEGREE COLLEGE OF ARTS & SCIENCE

Vuyyuru-521165.NAAC reaccredited at 'A' level Autonomous -ISO 9001 – 2015 Certified

Title of the Paper: DATA BASE MANAGEMENT SYSTEMS

Semester: V

Course Code	CSC-501C	Course Delivery Method	Class Room / Blended Mode - Both
Credits	3	CIA Marks	30
No. of Lecture Hours / Week	4	Semester End Exam Marks	70
Total Number of Lecture Hours	60	Total Marks	100
Year of Introduction :2020-21	Year of Offering: 2021 - 22	Year of Revision: Nil	Percentage of Revision: 0%

Course Objective: Design & develop database for large volumes & varieties of data with optimized data processing techniques.

Course Outcomes:

CO ₁	Able to have knowledge about database, Traditional File System.
CO ₂	Be able to Design a database using Relation models and Data Modelling
CO ₃	Store, retrieve data in database using Integrity constraints and Normal Forms.
CO ₄	Be able to implement various SQL queries
CO ₅	Be able to implement various Procedural SQL queries and

Syllabus

Course Details

Unit	Learning Units	Lecture Hours
I	Introducing the database and DBMS, Why the database is important, Historical Roots: Files and File Systems, Problems with File System, Data Management, Database Systems. <i>Data Models:</i> The importance of Data models, Data Model Basic Building Blocks, The evaluation of Data Models, Degree of Data Abstraction.	12
II	Relational Database & Data Modelling Model: A logical view Data, Keys, Integrity Rules, Relational Set Operators, The D Dictionary and the system Catalog, Indexes, Codd's relational database rules .Entity Relationship Model: The ER Model <i>Advanced Data Modelling:</i> The Extended Entity Relationship Model, Entity clustering, Entity integrity.	12
III	Normalization and Database Design Data base Tables and Normalization, The need Normalization, The Normalization Process, High level Normal Forms, Normalization and database design, de normalization. Database Design: The Information System, The Systems Development Life Cycle, The Database Life Cycle, Centralized Vs Decentralized design.	14
IV	Structured Query Language Introduction to SQL: Data Definition Commands, Data Manipulation Commands, Select queries, Advanced Data Definition Commands, Advanced Select queries, Virtual Tables, SQL Join Operators, Sub queries and correlated queries, SQL Functions.	12
V	Procedural SQL: Introduction to PL/SQL: Triggers, Stored Procedures, PL/ SQL Stored Functions	10

Prescribed Text Book:

Peter Rob, Carlos Coronel, Database Systems Design, Implementation and Management, Seventh Edition, Thomson (2007).

Reference Books:

Elimasri / Navathe, Fundamentals of Database Systems, Fifth Edition, Pearson Addison Wesley 2.

Raman A Mata – Toledo/Panline K Cushman, Database Management Systems,

C.J.Date, Arkansan, S.Swamynathan, An Introduction to Database Systems, Eight editions,

“DatabaseSystemConcepts” by AbrahamSilberschatz, Henry Korth, and S.Sudarshan,

Atul Kahate, Introduction to Database Management Systems, Pearson Education (2006).

Student Activity: 1. Create your college database for placement purpose. 2. Create faculty database of your college with their academic performance scores

Course Focus: Fundamentals of knowledge base and relational database.

AG & SG SIDDHARTHA COLLEGE OF ARTS AND SCIENCES - VUYYURU.
An Autonomous college within the jurisdiction of Krishna University A.P, India.
(With Effect from Academic Year 2020-21)

COMPUTER SCIENCE	CSC-501C	2021-'22	B.Sc.(MPCs,MCCs)
-------------------------	-----------------	-----------------	-------------------------

SEMESTER – V

PAPER – V

Max. Marks 70

Model Paper: DATA BASE MANAGEMENT SYSTEMS

NO of Hours: 4

No Of Credits: 3

Pass Marks 28

Section-A

Answer any **FOUR** Questions. Each question carries **FIVE** Marks

4x5=20M

1. Explain the Components of Database System?
2. Explain Relational Data Model?
3. Write about Relational Set Operators?
4. Describe BCNF?
5. Write about Special Functions?
6. Explain Stored Procedures?

Section-B

Answer any **FIVE** Questions. Each question carries **TEN** Marks

5X10=50M

7. What is File? Explain the problems with File system
8. Explain the Degree of Data Abstraction
9. Explain E.F.CODDs' rules.
- 10.Explain Extended Entity Relationship Model
- 11.Explain the concept of Normal Forms
- 12.Explain about SDLC.
- 13.Explain DDL and DML commands.
- 14.Explain about triggers.

AG & SG SIDDHARTHA COLLEGE OF ARTS AND SCIENCES - VUYYURU.
An Autonomous college within the jurisdiction of Krishna University A.P, India.
(With Effect from Academic Year 2020-21)

COMPUTER SCIENCE	CSC-501C	2021-'22	B.Sc.(MPCs,MCCs)
------------------	----------	----------	------------------

SEMESTER – V PAPER – V Max. Marks 70 Pass Marks 28

Guidelines for paper setting '**DATA BASE MANAGEMENT SYSTEMS**'

Unit wise weight age of Marks

	Section-A (Short answer questions)	Section-B (essay questions)
Unit-1	2	2
Unit-2	1	2
Unit-3	1	2
Unit-4	1	1
Unit-5	1	1

- Each Short answer question carries 5 marks in Section –A
- Each Essay question carries 10 marks in Section –B
- The Question papers setters are requested to cover all the topics in the syllabus stipulated as per the weight age given by us

AG & SG SIDDHARTHA COLLEGE OF ARTS AND SCIENCES - VUYYURU.

An Autonomous college within the jurisdiction of Krishna University A.P, India.

(With Effect from Academic Year 2020-21)

COMPUTER SCIENCE	CSC-501P	2021-'22	B.Sc.(MPCS,MCCs)
-------------------------	-----------------	-----------------	-------------------------

SEMESTER – V

PAPER – V

Max. Marks 50

Lab List DATA BASE MANAGEMENT SYSTEMS

Pass Marks 25

No. of Hours per week: 2

External: 40

Internal: 10

Credits: 2

1. Creation of college database and establish relationships between tables
2. Explain various data type in Oracle.
3. Show the structure of the Emp table.
4. Show the structure of the DEPT table.
5. Explain the syntax of SELECT statement.
6. Create a query to display the name, job, hire date and employee number from emp table.
7. Create a query to display unique jobs from the EMP table.
8. Create a query to display the empno as EMP#, ename as EMPLOYEE and Hire date from emp.
9. Create a query to display all the data from the EMP table. Separate each column by a comma and name the column THE_OUTPUT.
10. Create a query to display the name and salary of employees earning more than 2850.
11. Create a query to display the name and salary for all employees whose salary is not in the range of 1500 and 2850.
12. Display the employee name, job and start date of employees hired between February 20 ,1981 and May 1, 1981. Order the query in ascending order of start date
13. Display the employee name and department number of all the employees in departments 10 and 30 in alphabetical order by name.
14. List the name and salary of employees who earn more than 1500 & are in department 10 or 30.
15. Display the name, salary and commissions and sort data in descending order of salary and commission.
16. Display the name and job title of all employees who do not have a manager.
17. Display the name, job and salary for all employees whose job is Clerk or Analyst and their salary is not equal to 1000, 3000 or 5000.
18. Display the names of all employees where the third letter of their name is an 'A'.
19. Display the names of all employees who have two 'L's in their name and are in department 30 or their manager is 7782.
20. Display the name, salary and commission for all employees whose commission amount is greater than their salary increased by 10%.
21. Explain all the character functions.
22. Explain all the number functions.
23. Explain all the Date functions.
24. Explain different types of JOIN.
25. Write a query to display the name, department number and department name for all employees.
26. Create a unique listing of all jobs that are in department 30. And include the location of department 30 in the output.
27. Write a query to display the employee name, department name and location of all employees who earn a commission.
28. Write a query to display the name, job department number and department name for all employees who work in 'DALLAS'.
29. Create a query to display the name and hire date of any employee hired after employee BLAKE.
30. . Display all employees' names and hire dates along with their manager's name and hire date for all employees who were hired before their managers.

31. Create your own users and give permissions to you and explain GRANT and REVOKE Commands.

A. Create MOVIE database using the following tables.

MOVIE: Movie no: primary key, varchar2
Movie name: NOT NULL, varchar2
Movie Type: varchar2
Star: Varchar2

CUSTOMER: Customer No: primary key, varchar2
Customer Name: NOT NULL, varchar2
Address: NOT NULL
Phone no: Number
INVOICE: Invoice no: Varchar2, primary key
Movie no: foreign key
Customer no: foreign key
Price: NOT NULL, Number

Queries:

1. List the movie names that starts with 'p'
2. List the number of the movies those price ranges from 15000 and 20000
3. List the customers who have phone numbers.
4. List the customers who have no phone numbers.
5. Display the following string
(a) A Customer "customer number" has bought the "movie number" "movie name" with "Price"
6. List the customers by calculating price as $(price * tax) / 100$ where $tax = 0.5$ and rename the column as 'tax'.
7. List the movies, which are owned by 2 customers.
8. List the customers, who bought 2 picture names.
9. List the customers, who are not the range of 15000 and 20000.

B. Create Student database using the following tables.

STUDENT: Sno : primary key, number
Sname : NOT NULL, varchar2
Address: Varchar2
COURSE: Sno : Foreign key.
Course Name : varchar2

Queries:

1. Alter table by adding a column fees in table COURSE.
2. Alter table by modifying the address to VARCHAR2(20)
3. Create a view on which the students who joined in one course only.

PL/SQL.

1. Write A Pl/Sql Program To Swap Two Numbers Without Using Third Variable.
2. Write A Pl/Sql Program To Generate Multiplication Tables For Numbers 2,4 And 6
3. Write A Pl/Sql Program To Display Sum Of Even Numbers And Sum Of Odd Numbers In The Given Range.
4. Write A Pl/Sql Program To Check The Given Number Is Pollinndrome Or Not.
5. Write A Pl/Sql Program To Display Top 10 Rows In EMP Table Based On Their Job And Salary.
6. Write a Procedure Update the Salary of Employee, Who is Not Getting Commission by 10%.

Reference Books:

1. Oracle Pl/Sql by Example. Benjamin Rosenzweig, Elena Silvestrova, Pearsoneducation 3rd Edition
2. Sql& Pl/Sql For Oracle 10g, Black Book, Dr.P.S. Deshpande

A.G & S.G.SIDDHARTHA DEGREE COLLEGE OF ARTS & SCIENCE

Vuyyuru-521165. NAAC recredited at 'A' level Autonomous *-ISO 9001 – 2015 Certified*

Title of the Paper: SOFTWARE ENGINEERING

Semester: V

Course Code	CSC-502C	Course Delivery Method	Class Room / Blended Mode - Both
Credits	3	CIA Marks	30
No. of Lecture Hours / Week	4	Semester End Exam Marks	70
Total Number of Lecture Hours	60	Total Marks	100
Year of Introduction :2018-19	Year of Offering: 2021 - 22	Year of Revision: 2020	Percentage of Revision: 10%

Course Objective: The Objective of the course is to assist the student in understanding the basic theory of software engineering, and to apply these basic theoretical principles to a group software development project.

Course Outcomes:

CO ₁	1. Understand the concepts of Software Engineering and Process
CO ₂	2. Ability to use perfect models according to the requirements of the software projects.
CO ₃	3. Ability to analyze software requirements with existing tools.
CO ₄	4. Able to use different class diagrams, user interface designs, chart diagrams.
CO ₅	5. Able to differentiate different testing methodologies and Design Engineering

Syllabus

Course Details

Unit	Learning Units	Lecture Hours
I	Introduction to Software Engineering & Process : The Evolving Role of Software – Software - The Changing Nature of Software, Software Myths, Legacy Software. <i>Process:</i> Software Engineering-A Layered Technology - A Process Framework - The Capability Maturity Model Integration (CMMI) - Process Patterns, Process Assessments - Personal Software Process (PSP), Team Software Process (TSP).	12
II	Process Model: The Increment Model, The RAD Model - Evolutionary Process Models: Prototyping, The Spiral Model, And The Concurrent Development Model.	12
III	Requirements Engineering: Requirements Engineering Tasks - Initiating The Requirements Engineering Process - Eliciting Requirements: Collaborative Requirements Gathering, Quality Function Deployment, User Scenarios, and Elicitation Work Products - Negotiating Requirements - Validating Requirements.	14
IV	Design Engineering Design Process And Design Quality - Design Concepts - The Design Model: Data Design Elements, Architectural Design Elements, Interface Design Elements, Component-Level Design Elements, and Deployment - Level Design Elements.	10
V	Software Quality: Quality and Quality Concepts, Software Quality Assurance (SQA), Software Reviews, Formal Technical Reviews, Formal Approaches to SQA and SSQA, Software Reliability, The ISO 9000 Quality Standards, The SQA Plan.	12

Prescribed Text Book:

1. Software Engineering – A Practitioner’s Approach, Sixth Edition - Roger S Pressman, TATA McGrawHill: Chapters: 1,2,3,7,8 and 9)

Reference Books:

1. Software Engineering Principles and Practice by Deepak Jain Oxford University Press
2. Sommerville, “Software Engineering”, Eighth Edition, Pearson Education, 2007

- Student Activity:** Visit any financial organization nearby and prepare requirement analysis report
 2. Visit any industrial organization and prepare risk chart.

Course Focus: To provide Systematic, cost-effective and quantifiable processes, techniques and tools to design, construct and deploy software systems

AG & SG SIDDHARTHA COLLEGE OF ARTS AND SCIENCES - VUYYURU.
An Autonomous college within the jurisdiction of Krishna University A.P, India.
(With Effect from Academic Year 2020-21)

COMPUTER SCIENCE	CSC-502C	2021-'22	B.Sc.(MPCs,MCCs)
-------------------------	-----------------	-----------------	-------------------------

SEMESTER – V

PAPER – VI

Max. Marks 70

Model Paper

SOFTWARE ENGINEERING

NO of Hours: 4

No Of Credits: 3

Pass Marks 28

Section – A

Answer any **FOUR** Questions. Each question carries **FIVE** Marks

4x5=20M

1. Write about Software Layered Technology?
2. Explain about Process Framework?
3. Explain about RAD Model?
4. Explain Validating Requirements
5. Explain about Modularity?
6. Write about Software Reliability?

Section – B

Answer any **FIVE** Questions. Each question carries **TEN** Marks

5X10=50M

7. Explain about CMMI?
8. Explain about Software Myths?
9. Explain about Incremental Model?
10. Explain about Spiral Model
11. Explain about Requirements Engineering Tasks?
12. Write about design concepts in design engineering?
13. Explain about Quality and Quality Concepts?
14. Write about SSQA?

AG & SG SIDDHARTHA COLLEGE OF ARTS AND SCIENCES - VUYYURU.
An Autonomous college within the jurisdiction of Krishna University A.P, India.
(With Effect from Academic Year 2020-21)

COMPUTER SCIENCE	CSC-502C	2021-'22	B.Sc.(MPCs,MCCs)
------------------	----------	----------	------------------

SEMESTER – V PAPER – VI Max. Marks 70 Pass Marks 28

Guidelines for paper setting '**SOFTWARE ENGINEERING**'

Unit wise weight age of Marks

	Section-A (Short answer questions)	Section-B (essay questions)
Unit-1	2	2
Unit-2	1	2
Unit-3	1	2
Unit-4	1	1
Unit-5	1	1

- Each Short answer question carries 5 marks in Section –A
- Each Essay question carries 10 marks in Section –B
- The Question papers setters are requested to cover all the topics in the syllabus stipulated as per the weight age given by us

AG & SG SIDDHARTHA COLLEGE OF ARTS AND SCIENCES - VUYYURU.
An Autonomous college within the jurisdiction of Krishna University A.P, India.
(With Effect from Academic Year 2020-21)

COMPUTER SCIENCE	CSC-502C	2021-'22	B.Sc.(MPCS,MCCs)
-------------------------	-----------------	-----------------	-------------------------

SEMESTER – V

PAPER – VI

Max. Marks 50

Lab List

SOFTWARE ENGINEERING

Pass Marks 25

No. of Hours per week: 2

External: 40 Internal: 10

Credits: 2

A. ATM

- | | |
|--------------------------------------|--|
| 1. Objective of an ATM System. | 5. Activity Diagram of an ATM System |
| 2. Use-case Diagram of an ATM System | 6. State Diagram of an ATM System |
| 3. Class Diagram of an ATM System | 7. Deployment Diagram of an ATM System |
| 4. Sequence Diagram of an ATM System | |

B. Library management System

- | | |
|---|---|
| 1. Objective of Library management System. | 5. Activity Diagram of Library management System |
| 2. Use-case Diagram of Library management | 6. State Diagram of Library management |
| 3. Class Diagram of Library management System | 7. Deployment Diagram of Library management System. |
| 4. Sequence Diagram of Library management | |

C. Barcode Reader

- | | |
|---------------------------------------|---|
| 1. Objective of Barcode Reader | 5. Activity Diagram of Barcode Reader |
| 2. Use-case Diagram of Barcode Reader | 6. State Diagram of Barcode Reader |
| 3. Class Diagram of Barcode Reader | 7. Deployment Diagram of Barcode Reader |
| 4. Sequence Diagram of Barcode Reader | |

D. Safe Home System

- | | |
|---|---|
| 1. Objective of Safe Home System. | 5. Activity Diagram of Safe Home System |
| 2. Use-case Diagram of Safe Home System | 6. State Diagram of Safe Home System |
| 3. Class Diagram of Safe Home System | 7. Deployment Diagram of Safe Home System |
| 4. Sequence Diagram of Safe Home System | |

E. Online Book Store System

- | | |
|---|---|
| 1. Objective of Online Book Store System | 5. Activity Diagram of Online Book Store System |
| 2. Use-case Diagram of Online Book Store System | 6. State Diagram of Online Book Store System |
| 3. Class Diagram of Online Book Store System | 7. Deployment Diagram of Online Book Store System |
| 4. Sequence Diagram of Online Book Store | |

A.G & S.G.SIDDHARTHA DEGREE COLLEGE OF ARTS & SCIENCE

Vuyyuru-521165. NAAC recredited at 'A' level Autonomous *-ISO 9001 – 2015 Certified*

Title of the Paper: OBJECT ORIENTED PROGRAMMING USING JAVA

Semester: V

Course Code	CCSC-505C	Course Delivery Method	Class Room / Blended Mode - Both
Credits	3	CIA Marks	30
No. of Lecture Hours / Week	4	Semester End Exam Marks	70
Total Number of Lecture Hours	60	Total Marks	100
Year of Introduction :2020-21	Year of Offering: 2021 - 22	Year of Revision: Nil	Percentage of Revision: 0%

Course Objective: This Course will enable students to understand the basic concepts of object oriented programming and difference between procedure-oriented programming; get a clear understanding of basics of java programming

Course Outcomes:

CO ₁	Able to Understand the concept and underlying principles of Object-Oriented Programming.
CO ₂	Able to Understand the Basic concepts of Data types & Operators
CO ₃	Able to Implement Decision & Looping Statements
CO ₄	Able to Implement Object Oriented Programming Concepts like class, constructor, overloading in java.
CO ₅	Able to Understand the concept of Inheritance and Exceptions Object-Oriented Programming.

Syllabus

Unit	Learning Units	Lecture Hours
I	Fundamentals of Object – Oriented Programming: Introduction, Object Oriented paradigm, Basic Concepts of OOP, Benefits of OOP, Applications of OOP, Java features:	10
II	Overview of Java Language: Introduction, Simple Java program structure, Java tokens, Java Statements, Implementing a Java Program, Java Virtual Machine, Command line arguments. Constants, Variables & Data Types: Introduction, Constants, Variables, Data Types, Declaration of Variables, Giving Value to Variables, Scope of variables, Type casting, Getting Value of Variables, Operators.	14
III	Decision Making & Branching: Introduction, Decision making with if statement, Simple if statement, if-else statement, Nesting of if-else statements, the else if ladder, the switch statement, the conditional operator. Looping: Introduction, while statement, do-while statement, for statement, Jumps in loops.	12
IV	Classes, Objects & Methods: Introduction, defining a class, adding variables, adding methods, creating objects, Accessing class members, Constructors, Method overloading, Method Overriding, Static members, Nesting of methods;	12
V	Inheritance: Extending a Class, Overriding Methods, Final Variables and Methods, Final Classes, Abstract Methods and Classes; Arrays, Strings And Vectors: Arrays, One-dimensional arrays, Creating an array, Two – dimensional arrays, Strings, Vectors, Wrapper classes; Interfaces: Multiple Inheritance: Introduction, Defining interfaces, Extending interfaces, Implementing interfaces, Assessing interface variables;	12

Prescribed Text Book:

1. E. Balaguruswamy, Programming with JAVA, A primer, 3e, TATA McGraw-Hill Company.

Reference Books

1. Programming In Java By Sachin Malhotra And Saurabh Choudhary From Oxford University Press
2. Object Oriented Programming Through Java by P. Radha Krishna, Universities Press
3. John R. Hubbard, Programming with Java, Second Edition, Schaum’s outline Series,
4. Deitel&Deitel. Java TM: How to Program, PHI (2007)
5. Java Programming: From Problem Analysis to Program Design- D.S Mallik

Course Focus: OOP focus on the objects that developers want to manipulate rather than the logic required to manipulate them.

(With Effect from Academic Year 2020-21)

COMPUTER SCIENCE

CCSC-505C

2021-22

B. Com (CA)

SEMESTER – V PAPER – V

Max. Marks 70

Pass Marks 28

Syllabus: OBJECT ORIENTED PROGRAMMING USING JAVA

Total Hrs: 60

NO. Of. Hours: 4

Credits: 3

Section- A

Answer **FOUR** Questions. Each Question carries FIVE Marks.

4*5=20M

1. What are the Applications of OOP?
2. What is a variable? Explain its rules?
3. Explain different data types in java?
4. Write about switch statement?
5. Explain about Constructors?
6. Differences between arrays and vectors?

Section- B

Answer **FIVE** the Questions. Each Question carries TEN Marks

5*10=50M

7. Explain the Concepts of Object Oriented Programming?
8. Explain java Features?
9. Explain the structure of java program?
10. Explain different types of Operators in Java with Examples?
11. Explain about Decision Making Statements with examples?
12. Explain Looping statements with example?
13. Explain Method overloading with an example program?
14. Explain about inheritance?

(With Effect from Academic Year 2020-21)

COMPUTER SCIENCE

CCSC-505C

2021-22

B. Com (CA)

SEMESTER – V PAPER – V

Max. Marks 70

Pass Marks 28

Syllabus:

OBJECT ORIENTED PROGRAMMING USING JAVA

Total Hrs: 60

NO. Of. Hours: 4

Credits: 3

Unit wise weight age of Marks

	Section-A (Short answer questions)	Section-B (essay questions)
Unit-1	1	2
Unit-2	2	2
Unit-3	1	2
Unit-4	1	1
Unit-5	1	1

- Each Short answer question carries 5 marks in Section –A
- Each Essay question carries 10 marks in Section –B
- The Question papers setters are requested to cover all the topics in the syllabus stipulated as per the weight age given by us

AG & SG SIDDHARTHA COLLEGE OF ARTS AND SCIENCES - VUYYURU.

An Autonomous college within the jurisdiction of Krishna University A.P, India.

(With Effect from Academic Year 2020-21)

SEMESTER – V

PAPER – V

Lab List: OBJECT ORIENTED PROGRAMMING USING JAVA Pass Marks 25**No. of Hours per week: 2****External: 40****Internal: 10****Credits: 2**

1. Write a program to perform various String Operations
2. Write a program to print the given number is Armstrong or not?
3. Prompt for the cost and selling price of an article and display the profit (or) loss
4. Write a program to print the numbers given by command line arguments
5. Write a program on class and object in java
6. Illustrate the method overriding in JAVA
7. Write a program to find the Simple Interest using Multilevel Inheritance
8. Write a program to display matrix multiplication.
9. Write a program on interface in java
10. Write a program on inheritance

Title of the Paper: DATA BASE MANAGEMENT SYSTEMS**Semester: V**

Course Code	CCSC-506C	Course Delivery Method	Class Room / Blended Mode - Both
Credits	3	CIA Marks	30
No. of Lecture Hours / Week	4	Semester End Exam Marks	70
Total Number of Lecture Hours	60	Total Marks	100
Year of Introduction :2020-21	Year of Offering: 2021 - 22	Year of Revision: Nil	Percentage of Revision: 0%

Course Objective: Design & develop database for large volumes & varieties of data with optimized data processing techniques.

Course Outcomes:

CO ₁	Able to have knowledge about database, Traditional File System.
CO ₂	Be able to Design a database using Relation models and Data Modelling
CO ₃	Store, retrieve data in database using Integrity constraints and Normal Forms.
CO ₄	Be able to implement various SQL queries
CO ₅	Be able to implement various Procedural SQL queries and

Syllabus**Course Details**

Unit	Learning Units	Lecture Hours
I	Database Systems Introduction <i>Database Systems:</i> Introducing the database and DBMS, Why the database is important, <i>Historical Roots:</i> Files and File Systems, Problems with File System, Data Management, Database Systems. <i>Data Models:</i> The importance of Data models, Data Model Basic Building Blocks, The evaluation of Data Models.	12
II	Relational Database & Data Modelling <i>The Relational Database Model:</i> A logical view of Data, Keys, Integrity Rules, Relational Set Operators, Indexes, Codd's relational database rules. <i>Entity Relationship Model:</i> The ER Model <i>Advanced Data Modelling:</i> The Extended Entity Relationship Model, Entity clustering.	12
III	Normalization and Database Design <i>Normalization of database tables:</i> Database Tables and Normalization, The need for Normalization, The Normalization Process, High level Normal Forms, Normalization and database design, de normalization.	14
IV	Structured Query Language <i>Introduction to SQL:</i> Data Definition Commands, Data Manipulation Commands, Select queries, Advanced Data Definition Commands, Advanced Select queries, Virtual Tables, SQL Join Operators,	12
V	Procedural SQL <i>Introduction to PL/SQL :</i> Triggers, Stored Procedures, PL/ SQL Stored Functions	10

Prescribed Text Book:

1. Peter Rob, Carlos Coronel, **Database Systems Design, Implementation and Management, Seventh Edition, Thomson (2007).**

Reference Books:

2. Elmasri / Navathe, Fundamentals of Database Systems, Fifth Edition, Pearson Addison Wesley
3. C.J.Date, A.Kannan, S.Swamynathan, An Introduction to Database Systems, Eight editions, Pearson Education (2006).

Course Focus: Fundamentals of knowledge base and relational database.

(With Effect from Academic Year 2020-21)

COMPUTER SCIENCE

CCSC 506C

2021-'22

B.Com.(C.A.)

SEMESTER – V

PAPER – VI

Max. Marks 70

Model Paper

DATA BASE MANAGEMENT SYSTEMS

NO of Hours: 5

No Of Credits: 3

Pass Marks 28

Section-A

Answer any **FOUR** Questions. Each question carries **FIVE** Marks

4x5=20M

1. Explain the Components of Database System?
2. Explain Entity Relationship Model?
3. Write about Relational Set Operators?
4. Describe BCNF?
5. Write about Special Functions?
6. Explain Stored Procedures?

Section-B

Answer any **FIVE** Questions. Each question carries **TEN** Marks

5X10=50M

7. What is File? Explain the problems with File system?
8. Explain any three different Data Models?
9. Explain E.F. CODDs' rules?
10. Explain Extended Entity Relationship Model?
11. Explain the concept of Normal Forms?
12. Explain different join operators?
13. Explain DDL and DML commands?
14. Explain about triggers?

(With Effect from Academic Year 2020-21)

COMPUTER SCIENCE

CCSC 506C

2021-'22

B.Com.(C.A.)

SEMESTER – V

PAPER – VI Max. Marks 70

Pass Marks 28

Guidelines for paper setting '**DATA BASE MANAGEMENT SYSTEMS**'

Unit wise weightage of Marks

	Section-A (Short answer questions)	Section-B (essay questions)
Unit-1	2	2
Unit-2	1	2
Unit-3	1	1
Unit-4	1	2
Unit-5	1	1

- Each Short answer question carries 5 marks in Section –A
- Each Essay question carries 10 marks in Section –B
- The Question papers setters are requested to cover all the topics in the syllabus stipulated as per the weightage given by us

AG & SG SIDDHARTHA COLLEGE OF ARTS AND SCIENCES - VUYYURU.

An Autonomous college within the jurisdiction of Krishna University A.P, India.

(With Effect from Academic Year 2020-21)

SEMESTER – V

PAPER – VI

Max. Marks 50

Lab List DATA BASE MANAGEMENT SYSTEMS

Pass Marks 25

No. of Hours per week: 2

External: 40

Internal: 10

Credits: 2

1. Creation of college database and establish relationships between tables
2. Explain various data type in Oracle.
3. Show the structure of the Emp table.
4. Show the structure of the DEPT table.
5. Explain the syntax of SELECT statement.
6. Create a query to display the name, job, hiredate and employee number from emp table.
7. Create a query to display unique jobs from the emp table.
8. Create a query to display the empno as EMP#, ename as EMPLOYEE and Hire_date from emp.
9. Create a query to display all the data from the EMP table. Separate each column by a comma and name the column THE_OUTPUT.
10. Create a query to display the name and salary of employees earning more than 2850.
11. Create a query to display the name and salary for all employees whose salary is not in the range of 1500 and 2850.
12. Display the employee name, job and start date of employees hired between February 20 ,1981 and May 1, 1981. Order the query in ascending order of start date
13. Display the employee name and department number of all the employees in departments 10 and 30 in alphabetical order by name.
14. List the name and salary of employees who earn more than 1500 & are in department 10 or 30.
15. Display the name, salary and commissions and sort data in descending order of salary and commission.
16. Display the name and job title of all employees who do not have a manager.
17. Display the name, job and salary for all employees whose job is Clerk or Analyst and their salary is not equal to 1000, 3000 or 5000.
18. Display the names of all employees where the third letter of their name is an 'A'.
19. Display the names of all employees who have two 'L's in their name and are in department 30 or their manager is 7782.
20. Display the name , salary and commission for all employees whose commission amount is grater than their salary increased by 10%.
21. Explain all the character functions.
22. Explain all the number functions.
23. Explain all the Date functions.

Create Student database using the following tables.

STUDENT: Sno : primary key, numberSname : NOT NULL, varchar2 Address: Varchar2

COURSE:Sno : Foreign key.Course Name : varchar2

Queries:

1. Alter table by adding a column fees in table COURSE.
2. Alter table by modifying the address to VARCHAR2(20)
3. Create a view on which the students who joined in one course only.

PL/SQL.

1. Write A Pl/Sql Program To Swap Two Numbers Without Using Third Variable.
2. Write A Pl/Sql Program To Generate Multiplication Tables For Numbers 2,4 And 6

3. Write A Pl/Sql Program To Display Sum Of Even Numbers And Sum Of Odd Numbers In The Given Range.
4. Write A Pl/Sql Program To Check The Given Number Is Pollinndrome Or Not.
5. Write A Pl/Sql Program To Display Top 10 Rows In Emp Table Based On Their Job And Salary.

Reference Books:

1. Oracle Pl/Sql By Example. Benjamin Rosenzweig, Elena Silvestrova, Pearsoneducation 3rd Edition
2. Sql& Pl/Sql For Oracle 10g, Black Book, Dr.P.S. Deshpande

Title of the Paper: WEB TECHNOLOGIES**Semester: V**

Course Code	CCSC-507C	Course Delivery Method	Class Room / Blended Mode - Both
Credits	3	CIA Marks	30
No. of Lecture Hours / Week	5	Semester End Exam Marks	70
Total Number of Lecture Hours	60	Total Marks	100
Year of Introduction :2020-21	Year of Offering: 2021 - 22	Year of Revision: ----	Percentage of Revision: 0%

Course Objective: The student will be able to analyze a web page and identify its elements and attributes.

Course Outcomes:

CO ₁	Understand the basic structure of a HTML design and develop a website using different text formatting tags, images, links, lists and tables.
CO ₂	Understand to style a webpage using CSS and Basic Concepts Of Java Scripts
CO ₃	Understand to style a webpage Using Objects in Java Script and DHTML
CO ₄	Understand the Basic Concepts of XML and Defining Data for Web Applications.
CO ₅	Understand the Concepts of JSP

Syllabus**Course Details**

Unit	Learning Units	Lecture Hours
I	Introduction to XHTML: Introduction to HTML, Basic html, Document body text, Hyperlinks, Lists, Tables, Images, Frames, Forms and XHTML.	13
II	CSS: Cascading Style Sheets: Introduction, Defining your own styles, properties and values in styles, Formatting blocks of information, Layers. Java Script: java Script, the basics, Variables, String Manipulations, Mathematical functions, Statements, Operators.	12
III	Objects in Java Script & Dynamic HTML with Java Script <i>Objects in Java Script:</i> Data and objects in java script, Regular expressions, Exception Handling, built in objects, Events. <i>Dynamic HTML with Java Script:</i> Data validation, Rollover buttons, Moving images.	13
IV	XML Defining Data for Web Applications <i>XML:</i> Introduction to XML, Basic XML, document type definition, XML Schema, Document object model, Using XML parser.	12
V	JSP: JSP Lifecycle, Basic Syntax, EL (Expression Language), EL Syntax, Using EL Variables	10

Prescribed Books:

1. Chris Bates, Web Programming Building Internet Application, Second Edition, Wiley
2. Head First Servlets and JSP 2nd Edition, Bryan Basham, Kathy Sierra
3. Uttam Kumar Roy, Web Technologies from Oxford University Press

Course Focus: WWW as a platform for interactive applications, content publishing and social services

**An Autonomous college within the jurisdiction of Krishna University A.P, India.
(With Effect from Academic Year 2018-'19)**

COMPUTER SCIENCE

CCSC-507C

2021-'22

B.Sc.(MPCs)

SEMESTER – V

PAPER – VII

Max. Marks 70

Model Paper

WEB TECHNOLOGIES

No of Credits: 3

Pass Marks 28

Section-A

Answer **FOUR** Questions. Each Question carries **FIVE** Marks.

5 X 4=20M

1. Write about structure of HTML Document with an example?
2. Explain about lists in HTML?
3. Write about java script statements?
4. Write about Rollover buttons?
5. Describe XML Elements?
6. Write the syntax of EL and EL variables?

Section-B

Answer **FIVE** Questions. Each Question carries **TEN** Marks.

5 X 10=50M

7. Explain about hyper links? Write about how to link another pages
8. What is Form? Explain about forms with examples
9. What is CSS? How to design Cascading style sheet
10. Explain about Mathematical Functions
11. Explain about Regular Expressions
12. Write about Data validations in DHTML
13. Explain about Document Object Model
14. Explain about JSP Lifecycle with neat diagram

**An Autonomous college within the jurisdiction of Krishna University A.P, India.
(With Effect from Academic Year 2020-21)**

COMPUTER SCIENCE	CCSC-507C	2021-'22	B.COM(CA)
------------------	-----------	----------	-----------

SEMESTER – VI

PAPER – VII

Max. Marks 70

Pass Marks 28

Guidelines for paper setting '**WEB TECHNOLOGIES**'

Unit wise weight age of Marks

	Section-A (Short answer questions)	Section-B (essay questions)
Unit-1	2	2
Unit-2	1	2
Unit-3	1	2
Unit-4	1	1
Unit-5	1	1

- Each Short answer question carries 5 marks in Section –A
- Each Essay question carries 10 marks in Section –B
- The Question papers setters are requested to cover all the topics in the syllabus stipulated as per the weight age given by us

Title of the Paper: DATA BASE MANAGEMENT SYSTEMS

Semester: III

Course Code	CSC-301C	Course Delivery Method	Class Room / Blended Mode – Both
Credits	3	CIA Marks	30
No. of Lecture Hours / Week	4	Semester End Exam Marks	70
Total Number of Lecture Hours	60	Total Marks	100
Year of Introduction :2020-21	Year of Offering: 2021 - 22	Year of Revision: ----	Percentage of Revision: 0%

Course Objective: The objective of the course is to introduce the design and development of databases with special emphasis on relational databases.

Course Outcomes:

CO ₁	Able to have knowledge about database, Traditional File System.
CO ₂	Be able to Design a database using Relation models and Data Modelling
CO ₃	Store, retrieve data in database using Integrity constraints and Normal Forms.
CO ₄	Be able to implement various SQL queries
CO ₅	Be able to implement various Procedural SQL queries and

Course Details

Unit	Learning Units	Lecture Hours
I	Overview of Database Management System: Introduction to data, information, database, database management systems, file-based system, Drawbacks of file-Based System, database approach, Classification of Database Management Systems, advantages of database approach, Various Data Models, Components of Database Management System, three schema architecture of data base, costs and risks of database approach.	12
II	Entity-Relationship Model: Introduction, the building blocks of an entity relationship diagram, classification of entity sets, attribute classification, relationship degree, relationship classification, reducing ER diagram to tables, enhanced entity-relationship model (EER model), generalization and specialization, IS A relationship and attribute inheritance, multiple inheritance, constraints on specialization and generalization, advantages of ER modelling.	12
III	Relational Model: Introduction, CODD Rules, relational data model, concept of key, relational integrity, relational algebra, relational algebra operations, advantages of relational algebra, limitations of relational algebra, relational calculus, tuple relational calculus, domain relational Calculus (DRC), Functional dependencies and normal forms upto 3rd normal form.	12
IV	Structured Query Language: Introduction, History of SQL Standard, Commands in SQL, Data Types in SQL, Data Definition Language, Selection Operation, Projection Operation, Aggregate functions, Data Manipulation Language, Table Modification Commands, Join Operation, Set Operations, View, Sub Query.	12
V	PL/SQL: Introduction, Shortcomings of SQL, Structure of PL/SQL, PL/SQL Language Elements, Data Types, Operators Precedence, Control Structure, Steps to Create a PL/SQL, Program, Iterative Control, Procedure, Function, Database Triggers, Types of Triggers.	12

Prescribed Text Book:

1. Database System Concepts by Abraham Silberschatz, Henry Korth, and S. Sudarshan, McGrawhill
2. Database Management Systems by Raghu Ramakrishnan, McGrawhill
3. Principles of Database Systems by J. D. Ullman
4. Fundamentals of Database Systems by R. Elmasri and S. Navathe
5. SQL: The Ultimate Beginners Guide by Steve Tale.

Course Focus: Fundamentals of knowledge base and relational database.

AG & SG SIDDHARTHA COLLEGE OF ARTS AND SCIENCES - VUYYURU.
An Autonomous college within the jurisdiction of Krishna University A.P, India.
(With Effect from Academic Year 2021-22)

COMPUTER SCIENCE	CSC-301C	2021-'22	B.Sc.(MPCs,MCCs)
-------------------------	-----------------	-----------------	-------------------------

SEMESTER – III

PAPER – III

Max. Marks 70

Model Paper: DATA BASE MANAGEMENT SYSTEMS

NO of Hours: 4

No Of Credits: 3

Pass Marks 28

Section-A

Answer any FOUR Questions. Each question carries FIVE Marks

4x5=20M

1. Explain the Components of Database System?
2. Explain about advantages of database approach?
3. Explain building blocks of an entity relationship diagram?
4. Describe BCNF?
5. Write about Special Functions?
6. Explain Stored Procedures?

Section-B

Answer any FIVE Questions. Each question carries TEN Marks

5X10=50M

7. What is File? Explain the problems with File system
8. Explain the Degree of Data Abstraction.
9. Explain E.F.CODDs' rules.
10. Explain Extended Entity Relationship Model.
11. Explain the concept of Normal Forms.
12. Explain about SDLC.
13. Explain DDL and DML commands.
14. Explain about triggers.

AG & SG SIDDHARTHA COLLEGE OF ARTS AND SCIENCES - VUYYURU.

**An Autonomous college within the jurisdiction of Krishna University A.P, India.
(With Effect from Academic Year 2021-22)**

COMPUTER SCIENCE	CSC-301C	2021-'22	B.Sc.(MPCs,MCCs)
------------------	----------	----------	------------------

SEMESTER – III PAPER –III Max. Marks 70 Pass Marks 28

Guidelines for paper setting '**DATA BASE MANAGEMENT SYSTEMS**'

Unit wise weight age of Marks

	Section-A (Short answer questions)	Section-B (essay questions)
Unit-1	2	2
Unit-2	1	2
Unit-3	1	2
Unit-4	1	1
Unit-5	1	1

- Each Short answer question carries 5 marks in Section –A
- Each Essay question carries 10 marks in Section –B
- The Question papers setters are requested to cover all the topics in the syllabus stipulated as per the weight age given by us

AG & SG SIDDHARTHA COLLEGE OF ARTS AND SCIENCES - VUYYURU.

An Autonomous college within the jurisdiction of Krishna University A.P, India.

(With Effect from Academic Year 2021-22)

COMPUTER SCIENCE	CSC-301P	2021-'22	B.Sc.(MPCS,MCCs)
-------------------------	-----------------	-----------------	-------------------------

SEMESTER – III

PAPER – III

Max. Marks 50

Lab List DATA BASE MANAGEMENT SYSTEMS

Pass Marks 25

No. of Hours per week: 2

External: 40

Internal: 10

Credits: 2

1. Draw ER diagram for hospital administration
 2. Creation of college database and establish relationships between tables
 3. Relational database schema of a company is given in the following figure.
Relational Database Schema - COMPANY
- Questions to be performed on above schema**
1. Create above tables with relevant *Primary Key, Foreign Key and other constraints*
 2. Populate the tables with data
 3. Display all the details of all employees working in the company.
 4. Display *ssn, lname, fname, address* of employees who work in department no 7.
 5. Retrieve the *Birthdate and Address* of the employee whose name is 'Franklin T. Wong'
 6. Retrieve the name and salary of every employee
 7. Retrieve all distinct salary values
 8. Retrieve all employee names whose address is in 'Bellaire'
 9. Retrieve all employees who were born during the 1950s
 10. Retrieve all employees in department 5 whose salary is between 50,000 and 60,000(inclusive)
 11. Retrieve the names of all employees who do not have supervisors
 12. Retrieve SSN and department name for all employees
 13. Retrieve the name and address of all employees who work for the 'Research' department
 14. For every project located in 'Stafford', list the project number, the controlling department number, and the department manager's last name, address, and birth date.
 15. For each employee, retrieve the employee's name, and the name of his or her immediate supervisor.
 16. Retrieve all combinations of Employee Name and Department Name
 17. Make a list of all project numbers for projects that involve an employee whose last name is 'Narayan' either as a worker or as a manager of the department that controls the project.
 18. Increase the salary of all employees working on the 'ProductX' project by 15%. Retrieve employee name and increased salary of these employees.
 19. Retrieve a list of employees and the project name each works in, ordered by the employee's department, and within each department ordered alphabetically by employee first name.

20. Select the names of employees whose salary does not match with salary of any employee in department 10.
21. Retrieve the employee numbers of all employees who work on project located in Bellaire, Houston, or Stafford.
22. Find the sum of the salaries of all employees, the maximum salary, the minimum salary, and the average salary. Display with proper headings.
23. Find the sum of the salaries and number of employees of all employees of the 'Marketing' department, as well as the maximum salary, the minimum salary, and the average salary in this department.
24. Select the names of employees whose salary is greater than the average salary of all employees in department 10.
25. Delete all dependents of employee whose *ssn is '123456789'*.
26. Perform a query using alter command to drop/add field and a constraint in Employee table.

A.G & S.G.SIDDHARTHA DEGREE COLLEGE OF ARTS & SCIENCE

Vuyyuru-521165. NAAC reaccredited at 'A' level Autonomous *-ISO 9001 – 2015 Certified*

Title of the Paper: PROGRAMMING IN C

Semester: III

Course Code	CCSC 301C	Course Delivery Method	Class Room / Blended Mode - Both
Credits	3	CIA Marks	30
No. of Lecture Hours / Week	4	Semester End Exam Marks	70
Total Number of Lecture Hours	60	Total Marks	100
Year of Introduction :2020-21	Year of Offering: 2021 - 22	Year of Revision: ----	Percentage of Revision: 0% (shuffled from 4 th to 3 rd sem)

Course Objective: The Course is designed to provide complete knowledge of C language. Students will be able to develop logics which help them to create programs in C.

Course Outcomes:

CO ₁	1. Analyze a given problem and develop an algorithm to solve the problem
CO ₂	2. Understand the C tokens and control structures.
CO ₃	3. Understand to handle arrays and strings
CO ₄	4. Use the 'C' language constructs in the right way using pointers, structures and unions
CO ₅	5. Design, develop and test programs written in 'C' files.

Syllabus

Course Details

Unit	Learning Units	Lecture Hours
I	Introduction to Algorithms and Programming Languages: Algorithm – Key features of Algorithms – Some more Algorithms – Flow Charts. Introduction to C: Structure of C Program – Writing the first C Program – Compiling and Executing C Programs Using Comments – Keywords – Identifiers – Basic Data Types in C – Variables Constants – I/O Statements in C- Operators in C- Programming Examples – Type Conversion and Type Casting .	12
II	Decision Control and Looping Statements: Introduction to Decision Control Statements – Conditional Branching Statements – Iterative Statements – Nested Loops – Break and Continue Statement – Go to Statement .	12
III	Functions Introduction – using functions – Function declaration/ prototype – Function definition – function call – return statement – Passing parameters – Scope of variables – Storage Classes – Recursive function	12
IV	Arrays Introduction – Declaration of Arrays – Accessing elements of the Array – Storing Values in Array Calculating the length of the Array – Operations on Array – one dimensional array for inter-function communication – Two dimensional Arrays –Operations on Two Dimensional Arrays Strings: Introduction String and Character functions	12
V	Pointers: Understanding Computer Memory – Introduction to Pointers – declaring Pointer Variables Passing Arguments to Functions using Pointer. Structure, Union, and Enumerated Data Types: Introduction – Nested Structures – Unions – Enumerated Data Types.	12

Prescribed Text Book:

1. Reema Thareja, Introduction to C programming, Oxford University Press.
2. E Balagurusamy, Computing Fundamentals & C Programming – Tata McGraw-Hill, 2008.
3. Ashok N Kamthane, Programming with ANSI and Turbo C, Pearson Publisher, 2002.
4. Henry Mulish & Hubert L.Coo Reema Thareja: The Spirit of C: An Introduction to Modern Programming, Jaico Publishing House, 1996.

Course Focus: C is a flexible language and operations in the programming process.

AG & SG SIDDHARTHA COLLEGE OF ARTS AND SCIENCES - VUYYURU.
An Autonomous college within the jurisdiction of Krishna University A.P, India.
(With Effect from Academic Year 2021-'22)

COMPUTER SCIENCE	CCSC 301C	2021-'22	B.Com.(C.A.)
-------------------------	------------------	-----------------	---------------------

SEMESTER – III

PAPER – III

Max. Marks 70

Model Paper

PROGRAMMING IN C

Pass Marks: 28

Section- A

Answer **FOUR** Questions. Each Question carries **FIVE** Marks.

4*5=20M

1. Write a short note on Algorithm?
2. Explain data types in C?
3. Write a short note on 'if' - statements?
4. Describe recursive function with an example?
5. Explain one dimensional array with example?
6. Write about pointers

Section- B

Answer **FIVE** the Questions. Each Question carries **TEN** Marks

5*10=50M

7. Explain different types of programming languages?
8. Explain about different Categories of Operators in 'C'?
9. Explain Decision Making Looping statements with examples?
10. Explain different categories of functions?
11. Explain about Storage Classes?
12. Write about two dimension arrays? Give an example program?
13. Explain briefly about String function in 'C'?
14. Difference between Structures and Unions?

AG & SG SIDDHARTHA COLLEGE OF ARTS AND SCIENCES - VUYYURU.
An Autonomous college within the jurisdiction of Krishna University A.P, India.
(With Effect from Academic Year 2021-'22)

COMPUTER SCIENCE	CCSC 301C	2021-'22	B.Com.(C.A.)
-------------------------	------------------	-----------------	---------------------

SEMESTER – III PAPER – III Max. Marks 70 Pass Marks: 28

Guidelines for paper setting 'PROGRAMMING IN C'

Unit wise weight age of Marks

	Section-A (Short answer questions)	Section-B (essay questions)
Unit-1	2	2
Unit-2	1	2
Unit-3	1	2
Unit-4	1	1
Unit-5	1	1

- Each Short answer question carries 5 marks in Section –A
- Each Essay question carries 10 marks in Section –B
- The Question papers setters are requested to cover all the topics in the syllabus stipulated as per the weight age given by us

AG & SG SIDDHARTHA COLLEGE OF ARTS AND SCIENCES - VUYYURU.
An Autonomous college within the jurisdiction of Krishna University A.P, India.
(With Effect from Academic Year 2021-22)

COMPUTER SCIENCE	CCSC-301P	2021-'22	B.Com.(C.A.)
-------------------------	------------------	-----------------	---------------------

SEMESTER – III PAPER – III Max. Marks 50 Pass Marks 20

LABLIST PROGRAMMING IN C

No. of Hours per week: 2 External: 40 Internal: 10 Credits: 2

1. Find out the given number is perfect number or not using c program.
2. Write a C program to check whether the given number is Armstrong or not.
3. Write a program to find roots of quadratic equation.
Root 1 = $(-b + \sqrt{b^2 - 4ac}) / 2a$ Root 2 = $(-b - \sqrt{b^2 - 4ac}) / 2a$
4. Write a C program to find the sum of individual digits of a positive integer.
5. Write a C program to print the Fibonacci series
6. Write a C program to generate the first n terms of the Fibonacci sequence.
7. Write a program to find factorial of a given number using recursion
8. Write a program to perform all arithmetic operations using switch case
9. Write a C program to generate all the prime numbers between 1 and n, where n is a Value supplied by the user.
10. Write a C program to find both the largest and smallest number in a list of integers.
11. Write a C program that uses functions to perform the following:
 - a. Addition of Two Matrices
 - b. Multiplication of Two Matrices
12. Write a program to perform various string operations
13. Write a program to swap two numbers using pointers.
14. Write C program that implements searching of given item in a given list
15. Write a C program to sort a given list of integers in ascending order

AG & SG SIDDHARTHA COLLEGE OF ARTS AND SCIENCES - VUYYURU.

An Autonomous college within the jurisdiction of Krishna University A.P, India.

(With Effect from Academic Year 2021-22)

Title of the Paper: PROGRAMMING IN C

Semester: I

SECTIONS: B.Sc. (MPCS / MPCS/ MSCS)

Course Code	CSCT11B	Course Delivery Method	Class Room / Blended Mode - Both
Credits	4	CIA Marks	25
No. of Lecture Hours / Week	4	Semester End Exam Marks	75
Total Number of Lecture Hours	60	Total Marks	100
Year of Introduction :2020-21	Year of Offering: 2021 - 22	Year of Revision: Nil	Percentage of Revision: 0%

Course Objective

This course aims to provide exposure to problem-solving through programming and introduce the concepts of the C Programming language.

Course Learning Outcomes:

Course Outcome No	Upon successful completion of the course, a student will be able to:	Program Outcome No.
CO1	Understand the evolution & functionality of Digital Computers and develop an algorithm for solving a given problem.	PO1, PO7, PSO1, PSO4
CO2	Understand tokens and control structures in C.	PO1, PO7, PSO1, PSO4
CO3	Understand arrays and strings and implement them.	PO1, PO7, PSO1, PSO4
CO4	Understand the right way of using functions, pointers, structures and unions in C	PO1, PO7, PSO1, PSO4
CO5	Develop and test programs written in C files	PO1, PO7, PSO1, PSO4

UNIT I

12 periods

General Fundamentals: Introduction to computers: Block diagram of a computer, characteristics and limitations of computers, applications of computers, types of computers, computer generations.

Introduction to Algorithms and Programming Languages: Algorithm – Key features of Algorithms, Flow Charts, Programming Languages – Generations of Programming Languages – Structured Programming Language- Design and Implementation of Correct, Efficient and Maintainable Programs.

UNIT II

12 periods

Introduction to C: Introduction – Structure of C Program – Writing the first C Program –File used in C Program – Compiling and Executing C Programs – Using Comments – Keywords – Identifiers – Basic Data Types in C – Variables – Constants – I/O Statements in C- Operators in C- Programming Examples.

Decision Control and Looping Statements: Introduction to Decision Control Statements– Conditional Branching Statements – Iterative Statements – Nested Loops – Break and Continue Statement – goto Statement.

UNIT III

10 periods

Arrays: Introduction – Declaration of Arrays – Accessing elements of the Array – Storing Values in Array– Operations on Arrays – one dimensional, two dimensional and multi-dimensional arrays, character handling and strings.

UNIT IV

14 periods

Functions: Introduction – using functions – Function declaration/ prototype – Function definition – function call – return statement – Passing parameters – Scope of variables – Storage Classes – Recursive functions.

Structure, Union, and Enumerated Data Types: Introduction – Nested Structures – Arrays of Structures – Structures and Functions– Union – Arrays of Unions Variables – Unions inside Structures – Enumerated Data Types.

UNIT V

12 periods

Pointers: Understanding Computer Memory – Introduction to Pointers – declaring Pointer Variables – Pointer Expressions and Pointer Arithmetic – Null Pointers - Passing Arguments to Functions using Pointer – Pointer and Arrays – Memory Allocation in C Programs – Memory Usage – Dynamic Memory Allocation – Drawbacks of Pointers

Files: Introduction to Files – Using Files in C – Reading Data from Files – Writing Data to Files – Detecting the End-of-file – Error Handling during File Operations – Accepting Command Line Arguments.

BOOKS

1. E Balagurusamy – Programming in ANSIC – Tata McGraw-Hill publications.
2. Brain W Kernighan and Dennis M Ritchie - The ‘C’ Programming language” - Pearson publications.
3. Ashok N Kamthane: Programming with ANSI and Turbo C, Pearson Edition Publications.
4. Yashavant Kanetkar - Let Us ‘C’ – BPB Publications.

RECOMMENDED CO-CURRICULAR ACTIVITIES:

(Co-curricular activities shall not promote copying from textbook or from others work and shall encourage self/independent and group learning)

A. Measurable

1. Assignments (in writing and doing forms on the aspects of syllabus content and outside the syllabus content. Shall be individual and challenging)
2. Student seminars (on topics of the syllabus and related aspects (individual activity))
3. Quiz (on topics where the content can be compiled by smaller aspects and data (Individuals or groups as teams))
4. Study projects (by very small groups of students on selected local real-time problems pertaining to syllabus or related areas. The individual participation and contribution of students shall be ensured (team activity)

B. General

1. Group Discussion
2. Try to solve MCQ’s available online.
3. Others

RECOMMENDED CONTINUOUS ASSESSMENT METHODS:

Some of the following suggested assessment methodologies could be adopted;

1. The oral and written examinations (Scheduled and surprise tests),
2. Closed-book and open-book tests,
3. Problem-solving exercises,
4. Practical assignments and laboratory reports,
5. Observation of practical skills,
6. Individual and group project reports like “Creating Text Editor in C”.
7. Efficient delivery using seminar presentations,
8. Viva voce interviews.
9. Computerized adaptive testing, literature surveys and evaluations,
10. Peers and self-assessment, outputs form individual and collaborative work

AG & SG SIDDHARTHA COLLEGE OF ARTS AND SCIENCES - VUYYURU.

An Autonomous college within the jurisdiction of Krishna University A.P, India.

(With Effect from Academic Year 2021-22)

MODEL Question Paper:

TITLE: Problem solving in C

COURSE CODE: CSCT11B

SECTIONS: B.Sc. (MPCS / MCCS/ MSCS)

SEMESTER: I

TIME: 3 Hrs.

MAX: 75M

SECTION –A

ANSWER ANY FIVE QUESTIONS

5 X 5 =25 M.

1. What is a flowchart? Utilize flowchart symbols and draw a flowchart to find biggest of two numbers. (CO1, L3)
2. Write a short note on block diagram of computers. (CO1, L2)
3. Explain do...while loop with an example program. (CO2, L2)
4. Develop a C program to find largest number in a given integer list. (CO3, L3)
5. Classify data types in C. Write a short note on any two data types. (CO2, L2)
6. How to declare and initialize 1D arrays. (CO3, L1)
7. Construct a student structure to accept student details and write a C program to calculate grade of a student. (CO4, L3)
8. Illustrate command line arguments with an example program. (CO5, L2)

SECTION – B

ANSWER ALL THE QUESTIONS

5 X 10 =50 M.

- 9 A) Define Algorithm. Demonstrate Key features of algorithm with examples. (CO1, L2)
(or)
B) List out the characteristics and limitations of computers. (CO1, L1)
- 10 A) Give Classification of Control statements in C. Explain multi-way decision making statements in C with examples. (CO2, L2)
(or)
B) Write a program to check whether the given number is Armstrong or not. (CO2, L3)
- 11 A) Develop a program in C for matrix multiplication. (CO3, L3)
(or)
B) Demonstrate various String handling functions in C with examples. (CO3, L2)
- 12 A) Compare and contrast structures with unions. (CO4, L4)
(or)
B) Explain the types of functions in C. (CO4, L2)
- 13 A) List different file handling functions in C. Explain with examples. (CO5, L2)
(or)
B) Explain call by value and call by reference with example. (CO4, L2)

AG & SG SIDDHARTHA COLLEGE OF ARTS AND SCIENCES - VUYYURU.

An Autonomous college within the jurisdiction of Krishna University A.P, India.

(With Effect from Academic Year 2021-22)

BLUE PRINT

TITLE: Problem solving in C

COURSE CODE: CSCT11B

SECTIONS: B.Sc. (MPCS / MCCS / MSCS)

SEMESTER: I

TIME: 3 Hrs.

MAX: 75M

SECTION-A

ANSWER ANY FIVE QUESTIONS

5X5=25M

1. Unit 1
2. Unit 1
3. Unit 2
4. Unit 3
5. Unit 2
6. Unit 3
7. Unit 4
8. Unit 5

SECTION – B

ANSWER ALL THE QUESTIONS

5 X 10 =50 M.

9 A) Unit 1.

(or)

B) Unit 1.

10 A) Unit 2.

(or)

B) Unit 2.

11 A) Unit 3.

(or)

B) Unit 3.

12 A) Unit 4.

(or)

B) Unit 4.

13 A) Unit 5.

(or)

B) Unit 5.

AG & SG SIDDHARTHA COLLEGE OF ARTS AND SCIENCES - VUYURU.

An Autonomous college within the jurisdiction of Krishna University A.P, India.

(With Effect from Academic Year 2021-22)

Semester I	Course Code	Course Title	Credits	Prd s
B.Sc.(MPCS / MCCS/ MSCS)	CSCP11B	Problem Solving in C Lab	1	30

Course Outcome No	Upon successful completion of this course, students should have the knowledge and skills to:	Program Outcome No
CO1	Apply logical skills to analyse a given problem	PO1, PO7, PSO1, PSO4, PSO2
CO2	Design an algorithmic solution for a given problem	PO1, PO7, PSO1, PSO4, PSO2
CO3	Write a maintainable C program according to coding standards for a given algorithm	PO1, PO7, PSO1, PSO4, PSO2
CO4	Debug a given program	PO1, PO7, PSO1, PSO4, PSO2
CO5	Execute the C program	PO1, PO7, PSO1, PSO4, PSO2

**Experiments List
Cycle-I**

Week 1:

Write a C program to check whether the given two numbers are equal, bigger or smaller?

Week 2:

Write a C program to perform arithmetic operations using Switch...case?

Week 3:

- Write a program to find the sum of individual digits of a positive integer.
- Write a program to check whether the given number is Armstrong or not.

Week 4:

Write a program to generate the first N terms of the Fibonacci sequence.

Week 5:

Write a program to find both the largest and smallest number in a list of integer values

Week 6:

- Write a program that uses functions to add two matrices.
- Write a program for multiplication of two n X n matrices.

Week 7:

Write a program to demonstrate reflection of parameters in swapping of two integer values using Call by Value & Call by Address.

Week 8:

Write a program to calculate factorial of given integer value using recursive functions.

Cycle-II

Week 9:

Write a program to search an element in a given list of values.

Week 10:

Write a program to illustrate pointer arithmetic.

Week 11:

Write a program to sort a given list of integers in ascending order.

Week 12:

Write a program to calculate the salaries of all employees using Employee (ID, Name, Designation, Basic Pay, DA, HRA, Gross Salary, Deduction, Net Salary) structure.

- a. DA is 30 % of Basic Pay
- b. HRA is 15% of Basic Pay
- c. Deduction is 10% of (Basic Pay + DA)
- d. Gross Salary = Basic Pay + DA+ HRA
- e. Net Salary = Gross Salary - Deduction

Week 13:

Write a program to perform various string operations.

Week 14:

Write a program to read the data character by character from a file.

Week 15:

Write a program to create Book (ISBN, Title, Author, Price, Pages, Publisher) structure and store book details in a file and perform the following operations

- a. Add book details
- b. Search a book details for a given ISBN and display book details, if available
- c. Update a book details using ISBN
- d. Delete book details for a given ISBN and display list of remaining Books.

AG & SG SIDDHARTHA COLLEGE OF ARTS AND SCIENCES - VUYYURU.

An Autonomous college within the jurisdiction of Krishna University A.P, India.

(With Effect from Academic Year 2021-22)

Title of the Paper: INFORMATION TECHNOLOGY

Semester: I

SECTIONS: B.Com (CA)

Course Code	CSBT11A	Course Delivery Method	Class Room / Blended Mode - Both
Credits	4	CIA Marks	25
No. of Lecture Hours / Week	5	Semester End Exam Marks	75
Total Number of Lecture Hours	60	Total Marks	100
Year of Introduction :2020-21	Year of Offering: 2021 - 22	Year of Revision: Nil	Percentage of Revision: 0%

INFORMATION TECHNOLOGY

Objective:

It provides to learn computer basics and basic principles of using Windows operation system and be able to access the Internet, data communication, Software, hardware and various new technologies in information technology.

Course Outcomes:

COURSE OUTCOME NO	Upon successful completion of this course, students should have the knowledge and skills to
CO1	Understand fundamental concepts of a computer and its basic components
CO2	Understand basic functioning of an operating system and customizing Windows Desktop
CO3	Analyse type of soft wares and programming languages
CO4	Have knowledge in basic Network and Data Communication Concepts
CO5	Understand the need of data mining and get familiarize with basics of new concepts like KDD, OLAP

UNIT-I: INTRODUCTION:

13Periods

- 1.1 Introduction to computers
- 1.2 Generations of computers
- 1.3 An overview of computer system - Types of computers
- 1.4 Input & Output Devices.
- 1.5 Hardware: Basic components of a computer system- Control unit– ALU- Input/output functions.
- 1.6 Memory – RAM – ROM – EPROM - PROM and Other types of memory.

UNIT-II: OPERATING SYSTEM (OS):

12Periods

- 2.1 Meaning - Definition & Functions.
- 2.2 Types of OS - Booting process
 - 2.2.1 DOS – Commands (internal & external) - Wild card characters
- 2.3 Windows: Using the Start Menu –Control Panel – Using multiple
 - 2.3.1 Windows – Customizing the Desktop – Windows accessories (Preferably latestversion of windows or Linux Ubuntu).

Unit-III: SOFTWARE:

15Periods

- 3.1 System software and application software.
 - 3.1.1 Operating system windows OS,
 - 3.1.2 Mobile device operating system and notebook operating systems
- 3.2 Application software Types of personal application software

3.2.1 Spread sheet-data management

3.2.2 Word processing

3.2.3 Desktop publishing

3.2.4 Graphics, CAD, CAM, CIM

3.3 Programming Languages

3.3.1 Assembly language

3.3.2 Procedural language, non-procedural language, natural programming language.

3.3.3 Hypertext mark-up language, modelling language, object-oriented programming language.

Unit-IV: DATA COMMUNICATION:

20 Periods

4.1 Telecommunication and Networks Communication media& channel cable media

4.1.1 Broad cast media channels twisted pair

4.1.2 Coaxial cable, fibers optical cable, micro wave, satellite, radio, cellular radio, infrared global positioning system.

4.2 Introduction, Analog and Digital signals, modulation need of modulations, modems.

4.3 Telecommunication System communication processors:

4.3.1 Modem

4.3.2 Multiplexers

4.3.3 Front –end-processor.

4.4 Networks LAN, WAN, VAN, virtual private network (VPN).

4.5 Internet, intranet and Extranets

4.5.1 The evolution of the internet, service provided by the internet, World Wide Web.

Unit-V: NEW TECHNOLOGIES:

10 Periods

5.1 New technologies in Information Technology:

5.1.1 Introduction to hyper media, artificial intelligence and business intelligence, knowledge discovery in database (KDD)

5.2 Data warehouse and data marts. Data mining and OLAP.

Student Activity:

Students have to submit assignments and give seminars on various topics allotted to them.

Total of 5 Hrs is allotted for student seminars. Student activity also includes gathering of information related to latest technologies in computers.

Library Activity:

Students will visit library in their allotted time and will refer various text books to gather information for their assignments.

TEXT/ REFERENCE BOOKS:

1. B.E.V.L.Naidu, V.V.. Devi Prasad Konti, Ganti Naga Srikanth, Himalaya publishing House.
2. Introduction to Computers: Peter Norton, McGraw Hill

AG & SG SIDDHARTHA COLLEGE OF ARTS AND SCIENCES - VUYYURU.

An Autonomous college within the jurisdiction of Krishna University A.P, India.

(With Effect from Academic Year 2021-22)

MODEL Question Paper:

PAPER TITLE: Problem solving in C

COURSE CODE: CABT11A

CLASS: B.Com (Computer Applications)

SEMESTER: I

TIME: 3 Hrs.

MAX: 75M

SECTION – A

Answer any five of the following

5X5 =25M

1. Illustrate the characteristics of RAM and ROM. (CO1, L2)
2. Define Operating system. What are different types of OS? (CO2, L1)
3. Demonstrate application software and system software. (CO3, L2)
4. What are the different types of networks? (CO4, L1)
5. Explain the steps involved in the process of KDD. (CO5, L2)
6. Explain about input devices. (CO1, L2)
7. What are analog and digital signals? (CO4, L1)
8. Explain Data warehouse. (CO5, L2)

SECTION –B

Answer the following

5x10=50M

9. a) Explain the block diagram of computer. (CO1, L2)

OR

- b) Explain the generations of computers. (CO1, L2)

10. a) What are the functions of operating system? (CO2, L1)

OR

- b) What are DOS Internal and External commands? (CO2, L1)

11. a) Explain the characteristics of various types of programming languages. Give examples. (CO3, L2)

OR

- b) Summarize the concepts on CAD, CAM and CIM. (CO3, L2)

12. a) Define the various types of Communication media and channels. (CO4, L1)

OR

- b) What are the Advantages and Disadvantages of Internet? (CO4, L1)

13. a) Demonstrate On-Line Analytical process (OLAP). (CO5, L2)

OR

- b) Explain about Artificial Intelligence and Business Intelligence. (CO5, L2)

AG & SG SIDDHARTHA COLLEGE OF ARTS AND SCIENCES - VUYYURU.

An Autonomous college within the jurisdiction of Krishna University A.P, India.

(With Effect from Academic Year 2021-22)

Title of the Paper: E-Commerce & Web Designing

Semester: I

SECTIONS: B.Com B.Com (E-Commerce -Computers)

Course Code	CSCT11B	Course Delivery Method	Class Room / Blended Mode - Both
Credits	3	CIA Marks	25
No. of Lecture Hours / Week	4	Semester End Exam Marks	75
Total Number of Lecture Hours	60	Total Marks	100
Year of Introduction :2020-21	Year of Offering: 2021 - 22	Year of Revision: Nil	Percentage of Revision: 0%

COURSE OBJECTIVES:

The main objective of the course is to impart conceptual understanding on business transactions on worldwide web and electronic commerce & Electronic Customer Relationship Management and Web designing concepts for providing quality content on website.

COURSE OUTCOMES:

COURSE OUTCOME NO	Upon successful completion of this course, students should have the knowledge and skills to
CO1	Understand the structure of HTML its basic tags
CO2	Implement various HTML tags for web page development
CO3	Understand about implementing forms and frames in web page designing
CO4	Gain knowledge in E- commerce and its business models
CO5	Differentiate traditional and e – marketing and also gain knowledge in E-CRM and EPS

UNIT I: Introduction to Web Designing

(12Hrs)

1.1 Introduction

1.2 1.1.1 WWW and its Evaluation

1.1.2 Define network and its advantages

1.1.3 Types of networks

1.1.4 Network Topologies

1.2 HTML

1.2.1 Define HTML

1.2.2 Structure of HTML

1.2.3 Basic HTML tags

1.2.4 Formatting HTML tags

UNIT II: HTML Tags

(12Hrs)

2.1: Lists

2.1.1 Ordered List

2.1.2 Unordered List

2.2 Links

2.2.1 Link tag

2.2.2 image tag

2.2.3 Marquee tag

2.3 Tables

- 2.3.1 Table Creation
- 2.3.2 Attributes of Table

UNIT III: Forms and Frames and CSS

(12Hrs)

3.1 forms

- 3.1.1 forms creation
- 3.1.2 form tag
- 3.1.3 input fields of form

3.2 Frames

- 3.2.1 Frame Creation
- 3.2.2 Frameset tag
- 3.2.3 frame tag

3.3 Cascading Style Sheets

- 3.3.1 Introduction to CSS
- 3.3.1 Types of CSS
- 3.3.2 in-line Style Sheet
- 3.3.3 internal Style Sheet
- 3.3.4 External Style Sheet

UNIT IV: An Overview on E-Commerce

(10Hrs)

4.1.1 Introduction E-Commerce

- 1. Definition of E- Commerce and its advantages & disadvantages
- 2. Electronic Data Interchange (EDI)
- 3. E-Commerce transactional issues and challenges
- 4.1.4 Difference between Commerce and E-Commerce

4.2 Business Models for Ecommerce

- 1. B2C -Business to consumer.
- 2. B2B – Business to business
- 3. C2B – Consumer to business.
- 4. C2C – Consumer to consumer.

UNIT V: E-Marketing &E – CRM& Electronic Payment Systems

(14Hrs)

5.1 Online Marketing

- 1. Traditional Vs. E-Marketing
- 5.1.2 Online Marketing
- 5.1.3 E-Advertising
- 5.1.4 Internet marketing

5.2 E – CRM

- 5.2.1** Definition of CRM and E-CRM and its Applications
- 5.2.2 E- CRM Architectural components
- 5.2.3 Definition & characteristics of E- SCM
- 5.2.4 Benefits and goals of E – SCM
- 5.2.5 E-Logistics of UPS

5.3 Electronic Payment Systems

- 5.3.1 Types of EPS
- 5.3.2 Traditional payment system and modern payment system
- 5.3.3 Steps for electronic payment
- 5.3.4 Payment security

Text Book:

- 1. Uttam Kumar Roy, Web Technologies, Oxford University Press.
- 2. E-Commerce- A Managerial Perspective- P. T. Joseph, Prentice- Hall of India, New Delhi, 2005.

References:

- 1. Kogent Learning Solutions Inc.(Author), “Black Book HTML 5.0”, dreamtech.
- 2. Daniel Amor, E-Bussiness R(Evolution), Pearson Edude, New Delhi, 2005.

AG & SG SIDDHARTHA COLLEGE OF ARTS AND SCIENCES - VUYYURU.
An Autonomous college within the jurisdiction of Krishna University A.P, India.
(With Effect from Academic Year 2021-22)

<i>Computer Science</i>	CSCT11B	2021-22	B.Com (E-Commerce -Computers)
-------------------------	----------------	----------------	--------------------------------------

Semester-I

Credits: 1

WEB DESIGNING LAB

COURSE OBJECTIVES:

The purpose of this course is to introduce to students to the field of creation web pages using HTML language. The students will be able to enhance their analyzing and help to creation for Web Site Design

COURSE OUTCOMES:

COURSE OUTCOME NO	Upon successful completion of this course, students should have the knowledge and skills to
CO1	Implement HTML tags.
CO2	Implementing lists and tables in web pages.
CO3	Implementing frames in web pages.
CO4	Implementing frames in web pages.
CO5	Creation of CSS in a web page.

1. Write a HTML program to print text in bold and italic font.
2. Write a HTML program to print Heading tags.
3. Write a HTML program using Text formatting tags
3. Write a HTML program to implement unordered lists.
4. Write a HTML program to implement order lists.
5. Write a html file which display 3 images at LEFT, RIGHT and CENTER respectively in the browser.
- 6 Create a HTML file which contains hyperlinks.
- 7 Write a HTML program to create a table
8. Write a HTML program to create a table using Row Span and Cols pan
9. Write a HTML program to create a table using cell padding and Row Spacing
10. Write a HTML program to create a simple form
11. Create a Registration form that interacts with the user. Collect login name, password, date of birth, gender, address, qualification.
12. Create a HTML page using frameset tag.
- 13Write a Program to create an inline style sheet.
14. Write a program to create Embedded Style Sheet.
15. Write a program to create an external style sheet to illustrate the “Font” elements.

AG & SG SIDDHARTHA COLLEGE OF ARTS AND SCIENCES - VUYYURU.
An Autonomous college within the jurisdiction of Krishna University A.P, India.
(With Effect from Academic Year 2021-22)

E-Commerce & Web Designing
Model Question Paper

Class: B.Com (E-Commerce -Computers)

Course Code: CSCT11B

Semester: I

Max Marks: 75 M

Time: 3Hours

Section-A

ANSWER ANY FIVE QUESTIONS

5X5M=25M

1. Define Networks and its types? (CO3, L1)
2. Explain Link tags in HTML (CO4, L2)
3. Define frames in HTML (CO5, L1)
4. Explain the E-Commerce (CO1, L2)
5. Compare Traditional marketing and E-Marketing. (CO2, L2)
6. Demonstrate concept of formatting Tags (CO4, L2)
7. Compare Commerce and E-Commerce. (CO1, L2)
8. Explain Benefits and goals of E – SCM. (CO2, L2)

Section-B

ANSWER THE FOLLOWING QUESTIONS

5X10M=50M

9. (A) Define Structure of HTML with examples (CO3, L1)

(OR)

- (B) What are different types Network Topologies? (CO3, L1)

- 10.(A) Classify List Types in HTML. (CO4, L2)

(OR)

- (B) Demonstrate the concept of Table creation with apply all Attributes. (CO4, L2)

- 11.(A) Define forms in html and creation of form with all input types? (CO5, L1)

(OR)

- (B)What are different types of CSS with suitable examples? (CO5, L1)

- 12 (A) Explain EDI. (CO1, L2)

(OR)

- (B) Classify Business Models for Ecommerce. (CO1, L2)

13. (A) Illustrate E- CRM Architectural components. (CO2, L2)

(OR)

- (B) Explain Electronic Payment Systems. (CO2, L2)

A.G & S.G SIDDHARTHA DEGREE COLLEGE OF ARTS & SCIENCE, VUYYURU-521165

(An Autonomous College in the Jurisdiction of Krishna University)

Accredited at the level 'A' by the NAAC

Sponsors: Siddhartha Academy of General & Technical Education



DEPARTMENT OF COMPUTER SCIENCE

Minutes of the meeting of Board of Studies in Computer Science for PG (M.Sc.)

Date: 25th November 2021



A.G & S.G SIDDHARTHA DEGREE COLLEGE OF ARTS & SCIENCE VUYYURU-521165

(An Autonomous College in the Jurisdiction of Krishna University)

Accredited at the level 'A' by the NAAC

Sponsors: Siddhartha Academy of General & Technical Education

DEPARTMENT OF COMPUTER SCIENCE

Minutes of the meeting of Board of Studies in Computer Science for PG held on 25th November 2021 in the Department of Computer Science.

Members Present		
Name of the Member	Role	Signature
Sri. T.Naga Prasada Rao, I/C HOD, Dept of Computer Science, A.G & S.G Siddhartha Degree College of Arts & Science, Vuyyuru-521165. Mobile: 9866803938, E-Mail: t.nagaprasadarao@gmail.com	Chairman	
Dr. K. Madhavi, Associate Professor, Dept of Computer Science, JNTUA. College of Engineering, Anantapur. Mobile: 9440206501 E-Mail: kasamadhavi@yahoo.com	University Nominee, Krishna University	
Dr. R. Satya Prasad, Professor, Department of Computer Science, Acharya Nagarjuna University, Nagarjuna Nagar-522508. Mobile: 9848487478 E-Mail: profrsp@gmail.com	Subject Expert	
Dr. T. S. Ravi Kiran, H.O.D & Assistant Professor, Dept of Computer Science, P.B. Siddhartha Degree College of Arts & Science - Vijayawada -520002. Mobile: 9441176980 E-Mail: kirantsr1@gmail.com, tsravikiran@pbsiddhartha.ac.in	Special Invitee	
Mr. U. Sairam, C.E.O, Codegnan I.T Solutions OPC PVT LTD., Vijayawada520002 Mobile: 9959555952 E-Mail: uppugundlasairam@gmail.com	Industrialist	
Mr. Korada Sri Venkata Siva Sai Kumar, Software Developer, GGS Information Services India Pvt., Ltd. Mobile: 8686541443 E-Mail: svkorada@gmail.com	Alumni Representative	
Mrs. T. Keerthi, Assistant Professor, Dept. of Computer Science, A.G & S.G Siddhartha Degree College of Arts & Science, Vuyyuru-521165. Mobile: 9959558485 E-Mail: keerthitatineni16@gmail.com	Member	
Mr. K.Srikanth, Assistant Professor, Dept. of Computer Science, A.G & S.G Siddhartha Degree College of Arts & Science, Vuyyuru-521165. Mobile: 9182188521 E-Mail: srikanth.agsgs@gmail.com	Member	
Mrs. V. Munni, Assistant Professor, Dept. of Computer Science, A.G & S.G Siddhartha Degree College of Arts & Science, Vuyyuru-521165. Mobile: 8099205522 E-Mail: munni.j2ee@gmail.com	Member	
Mr. V. Naga Malleswararao, Assistant Professor, Dept. of Computer Science, A.G & S.G Siddhartha Degree College of Arts & Science, Vuyyuru-521165. Mobile: 9505582600, E-Mail: nagamalliv14@gmail.com	Member	

BOS Meeting – P.G Department of Computer Science-25/11/2021, 10.00 AM, through online Mode (Google Meet) A.G& S.G Siddhartha Degree College of Arts & Science.

Syllabus approval letter through Mail

1. Associate Professor Dr. K. Madhavi,

Dear Sir/Madam,

I Approve the Structure, Syllabi and Model Question Papers for the First & Third Semester of M.Sc Computer Science , which were discussed in the Bos Meeting held on 25/11/2021.

Dr K. Madhavi,

Associate Professor,

Dept. of CSE,

JNTUA College of Engineering, Ananthapuramu

Mobile: 9440206501

E-Mail: kasamadhavi@yahoo.com

2. Professor Dr. R. Satya Prasad,

Dear Sir/Madam,

I Approved minutes of BOS of all resolutions 25th November 2021

Dr. R. Satya Prasad,

Professor,

Department of Computer Science,

Acharya Nagarjuna University,

Nagarjuna Nagar-522508.

Mobile: 9848487478

E-Mail: profrsp@gmail.com

3. Dr. T. S. Ravi Kiran, Assistant Professor,

Dear Sir

I Approved Minutes of BOS

Dr. T. S. Ravi Kiran,

Assistant Professor

Dept of Computer Science,

P.B. Siddhartha Degree College of Arts & Science

Vijayawada -520002.

Mobile: 9441176980

E-Mail: kirantsr1 @gmail.com,

tsravikiran@pbsiddhartha.ac.in

AGENDA

- To discuss and approve the Structure, Syllabi and Model Question Papers of First Semester of M.Sc.(Computer Science) for the batch of students admitted from the academic year 2021-2022 and onwards.
- To discuss and approve the Structure, Syllabi and Model Question Papers of Third Semester of M.Sc.(Computer Science) for the batch of students admitted from the academic year 2021-2022 and onwards.
- To discuss and approve the Structure, Syllabi and Model Question Papers of Open Electives “Visual Analytics for Executives” and “Web Programming”.
- To discuss and approve the Structure, Syllabi and Model Question Paper of Add on Course “PHP with My SQL Certification (21CS3A1)” for M.Sc.(Computer Science) Programme.

RECOMMENDATIONS FOR M.Sc.(COMPUTER SCIENCE) PROGRAMME

- Resolved and recommended to adopt the Structure, Syllabi and Model Question Papers of First Semester of M.Sc.(Computer Science) Programme inline with the guidelines of OBE following the Bloom’s Taxonomy for the batch of students admitted from the academic year 2021-2022 and onwards. Refer Appendix-I for First Semester Structure, Syllabi and Model Question Papers as per the new regulations recommended by the Krishna University with effect from 2021-2022(R20).
- Resolved and recommended to adopt the Structure, Syllabi and Model Question Papers of Third Semester of M.Sc.(Computer Science) Programme inline with the guidelines of OBE following the Bloom’s Taxonomy for the batch of students admitted from the academic year 2020-2021 and onwards. Refer Appendix-II for Third Semester Structure, Syllabi and Model Question Papers as per the new regulations recommended by the Krishna University with effect from 2020-2021(R20).

RECOMMENDATIONS FOR OPEN ELECTIVES

- Resolved and recommended to adopt the Syllabi and Model Question Papers of open electives “Visual Analytics for Executives” and “Web Programming”. Refer Appendix-III for Syllabi and Model Question Papers.

RECOMMENDATIONS FOR ADD ON COURSE

- It is resolved and recommended that grades for Add on Course “PHP with My SQL Certification” (20CS3A1) are awarded as per the rule applicable to any course part of M.Sc.(Computer Science) Programme. Refer Appendix-IV.

Program Educational Objectives & Program Specific Objectives

Program Educational Objectives for M.Sc.(Computer Science) Programme

PEO1. Technical Expertise and Knowledge in Multiple Domains: Ability to develop an understanding of modern computing concepts and architectures from a design and performance perspective of various domains.

PEO2. Assessment from System Level Perspective: Able to analyse and appreciate the structure of computer systems and the processes involved in their construction at various levels of detail and abstraction.

PEO3. Critical Thinking, Business Analytics & Problem Solving and Innovation: An ability to apply knowledge of mathematics and computer science practices to build Innovative Public & Private Sector Applications involving complex computing problem solving and in research.

PEO4. Professional Ethics & Social Responsibility: Ability to apply and commit to professional ethics following cyber regulations in a global economic environment. Create and design innovative applications to solve complex problems using established practices for the betterment of the society.

PEO5. Apposite to Industry: Gain exposure to multiple programming languages, tools, paradigms, and technologies as well as the fundamental underlying principles throughout their education there by making them the right choice for industry positions.

PEO6. Effective Communication & Leadership: Ability to communicate effectively and present technical & project management information using audio visual tools as well as in oral and written reports. Rise up to the need and be able to lead teams of individuals.

PEO7. Life-long Learning and Research: Understand the importance of, and possess pre-requisite skill set to undertake life-long independent learning and research in the context of contemporary technological advancements.

Program Specific Objectives for M.Sc.(Computer Science) Programme

PSO1. To make the students industry ready as far as possible to enhance their employability in the industries.

PSO2. Create an ambience of education through faculty training, self learning, sound academic practices and research endeavors.

Appendix-I

First Semester *Structure, Syllabi & Model Question Papers* of M.Sc(Computer Science) Programme. (For the batch of Students admitted during the Academic Year 2021-2022)

Applicable for the batch of students admitted during the Academic Year 2021-2022										
M.Sc.(Computer Science)						SEMESTER I				
S.No.	Course Code	Title of the Course	Instruction Hours per Week			Credits	Evaluation			Total Marks
			L	T	P		CIA Marks	SEE		
								Marks	Duration	
1	21CS1T1	Problem Solving Using Python Programming	4			4	30	70	3 Hours	100
2	21CS1T2	Computer Organization	4			4	30	70	3 Hours	100
3	21CS1T3	Software Engineering	4			4	30	70	3 Hours	100
4	21CS1T4	Database Management Systems	4			4	30	70	3 Hours	100
5	21CS1T5	Theory of Computation	4			4	30	70	3 Hours	100
6	21CS1L1	Problem Solving Using Python Programming Lab			8	4	30	70	3 Hours	100
7	21CS1L2	DBMS Lab			8	4	30	70	3 Hours	100
8	21CS1S1	Seminar	2			1	50	Nil	Nil	50
Total			38			29	260	490		750
CIA=Continuous Internal Assessment						SEE=Semester End Examinations				

Applicable for the batch of students admitted during the Academic Year 2021-2022										
M.Sc.(Computer Science)						SEMESTER III				
S.No.	Course Code	Title of the Course	Instruction Hours per Week			Credits	Evaluation			Total Marks
			L	T	P		CIA Marks	SEE		
								Marks	Duration	
1	21CS3T1	Cryptography & Network Security	4			4	30	70	3 Hours	100
2	21CS3T2	Design & Analysis of Algorithms	4			4	30	70	3 Hours	100
3	21CS3T3	Web Technologies	4			4	30	70	3 Hours	100
4	21CS3T4	Data Mining Techniques	4			4	30	70	3 Hours	100
5		Open Elective-II (Student has to select one open elective from the elective courses provided)	4			4	30	70	3 Hours	100
6	21CS3L1	Web Technologies Lab			8	4	30	70	3 Hours	100
7	21CS3L2	Data Mining Lab			8	4	30	70	3 Hours	100
Total			36			28	210	490		700
CIA=Continuous Internal Assessment						SEE=Semester End Examinations				

A.G & S.G Siddhartha Degree College of Arts & Science, Vuyyuru – 521165.
(An Autonomous College in the jurisdiction of Krishna University)
M.Sc., (Computer Science) Programme - I Semester

Course	PROBLEM SOLVING USING PYTHON PROGRAMMING		
Course Code	21CS1T1	Course Delivery Method	Class Room / Blended Mode
Credits	4	CIA Marks	30
No. of Lecture Hours / Week	4	Semester End Exam Marks	70
Total Number of Lecture Hours	60	Total Marks	100
Year of Introduction:2020-21	Year of Offering:2021-22	Year of Revision:2021-22	Percentage of Revision: 0%

Course Outcomes:On successful completion of this course, the students:

1. Understand basics of Python Programming. (CO1)
2. Gain knowledge on Decision Control Statements and Functions & Modules. (CO2)
3. Be familiar with Python Strings and Data Structures. (CO3)
4. Have knowledge on Classes & Objects. (CO4)
5. Apply Inheritance, Error and Exception Handling and Operator Overloading. (CO5)

Unit	Learning Units	Lecture Hours
I	Basics of Python Programming: Features of Python, History of Python, The Future of Python, Writing and Executing First Python Program, Literal Constants, Variables and Identifiers, Data Types, Input Operation, Comments, Reserved Words, Indentation, Operators and Expressions, Expressions in Python, Operations on Strings, Other Data Types, Type Conversion.	14
II	Decision Control Statements: Conditional Branching Statements, Basic Loop Structures, Nested Loops, The Break Statement, The Continue Statement, The Pass Statement. The Else Statement used with Loops. Functions and Modules: Function Definition, Function Call, Variable Scope and Lifetime, The Return Statement, More on Defining Functions, Recursive Functions, Modules, Packages in Python, Standard Library Modules.	14
III	Python Strings Revisited: Concatenating, Appending and Multiplying Strings, String Formatting Operator, Built in String Methods and Functions, Comparing Strings, Regular Expressions. Data Structures: Sequence, Lists, Functional Programming, Tuple, Sets, Dictionaries.	10
IV	Classes and Objects: Classes and Objects, Class Method and self Argument, Class Variables and Object Variables, Public and Private Data Members, Private Methods, Calling a Class Method from Another Class Method, Built-in Class Attributes, Class Methods, Static Methods.	10
V	Inheritance: Inheriting Classes in Python, Types of Inheritance, Abstract Classes and Interfaces. Error and Exception Handling: Introduction to Errors and Exceptions, Handling Exceptions, Raising Exceptions, Built-in and User defined Exceptions Operator Overloading: Concept of Operator Overloading, Advantage of Operator Overloading, Implementing Operator Overloading.	12

Prescribed Text Book

	Author	Title	Publisher
1	Reema Thareja	Python Programming Using Problem Solving Approach	Oxford University Press

Reference Text Book

1	Wesley Chun	Core Python Programming	Prentice Hall
---	-------------	-------------------------	---------------

Time: 3 Hours

Answer ALL questions

Max. Marks: 70

(10×2 = 20 Marks)

1. a) Define Comments and Operators. (BTL1)
- b) Define Indentation. (BTL1)
- c) What is Dangling else Problem? (BTL1)
- d) What is a Package? (BTL1)
- e) What is a Slice? (BTL1)
- f) Define Immutable. (BTL1)
- g) What is Class Variable and Instance Variable? (BTL1)
- h) What is Namespace? (BTL1)
- i) Differentiate Error and Exception? (BTL3)
- j) What is Membership Operator? (BTL1)

Answer Five Questions Choosing One Question from Each Unit.

All Questions Carry Equal Marks.

(5×10 = 50 Marks)

UNIT – I

2. A) Explain the features of Python Programming Language. (BTL2)
- (or)**
- B) Explain Different Types of Operators in Python. (BTL2)

UNIT – II

3. A) Discuss Basic Loop Structures in Python with illustrations. (BTL6)
- (or)**
- B) Explain Modules in Python with examples. (BTL2)

UNIT – III

4. A) State built-in String Methods and Functions in Python. (BTL1)
- (or)**
- B) Explain Tuple Data Structure in Python with examples. (BTL2)

UNIT – IV

5. A) What are Classes and Objects? Write a program in Python to illustrate an instance variable. (BTL1)
- (or)**
- B) Explain Class Method and Static Method with example. (BTL2)

UNIT – V

6. A) Explain Different Types of Inheritance in Python with suitable examples. (BTL2)
- (or)**
- B) Explain any three Built-in Exceptions with relevant examples. (BTL2)

A.G & S.G Siddhartha Degree College of Arts & Science, Vuyyuru – 521165.
(An Autonomous College in the jurisdiction of Krishna University)
M.Sc., (Computer Science) Programme - I Semester

Course	COMPUTER ORGANIZATION		
Course Code	21CS1T2	Course Delivery Method	Class Room / Blended Mode
Credits	4	CIA Marks	30
No. of Lecture Hours / Week	4	Semester End Exam Marks	70
Total Number of Lecture Hours	60	Total Marks	100
Year of Introduction:2020-21	Year of Offering:2021-22	Year of Revision:2021-22	Percentage of Revision: 0%

Course Outcomes:

On successful completion of this course, the students:

1. Understand Digital Logic Circuits, Digital Components and Data Representation. (CO1)
2. Know Register Transfer and Micro Operations and Basic Computer Organization and Design. (CO2)
3. Be familiar with Micro Programmed Control and Central Processing Unit. (CO3)
4. Have knowledge on Computer Arithmetic. (CO4)
5. Understand Input-Output Organization & Memory Organization. (CO5)

Unit	Learning Units	Lecture Hours
I	Digital Logic Circuits: Digital Computers, Logic Gates, Boolean Algebra, Map Simplification, Combinational Circuits, Flip-Flops, Sequential Circuits. Digital Components: Integrated Circuits, Decoders, Multiplexers, Registers, Shift Registers, Binary Counters, Memory Unit. Data Representation: Data Types, Complements, Fixed-Point Representation, Floating-Point Representation, Other Binary Codes, Error Detection Codes.	14
II	Register Transfer and Micro Operations: Register Transfer Language, Register Transfer, Bus & Memory Transfers, Arithmetic Micro Operations, Logic Micro Operations, Shift Micro Operations, Arithmetic Logic Shift Unit. Basic Computer Organization and Design: Instruction Codes, Computer Registers, Computer Instructions, Timing & Control, Instruction Cycle, Memory-Reference Instructions, Input-Output Interrupt.	14
III	Micro Programmed Control: Control Memory, Address Sequencing, Micro Program Example, Design of Control Unit. Central Processing Unit: General Register Organization, Stack Organization, Instruction Formats, Addressing Modes, Data Transfer and Manipulation, Program Control.	14
IV	Computer Arithmetic: Introduction, Addition and Subtraction, Multiplication Algorithm, Floating Point Arithmetic Operations, Decimal Arithmetic Unit, Decimal Arithmetic Operations.	08
V	Input-Output Organization: Peripheral Devices, Input-Output Interface, Asynchronous Data Transfer, Modes of Transfer, Priority Interrupt. Memory Organization: Memory Hierarchy, Main Memory, Auxiliary Memory, Associative Memory, Cache Memory.	10

Prescribed Text Book			
	Author	Title	Publisher
1	M.Morris Mano	Computer System Architecture	3 rd Edition, Pearson Education (2008).

Reference Text Books			
	Author	Title	Publisher
1	V. Rajaraman, T. Radha Krishnan	Computer Organization and Architecture	PHI
2	Behrooz Parhami	Computer Architecture	Oxford (2007)
3	ISRD group	Computer Organization	Ace series, TMH (2007)
4	William Stallings	Computer Organization and Architecture – Designing for Performance	Pearson Education (2005)
5	P.Chakraborty	Computer Architecture and Organization	Jaico Books (2008)

A.G & S.G Siddhartha Degree College of Arts & Science, Vuyuru – 521165.
(An Autonomous College in the jurisdiction of Krishna University)
M.Sc., (Computer Science) Programme - I Semester
Course Code: 21CS1T2 Title: COMPUTER ORGANIZATION
(w.e.f admitted batch 2021-22)

Time: 3 Hours

Max. Marks: 70
(10×2 = 20 Marks)

Answer ALL questions

1. a) State any two Logic Gates with Truth Tables. (BTL1)
- b) Find the Binary Number (?)₂ to Hexadecimal Number (1C)₁₆ (BTL1)
- c) What is Register Transfer? (BTL1)
- d) What is Accumulator ? (BTL1)
- e) What is Address Sequencing ? (BTL1)
- f) Give details of Stack Organization. (BTL1)
- g) What is BCD Adder ? (BTL1)
- h) Perform Binary Multiplication for the decimal numbers 23 and 19. (BTL1)
- i) What is the difference between Isolated and Memory Mapped I/O? (BTL1)
- j) What is Priority Interrupt ? (BTL1)

Answer Five Questions Choosing One Question from Each Unit.

All Questions Carry Equal Marks.

(5×10 = 50 Marks)

UNIT – I

2. A) What is Flip flop? Explain different types of Flip flops in detail. (BTL1)
- (or)
- B) Explain the Fixed Point Representation with an example. (BTL2)

UNIT – II

3. A) Explain Logic Micro Operations in detail. (BTL2)
- (or)
- B) What is Instruction Cycle? Explain various phases of Instruction Cycle. (BTL1)

UNIT – III

4. A) Describe the design of Control Unit. (BTL2)
- (or)
- B) Explain various Addressing Modes. (BTL2)

UNIT – IV

5. A) What is BCD Added ? Explain in detail. (BTL1)
- (or)
- B) Explain Booth's Multiplication Algorithm with example. (BTL2)

UNIT – V

6. A) Explain different Modes of Data Transfers. (BTL2)
- (or)
- B) What is Cache Memory? Discuss various Mapping Procedures of Cache Memory. (BTL1)

A.G & S.G Siddhartha Degree College of Arts & Science, Vuyyuru – 521165.
(An Autonomous College in the jurisdiction of Krishna University)
M.Sc., (Computer Science) Programme - I Semester

Course	SOFTWARE ENGINEERING		
Course Code	21CS1T3	Course Delivery Method	Class Room / Blended Mode
Credits	4	CIA Marks	30
No. of Lecture Hours / Week	4	Semester End Exam Marks	70
Total Number of Lecture Hours	60	Total Marks	100
Year of Introduction:2021-22	Year of Offering:2021-22	Year of Revision:2021-22	Percentage of Revision: 0%

Course Outcomes: On successful completion of this course, the students:

1. Understand various Software Engineering Methods, Practices, Process Models and Agile Development Strategies. (CO1)
2. Illustrate Core Principles, Requirements & Modelling Concepts. (CO2)
3. Identify different Software Testing Approaches and various aspects of Software Quality Assurance. (CO3)
4. Classify various Process & Project Management Concepts. (CO4)
5. Estimate Software Projects & apply Formal Methods Modelling. (CO5)

Unit	Learning Units	Lecture Hours
I	<p>Software and Software Engineering: The Nature of Software: Defining Software, Software Application Domains, Legacy Software, The Unique Nature of WebApps, Software Engineering, The Software Process, Software Engineering Practices: The Essence of Practice, General Principles, Software Myths.</p> <p>Process Models: A Generic Process Model: Defining a Framework Activity, Identifying a Task Set, Process Patterns, Process Assessment and Improvement, Prescriptive Process Models: The Waterfall Model, Incremental Process Models, Evolutionary Process Models, Concurrent Models, A Final Word on Evolutionary Processes, Specialized Process Models: Component-Based Development, The Formal Methods Model, Aspect-Oriented Software Development, The Unified Process: A Brief History, Phases of the Unified Process, Personal and Team Process Models: Personal Software Process (PSP), Team Software Process (TSP). Agile Development: What Is Agility, Agility and the Cost of Change, What Is an Agile Process: Agility Principles, The Politics of Agile Development, Human Factors, Extreme Programming (XP): XP Values, The XP Process, Industrial XP, The XP Debate, Other Agile Process Models: Adaptive Software Development (ASD), Scrum, Dynamic Systems Development Method (DSDM), Crystal, Feature Driven Development (FDD), Lean Software Development (LSD), Agile Modeling (AM), Agile Unified Process (AUP).</p>	12
II	<p>Principles that Guide Practice: Core Principles: Principles That Guide Process, Principles That Guide Practice, Principles That Guide Each Framework Activity: Communication Principles, Planning Principles, Modeling Principles, Construction Principles, Deployment Principles. Requirements Modeling: Scenarios, Information, and Analysis Classes: Requirements Analysis: Overall Objectives and Philosophy, Analysis Rules of Thumb, Domain Analysis, Requirements Modeling Approaches, Scenario-Based Modeling: Creating a Preliminary Use Case, Refining a Preliminary Use Case, Writing a Formal Use Case, UML Models That Supplement the Use Case: Developing an Activity Diagram, Swimlane Diagrams. Data Modeling Concepts: Data Objects, Data Attributes, Relationships, Class-Based Modeling: Identifying Analysis Classes, Specifying Attributes, Defining Operations, Class-Responsibility-Collaborator (CRC) Modeling, Associations and Dependencies, Analysis Packages.</p>	12

III	<p>Software Quality Assurance: Background Issues, Elements of Software Quality Assurance, SQA Tasks, Goals, and Metrics: SQA Tasks, Goals, Attributes, and Metrics, Formal Approaches to SQA, Statistical Software Quality Assurance: A Generic Example, Six Sigma for Software Engineering, Software Reliability: Measures of Reliability and Availability, Software Safety, The ISO 9000 Quality Standards, The SQA Plan.</p> <p>Software Testing Strategies: A Strategic Approach to Software Testing: Verification and Validation, Organizing for Software Testing, Software Testing Strategy-The Big Picture, Criteria for Completion of Testing, Strategic Issues, Test Strategies for Conventional Software: Unit Testing, Integration Testing, Test Strategies for Object-Oriented Software: Unit Testing in the OO Context, Integration Testing in the OO Context, Test Strategies for WebApps, Validation Testing: Validation-Test Criteria, Configuration Review, Alpha and Beta Testing, System Testing: Recovery Testing, Security Testing, Stress Testing, Performance Testing, Deployment Testing, The Art of Debugging: The Debugging Process, Psychological Considerations, Debugging Strategies, Correcting the Error</p> <p>Testing Conventional Applications: Software Testing Fundamentals, Internal and External Views of Testing, White-Box Testing, Basis Path Testing: Flow Graph Notation, Independent Program Paths, Deriving Test Cases, Graph Matrices, Control Structure Testing: Condition Testing, Data Flow Testing, Loop Testing, Black-Box Testing: Graph-Based Testing Methods, Equivalence Partitioning, Boundary Value Analysis, Orthogonal Array Testing,</p>	12
IV	<p>Project Management Concepts: The Management Spectrum: The People, The Product, The Process, The Project, People: The Stakeholders, Team Leaders, The Software Team, Agile Teams, Coordination and Communication Issues, The Product: Software Scope, Problem Decomposition, The Process: Melding the Product and the Process, Process Decomposition, The Project, The W5HH Principles. Process and Project Metrics: Metrics in the Process and Project Domains: Process Metrics and Software Process Improvement, Project Metrics, Software Measurement: Size-Oriented Metrics, Function-Oriented Metrics, Reconciling LOC and FP Metrics, Object-Oriented Metrics, Use-Case-Oriented Metrics, WebApp Project Metrics, Metrics for Software Quality: Measuring Quality, Defect Removal Efficiency</p>	12
V	<p>Formal Modeling And Verification: The Cleanroom Strategy, Functional Specification: Black-Box Specification, State-Box Specification, Clear-Box Specification, Cleanroom Design: Design Refinement, Design Verification, Cleanroom Testing: Statistical Use Testing, Certification, Formal Methods Concepts, Applying Mathematical Notation for Formal Specification, Formal Specification Languages: Object Constraint Language (OCL), The Z Specification Language. Estimation for Software Projects: Resources: Human Resources, Reusable Software Resources, Environmental Resources, Software Project Estimation, Decomposition Techniques: Software Sizing, Problem-Based Estimation, An Example of LOC-Based Estimation, An Example of FP-Based Estimation, Empirical Estimation Models: The Structure of Estimation Models, The COCOMO II Model, The Software Equation, Estimation for Object-Oriented Projects.</p>	12

Prescribed Text Book

	Author	Title	Publisher
1	Roger S Pressman	Software Engineering - A Practitioner's Approach	Seventh Edition, McGraw - Hill, A Business Unit of The McGraw-Hill Companies, Inc.,

Reference books

1	Sommerville	Software engineering	7 th edition, Pearson
2	S.A.Kelkar	Software Engineering - A Concise Study	PHI.
3	Waman S.Jawadekar	Software Engineering	TMH.

A.G & S.G Siddhartha Degree College of Arts & Science, Vuyyuru – 521165.
(An Autonomous College in the jurisdiction of Krishna University)
M.Sc., (Computer Science) Programme - I Semester
Course Code: 21CS1T3 Title: SOFTWARE ENGINEERING
(w.e.f admitted batch 2021-22)

Time: 3 Hours

Answer ALL questions

Max. Marks: 70
(10×2 = 20 Marks)

1. a) Define Software Engineering. (BTL1)
- b) What is PSP & TSP? (BTL2)
- c) Write any two key features of Class-Responsibility-Collaborator (CRC) Modeling. (BTL1)
- d) State any two Deployment Principles. (BTL1)
- e) What is Software Reliability? (BTL1)
- f) Describe the Arts of Debugging. (BTL2)
- g) What are the aspects to be considered while testing Object Oriented Software? (BTL1)
- h) Write any two W5HH Principles. (BTL1)
- i) State various Resources while estimating the Software Projects. (BTL1)
- j) What is State Box? (BTL1)

Answer Five Questions Choosing One Question from Each Unit.

All Questions Carry Equal Marks.

(5×10 = 50 Marks)

UNIT – I

2. A) What is Myth? State various myths of Software Myths. (BTL1)
- (or)
- B) Describe any two Prescriptive Process Models. (BTL2)

UNIT – II

3. A) State (i) Communication and (ii) Planning Principles. (BTL1)
- (or)
- B) Describe Scenario-Based Modeling in detail. (BTL2)

UNIT – III

4. A) Discuss the testing strategies to test Conventional Software. (BTL2)
- (or)
- B) What is White Box Testing? Explain in detail. (BTL1)

UNIT – IV

5. A) Discuss the Management Spectrum in detail. (BTL6)
- (or)
- B) Explain (i) Size-Oriented Metrics and (ii) Function-Oriented Metrics in detail. (BTL2)

UNIT – V

6. A) Explain Functional Specification of Cleanroom Strategy. (BTL2)
- (or)
- B) Describe (i) The COCOMO II Model and (ii) The Software Equation of Empirical Estimation Models. (BTL2)

A.G & S.G Siddhartha Degree College of Arts & Science, Vuyuru – 521165.
(An Autonomous College in the jurisdiction of Krishna University)
M.Sc., (Computer Science) Programme - I Semester

Course	DATABASE MANAGEMENT SYSTEMS		
Course Code	21CS1T4	Course Delivery Method	Class Room / Blended Mode
Credits	4	CIA Marks	30
No. of Lecture Hours / Week	4	Semester End Exam Marks	70
Total Number of Lecture Hours	60	Total Marks	100
Year of Introduction:2020-21	Year of Offering:2021-22	Year of Revision:2021-22	Percentage of Revision: 0%

Course Outcomes:

On successful completion of this course, the students:

1. Understands the Concepts & Architecture of Databases. (CO1)
2. Able to apply simple and complex SQL Queries & Relational Algebra & Relational Calculus operations. (CO2)
3. Gain knowledge on ER, EER Schemas & Normalization. (CO3)
4. Understands Disk Storage Organization, Hashing & Indexing. (CO4)
5. Be aware of Transaction Processing, Concurrency Control and Distributed Databases. (CO5)

Unit	Learning Units	Lecture Hours
I	<p>Databases and Database Users: Introduction, An Example, Characteristics of the Database Approach, Actors on the Scene, Workers behind the Scene, Advantage of Using the DBMS Approach.</p> <p>Database System Concepts and Architecture: Data Models, Schemas, and Instances, Three-Schema Architecture and Data Independence, Database Languages and Interfaces, The Database System Environment, Centralized and Client/Server Architectures for DBMSs.</p> <p>The Relational Data Model and Relational Database Constraints: Relational Model Concepts, Relational Model Constraints and Relational Database Schemas, Update Operations, Transactions, and Dealing with Constraint Violations.</p>	12
II	<p>Basic SQL: SQL Data Definition and Data Types, Specifying Constraints in SQL, Basic Retrieval Queries in SQL, INSERT, DELETE, and UPDATE Statements in SQL.</p> <p>More SQL: More Complex SQL Retrieval Queries, Views (Virtual Tables) in SQL, Schema Change Statements in SQL.</p> <p>The Relational Algebra and Relational Calculus: Unary Relational Operations: SELECT and PROJECT, Relational Algebra Operations from Set Theory, Binary Relational Operations: JOIN and DIVISION, Additional Relational Operations, Examples of Queries in Relational Algebra, The Tuple Relational Calculus, The Domain Relational Calculus.</p>	10
III	<p>Data Modeling Using the Entity-Relationship (ER) Model: Using High-Level Conceptual Data Models for Database Design, Entity Types, Entity Sets, Attributes, Keys, Relationship Types, Relationship Sets, Roles, Structural Constraints, Weak Entity Types, ER Diagrams, Naming Conventions, Design Issues.</p> <p>The Enhanced Entity-Relationship (EER) Model: Subclasses, Super classes, Inheritance, Specialization and Generalization, Constraints and Characteristics of Specialization and Generalization Hierarchies, Modeling of UNION Types Using</p>	14

	<p>Categories, A Sample UNIVERSITY EER Schema, Design Choices, Formal Definitions.</p> <p>Functional Dependencies: Introduction, Basic Definitions, Trivial and Non-Trivial Dependencies, Closure of set of Dependencies, Closure of set of Attributes, Irreducible sets of dependencies.</p> <p>Further Normalization 1NF, 2NF, 3NF, BCNF: Introduction, Nonloss decomposition and functional dependencies, 1st, 2nd and 3rd normal forms, Boyce-Codd Normal Form. Multivalued Dependency and Fourth Normal Form, Join Dependencies and Fifth Normal.</p>	
IV	<p>Disk Storage, Basic File Structures and Hashing: Secondary Storage Devices, Buffering of Blocks, Placing File Records on Disk, Operations on Files, Files of Unordered Records (Heap Files), Files of Ordered Records (Sorted Files), Hashing Techniques, Parallelizing Disk Access Using RAID Technology.</p> <p>Indexing Structures for Files: Types of Single-Level Ordered Indexes, Multilevel Indexes, Dynamic Multilevel Indexes Using B-Trees and B⁺-Trees.</p>	10
V	<p>Introduction to Transaction Processing Concepts and Theory: Introduction to Transaction Processing, Transaction and System Concepts, Desirable Properties of Transactions, Characterizing Schedules Based on Recoverability, Characterizing Schedules Based on Serializability, Transaction Support in SQL.</p> <p>Concurrency Control Techniques: Two-Phase Locking Techniques for Concurrency Control, Concurrency Control Based on Timestamp Ordering, Multiversion Concurrency Control Techniques, Validation (Optimistic) Concurrency Control Techniques, Granularity of Data Items and Multiple Granularity Locking, Using Locks for Concurrency Control in Indexes.</p> <p>Distributed Databases: Distributed Database Concepts, Types of Distributed Database Systems, Distributed Database Architectures, Data Fragmentation, Replication and Allocation Techniques for Distributed Database Design.</p>	14

Prescribed Text Book

	Author	Title	Publisher
1	Ramez Elmasri, Shamkant B. Navathe	Fundamentals of Database Svstems.	Pearson Education, Seventh Edition, 2017
2	C.J. Date, A.Kannan, S.Swamynathan	An Introduction to Database Svstems	VII Edition Pearson Education (2006).

Reference Text Books

	Author	Title	Publisher
1	Peter Rob, Carlos Coronel	Database Systems - Design, Implementation and Management	Eigth Edition, Thomson (2008)
2	Raman A Mata - Toledo, Panline K. Cushman	Database Management Systems	Schaum's Outlines, TMH (2007)
3	Steven Feuerstein	Oracle PL/SQL - Programming	10 th Anniversary Edition, OREILLY (2008)

A.G & S.G Siddhartha Degree College of Arts & Science, Vuyyuru – 521165.
(An Autonomous College in the jurisdiction of Krishna University)
M.Sc., (Computer Science) Programme - I Semester
Course Code: 21CS1T4 Title: DATABASE MANAGEMENT SYSTEMS
(w.e.f admitted batch 2021-22)

Time: 3 Hours

Max. Marks: 70

Answer ALL questions

(10×2 = 20 Marks)

1. a) What is Data Independence? (BTL1)
- b) What is Primary Key? (BTL1)
- c) Write example for Update Command. (BTL1)
- d) What is Join Condition? Explain with example. (BTL1)
- e) What is Weak Entity? (BTL1)
- f) What is First Normal Form. (BTL1)
- g) What is Heap File. (BTL1)
- h) Write advantage of using Multilevel Indexes? (BTL1)
- i) Write Properties of Transaction. (BTL1)
- j) What is Data Fragmentation? (BTL1)

Answer Five Questions Choosing One Question from Each Unit.

All Questions Carry Equal Marks.

(5×10 = 50 Marks)

UNIT – I

2. A) What is DBMS? Explain advantage of DBMS. (BTL1)
(or)
B) Explain Three Schema Architecture of DBMS with neat diagram. (BTL2)

UNIT – II

3. A) What is Constraint? Explain various Constraints of the Relational Model. (BTL1)
(or)
B) Describe SELECT & PROJECT Operations of Relational Algebra. (BTL2)

UNIT – III

4. A) What is Generalization? Explain with example. (BTL1)
(or)
B) What is BCNF? Explain with example. (BTL1)

UNIT – IV

5. A) What is Hashing? Describe Internal & External Hashing Techniques.
(or)
B) What is B-Tree? Construct B-Tree for the values 10, 20, 30, 40, 50, 60, 70, 80, 90 of order 3.

UNIT – V

6. A) Explain Concurrency Control Based on Timestamp Ordering. (BTL2)
(or)
B) Explain Distributed Database Concepts in detail. (BTL2)

A.G & S.G Siddhartha Degree College of Arts & Science, Vuyyuru – 521165.
(An Autonomous College in the jurisdiction of Krishna University)
M.Sc., (Computer Science) Programme - I Semester

Course	THEORY OF COMPUTATION		
Course Code	21CS1T5	Course Delivery Method	Class Room / Blended Mode
Credits	4	CIA Marks	30
No. of Lecture Hours / Week	4	Semester End Exam Marks	70
Total Number of Lecture Hours	60	Total Marks	100
Year of Introduction:2020-21	Year of Offering:2021-22	Year of Revision:2021-22	Percentage of Revision: 0%

Course Outcomes:

On successful completion of this course, the students:

1. Understand Fundamentals of Automata and Finite Automata. (CO1)
2. Able to apply Regular Languages. (CO2)
3. Gain knowledge on Grammar Formalism and Context Free Grammars. (CO3)
4. Design Pushdown Automata. (CO4)
5. Understand Turing Machine and Computability Theory. (CO5)

Unit	Learning Units	Lecture Hours
I	Fundamentals: Strings, Alphabet, Language, Operations, Finite Automaton Model, Acceptance of Strings and Languages, FA, Transition Diagrams and Language Recognizers. Finite Automata: Deterministic Finite Automaton, Non Deterministic Finite Automaton (Simple Problems), Differences between NFA and DFA, NFA with ϵ Transitions- Significance of NFA with Epsilon, Acceptance of Language, Conversions and Equivalence-Conversion from NFA with ϵ to NFA without ϵ , NFA to DFA Conversion, NFA with ϵ to DFA, Minimization of FSM, Equivalence between two FSMs, Equivalence of Moore and Mealy Machines.	14
II	Regular Languages: Regular Sets, Regular Expressions, Identity Rules for Regular Expression, Conversion of Finite Automata (DFA) to Regular Expressions - using State Elimination Method and Arden's Theorem, Conversion of Regular Expression to ϵ -NFA, Pumping Lemma of Regular Languages (Sets) (Proofs Not Required).	10
III	Grammar Formalism: Regular Grammars - Right Linear and Left Linear Grammars, Inter Conversion- Conversion of a Regular Grammar for a given Finite Automata, Construct FA from Regular Grammar, Context Free Grammar, Derivation Trees, Sentential Forms, Right most and Leftmost Derivation of Strings. Context Free Grammars: Ambiguity in Context Free Grammars. Minimization of Context Free Grammars. Chomsky Normal Form, Greibach Normal Form, Pumping Lemma for Context Free Languages, Enumeration Properties of CFL (Proofs Not Required), Simple Problems	14
IV	Push Down Automata: Definition, Model, Design of PDA, Acceptance by Final State and Acceptance by Empty Stack, Inter Conversion - Construct PDA Equivalent to a given CFL, Construct CFL Equivalent to a given PDA (Proofs Not Required).	08
V	Turing Machine: Definition, Model, Design of TM, Recursively Enumerable Languages and its Properties and Recursive Languages, Types of Turning Machines: Simple Problems. Computability Theory: Chomsky Hierarchy of Languages: Regular Grammars, Unrestricted Grammars, Context Sensitive Languages, Decidability of Problems: Properties of Recursive and Recursively Enumerable Languages, Universal Turing Machine, Undecidability of Posts Correspondence Problem, Definition of NP Complete and NP Hard Problems.	14

Prescribed Text Book			
	Author	Title	Publisher
1	Hopcroft H.E. and Ullman	Introduction to Automata Theory Languages and Computation	J. D. Pearson Education

Reference Text Books			
	Author	Title	Publisher
1	John C Martin	Introduction to languages and the Theory of Computation	TMH
2	A.A Putumbekar	Formal Languages and Automata Theory	Technical Publications
3	Lewis H.P. & Papadimitriou C.H	Elements of Theory of Computation	Pearson PHI
4	Mishra and Chandrashekar	Theory of Computer Science and Automata Languages and Computation	2 nd edition, PHI.
5	Daniel I.A. Cohen	Introduction to Computer Theory	John Wiley

Time: 3 Hours

Max. Marks: 70

Answer ALL questions

(10×2 = 20 Marks)

1.

- a) Define Alphabet. (BTL1)
- b) Find ϵ -closure of all states for the given Transition Diagram. (BTL1)

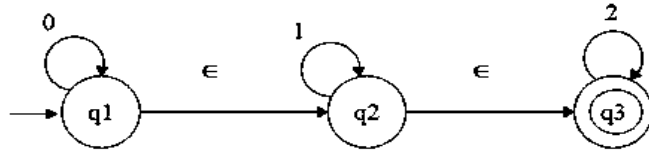

c) Define Regular Expression and Regular Set

with example (BTL1)

d) Write Regular Expression which denotes a language L over the set $\Sigma = \{0\}$ having even length of string.

e) Define Parse Tree with example. (BTL1)

f) Show that the grammar is ambiguous (BTL2)

$$S \rightarrow a \mid sA \mid \mid bSS \mid \mid SSb \mid \mid SbS \mid$$

g) Give the formal definition of Push Down Automata. (BTL1)

h) Define Deterministic PDA. (BTL1)

i) What are Recursively Enumerable Languages? (BTL1)

j) Define Turing Machine. (BTL1)

Answer Five Questions Choosing One Question from Each Unit.

All Questions Carry Equal Marks.

(5×10 = 50 Marks)

UNIT – I

2. A) Convert the given NFA to DFA. (BTL3)

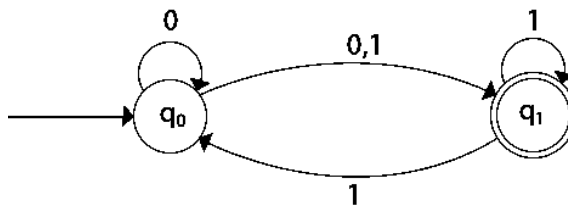

(or)

B) Construct the minimum DFA for the following Transition Diagram. (BTL3)

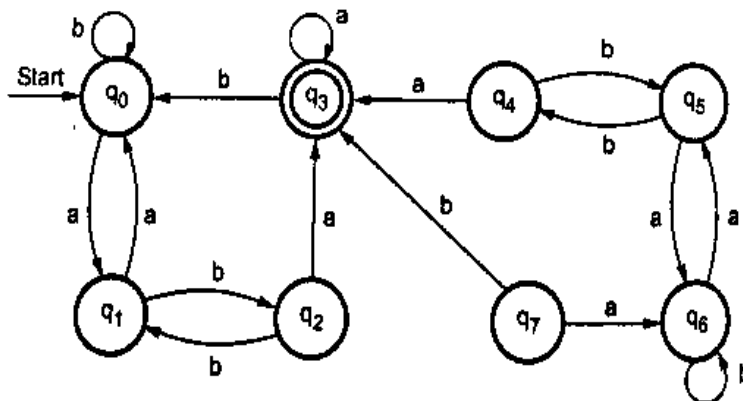

UNIT – II

3. A) Construct epsilon NFA for Regular Expression $1+00+010^*$ (BTL3)

(or)

B) Find Regular Expression for the following DFA using State Elimination Method. (BTL1)

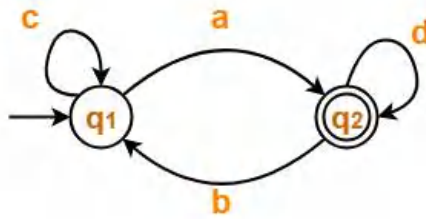

UNIT – III

4. A) Drive the string “aabbabba” for Leftmost Derivation and Rightmost Derivation using a CFG given by (BTL5)

$S \rightarrow aB \mid bA$

$A \rightarrow a \mid aS \mid bAA$

$B \rightarrow b \mid bS \mid aBB$

(or)

B) For the following grammar, construct CNF (BTL3)

$S \rightarrow ABC \mid BbB$

$A \rightarrow aA \mid BaC \mid aaa$

$B \rightarrow bBb \mid a \mid D$

$C \rightarrow CA \mid AC$

$D \rightarrow \epsilon$

i) Eliminate ϵ -productions.

ii) Eliminate any unit productions in the resulting grammar.

iii) Eliminate any useless symbols in the resulting grammar.

UNIT – IV

5. A) Convert the following Context Free Grammar to Push Down Automata (BTL3)

$S \rightarrow AA \mid a$

$A \rightarrow SA \mid b$

(or)

B) The PDA is as given below (BTL3)

$A = (\{q_0, q_1\}, \{0,1\}, \{S,A\}, \delta, q_0, S, \emptyset)$

Where δ is as given below

$\delta(q_0, 1, S) = \{(q_0, AS)\}$

$\delta(q_0, \epsilon, S) = \{(q_0, \epsilon)\}$

$\delta(q_0, 1, A) = \{(q_0, AA)\}$

$\delta(q_0, 0, A) = \{(q_1, A)\}$

$\delta(q_0, 1, A) = \{(q_1, \epsilon)\}$

$\delta(q_0, 0, S) = \{(q_0, S)\}$

Construct the CFG equivalent to this PDA.

UNIT – V

6. A) Design a Turing Machine for the Language $L = \{a^n b^n c^n \mid n \geq 1\}$ (BTL6)

(or)

B) Define PCP and also find the correspondence system as given below

$A = (1, 0, 010, 11)$ and $B = (10, 10, 01, 1)$ the input set is $\Sigma = \{0, 1\}$ find the solution. (BTL1)

A.G & S.G Siddhartha Degree College of Arts & Science, Vuyyuru – 521165.
(An Autonomous College in the jurisdiction of Krishna University)
M.Sc., (Computer Science) Programme - I Semester

Course	PROBLEM SOLVING USING PYTHON PROGRAMMING LAB		
Course Code	21CS1L1	Course Delivery Method	Class Room / Blended Mode
Credits	4	CIA Marks	30
No. of Lecture Hours / Week	8	Semester End Exam Marks	70
Total Number of Lecture Hours	90	Total Marks	100
Year of Introduction :2020-21	Year of Offering:2021-22	Year of Revision:2021-22	Percentage of Revision: 0%

Course Outcomes:

On successful completion of this course, the students:

1. Understand basics of Python Programming. (CO1)
2. Gain knowledge on Decision Control Statements and Functions & Modules. (CO2)
3. Be familiar with Python Strings and Data Structures. (CO3)
4. Apply Inheritance, Error and Exception Handling and Operator Overloading. (CO4)
5. Able to connect Database and perform Database Access. (CO5)

1. Write a python program to enter a number and display its hex and octal equivalent and its square root.
2. WAP to read and print values of variables of different data types.
3. WAP
 - a. To calculate area of a triangle using herons formula.
 - b. To calculate the distance between two points.
 - c. To calculate the area of the circle.
4. WAP to perform addition, subtraction, multiplication, division, integer division, and modulo division on two integer numbers.
5. WAP to calculate the total amount of money in the piggybank, given the coins of Rs10, Rs 5, Rs 2 and Rs1.
6. WAP to calculate the bill amount for an item given its quantity sold, value, discount and tax.
7. WAP to calculate a students result based on two examinations, 1 sports event and 3 activities conducted. The weightage of activities=30 percent, sports=20 percent and examination=50 percent.
8. WAP to convert a floating point number into the corresponding integer.
9. A company decides to give bonus to all its employees on diwali. 5% bonus on salary is given to the male workers and 10% bonus on salary to the female workers. WAP to enter the salary of the employee and gender of the employee gets an extra 2% bonus on salary. Calculate the bonus that has to be given to the employee and display the salary that the employee will get.
10. WAP to calculate tax given the following conditions:

If income is less than 1,50,000 then no tax

If taxable income is 1,50,001 – 300,000 then charge 20% tax

If taxable income is above 5,00,001 then charge 30% tax

MIN1 = 150001

MAX1= 300000

RATE1 = 0.10

MIN2 = 300001

MAX2=500000

RATE2=0.20

MIN3=500001

RATE3=0.30

11. WAP to calculate the roots of quadratic equation.
12. WAP to make a simple calculator.
13. WAP to print the calendar of any given year.
14. WAP to calculate simple interest .suppose the customer is a senior citizen. He is being offered 12% interest for all customers the ROI is 10% using functions.
15. WAP to display the date and time using the time module.
16. Write a python program to perform inheritance.
17. Write a Python program to perform exception handling.
18. WAP to demonstrate slice operation on string objects.
19. a. WAP to calculate fib(n) using a dictionary.
b. to create a dictionary cubes of odd numbers in the range 1 to 10.
20. WAP to parse an emailed to print from which email server it was sent and when.
21. WAP to perform operations on stack.
22. WAP to perform read and write operations in files.
23. WAP that accepts filename as an input from an user open a file count a number of times a character appears in the file.
24. Write a program on modules.
25. Write a program to perform image operations.
26. Write a GUI for an expression calculator using tk.
27. Write a program to print text from the audio file. (Speech to Text and using speech_recognition library).
28. Write a program to connect database and create a table using SQLite.
29. Write a program to perform insertion and selection operation using SQLite.

A.G & S.G Siddhartha Degree College of Arts & Science, Vuyuru – 521165.
(An Autonomous College in the jurisdiction of Krishna University)
M.Sc., (Computer Science) Programme - I Semester

Course	DBMS LAB		
Course Code	21CS1L2	Course Delivery Method	Class Room / Blended
Credits	4	CIA Marks	30
No. of Lecture Hours / Week	8	Semester End Exam Marks	70
Total Number of Lecture Hours	90	Total Marks	100
Year of Introduction :2020-21	Year of Offering:2021-22	Year of Revision:2021-22	Percentage of Revision: 0%

Course Outcomes:

1. Create Database using DDL Commands. (CO1)
2. Retrieve Data from database using DML for a given situation. (CO2)
3. Familiarize with a Query Language through basic SQL Queries. (CO3)
4. Experiment Nested Query, Joins, Integrity Constraints and Views in database. (CO4)
5. Demonstrate Trigger, Function and Procedure using PL/SQL. (CO5)

CYCLE-I

Aim: Marketing Company wishes to computerize their operations by using following tables.

Table Name: Client- Master		Description: Used to store client information	
Column Name	Data Type	Size	Attribute
CLIENT_NO	Varchar2	6	Primary key and first letter must start
NAME	Varchar2	20	Not null
ADDRESS 1	Varchar2	30	
ADDRESS S	Varchar2	30	
CITY	Varchar2	15	
PINCODE	Varchar2	8	
STATE	Varchar2	15	
BAL_DUE	Number	10,2	

Table Name: Product_Master		Description: Used to store product information	
Column Name	Data Type	Size	Attribute
PRODUCT_NO	Varchar2	6	Primary key and first letter must start
DESCRIPTION	Varchar2	15	Not null
PROFIT_PERCENT	Number	4,2	Not null
UNIT_MEASUE	Varchar2	10	
QTY_ON_HAND	Number	8	
REORDER_LVL	Number	8	
SELL_PRICE	Number	8, 2	Not null, cannot be 0
COST_PRICE	Number	8,2	Not null, cannot be 0

Table Name: Salesman_Master		Description: Used to store salesman information working for the company.	
Column Name	Data Type	Size	Attribute
SALESMAN_NO	Varchar2	6	Primary key and first letter must start with 'S'
SALESMAN_NAME	Varchar2	20	Not null
ADDRESS1	Varchar2	30	
ADDRESS2	Varchar2	30	
CITY	Varchar2	20	
PINCODE	Number	8	

STATE	Vachar2	20	
SAL_AMT	Number	8,2	Not null, cannot be 0
TGT_TO_GET	Number	6,2	Not null, cannot be 0
YTD_SALES	Number	6,2	Not null
REMARKS	Vachar2	20	

Table Name: Sales_Order			
Description: Used to store client's orders			
Column Name	Data Type	Size	Attribute
ORDER_NO	Vachar2	6	Primary key and first letter must start with
CLIENT_NO	Vachar2	6	Foreign Key
ORDER_DATE	Date		
DELY_ADDRESS	Vachar2	25	
SALESMAN_NO	Vachar2	6	Foreign Key
DELY_TYPE	Char	1	Delivery: part(p)/ full(f) and default 'F'
BILL_YN	Char	1	
DELY_DATE	Date		Can't be less than order date
ORDER_STATUS	Vachar2	10	Values ("In Process", "Fulfilled",

Table Name: Sales_Order_Details			
Description: Used to store client's order with details of each product ordered.			
Column Name	Data Type	Size	Attribute
ORDER_NO	Vachar2	6	Primary key references SALES_ORDER
PRODUCT_NO	Vachar2	6	Foreign Key references
QTY_ORDERED	Number	8	
QTY_DISP	Number	8	
PRODUCT_RATE	Number	10,2	Foreign Key

Solve the following queries by using above tables.

1. Retrieve the list of names, city and the state of all the clients.
2. List all the clients who are located in 'Mumbai' or 'Bangalore'.
3. List the various products available from the product_master table.
4. Find the names of sales man who have a salary equal to Rs.3000.
5. List the names of all clients having 'a' as the second letter in their names.
6. List all clients whose Bal due is greater than value 1000.
7. List the clients who stay in a city whose first letter is 'M'.
8. List all information from sales-order table for orders placed in the month of July.
9. List the products whose selling price is greater than 1000 and less than or equal to 3000.
10. Find the products whose selling price is greater than 1000 and also find the new selling price as original selling price 0.50.
11. Find the products in the sorted order of their description.
12. Find the products with description as '540HDD' and 'Pen drive'.
13. Count the total number of orders.
14. Print the description and total qty sold for each product.
15. Calculate the average qty sold for each client that has a maximum order value of 15,000.
16. Find all the products whose quantity on hand is less than reorder level.
17. List the order number and day on which clients placed their order.
18. Find out the products and their quantities that will have to deliver in the current month.
19. Find the names of clients who have placed orders worth of 10000 or more.
20. Find the client names who have placed orders before the month of June,2018.

CYCLE-II

Aim: A manufacturing company deals with various parts and various suppliers supply these parts. It consists of three tables to record its entire information. Those are as follows.

Supplier (Supplier_No, Sname, City, status)

Part(Part_no, pname, color, weight, city, cost)

Shipment (supplier_No, Part_no, city)

JX(project_no, project_name, city)

SPJX (Supplier_no, part_no, project_no, city)

Solve the following queries by using above tables.

1. Get supplier numbers and status for suppliers in Chennai with status > 20.
2. Get project names for projects supplied by supplier S.
3. Get colors of parts supplied by supplier S₁.
4. Get part numbers for parts supplied to any project in Mumbai.
5. Find the id's of suppliers who supply a red or pink parts.
6. Find the pnames of parts supplied by London supplier and by no one else.
7. Get the names of the parts supplied by the supplier 'Mart' and 'Miller'.
8. Get supplier names for suppliers who do not supply part P₂.
9. Get all pairs of supplier numbers such that the suppliers concerned are "colocated".
10. Get suppliers names for the suppliers who supply at least one red part.

CYCLE-III

Aim: An enterprise wishes to maintain a database to automate its operations. Enterprise divided into a certain departments and each department consists of employees. The following two tables describes the automation schemas.

Emp(Empno, Ename, Job, Mgr, Hiredate, Sal, Comm, Deptno)

Dept(Deptno, Dname, Loc)

Solve the following queries by using above tables.

1. List the details of employees who have joined before the end of September' 81.
2. List the name of the employee and designation of the employee, who does not report to anybody.
3. List the name, salary and PF amount of all the employees (PF is calculated as 10% of salary)
4. List the names of employees who are more than 2 years old in the organization.
5. Determine the number of employees, who are taking commission.
6. Update the employee salary by 20% , whose experience is greater than 12 years.
7. Determine the department does not contain any employees.
8. Create a view, which contains employee name and their manager names working in sales department.
9. Determine the employees, whose total salary is like the minimum salary of any department.
10. List the department numbers and number of employees in each department.
11. Determine the employees, whose total salary is like the minimum salary of any department.
12. List average salary for all departments employing more than five people.
13. Determine the names of employees, who take highest salary in their departments.
14. Determine the names of employees, who earn more than their managers.
15. Display ename, dname, even if no employee belongs to that department (use outer join).

CYCLE-IV

An Airline system would like to keep track their information by using the following relations.

FLIGHTS(fl_no: integer, from: string, to: string, distance: integer, price: integer)

AIRCRAFT(aid: integer, aname: string, cruising_range: integer)

CERTIFIED(eid: integer, aid: integer)
Employees(eid: integer, ename: string, salary: real)

Note that the employees relation describes pilots and other kinds of employees as well; every pilot is certified for aircraft and only pilots are certified to fly. Resolve the following queries.

- a) Find the names of pilots whose salary is less than the price of the cheapest route from Newyork to Chicago.
- b) For each pilot who is certified for more than 2 aircraft, find the eid's and the maximum cruising range of the aircraft that he or she certified for.
- c) For all aircraft with cruising range over 1,500 miles, find the name of the aircraft and the average salary of all pilots certified for this aircraft.
- d) Find the aid's of all aircraft than can be used from chicaga to LosAngels.
- e) Find the name of the pilots certified from some Boeing aircraft.
- f) Print the enames of pilots who can operate planes with cruising range greater than 3,500 miles, but are not certified by Boeing aircraft.
- g) Find the eid's of employees who are certified for exactly 2 aircrafts.
- h) Find the total amount paid to employees as salaries.
- i) Find the aid's of all than can be used on non-stop flights from Chennai to Dubai.
- j) Find the eid's of employee who make second highest salary.

PL/SQL PROGRAMS

1. Write a PL/SQL program to check the given number is strong or not.
2. Write a PL/SQL program to check the given string is palindrome or not.
3. Write a PL/SQL program to swap two numbers without using third variable.
4. Writ a PL/SQL program to generate multiplication tables for 2, 4, 6.
5. Write a PL/SQL program to check the given number is Armstrong or not.
6. Write a PL/SQL code to find the factorial of any number.
7. Write a PL/SQL program to display sum of even numbers and sum of odd numbers in the given range.
8. Write a PL/SQL program to check the given number is palindrome or not.
9. The HRD manager has decide to raise the employee salary by 15% write a PL/SQL block to accept the employee number and update the salary of that employee. Display appropriate message based on the existence of the record in Emp table.
10. Write a PL/SQL program to display to 10 rows in Emp table based on their job and salary.
11. Write a PL/SQL program to raise the employee salary by 10% for department number 30 people and also maintain the raised details in the raise table.
12. Write a procedure to update the salary of Employee, who are not getting commission by 10%.
13. Write a PL/SQL procedure to prepare an electricity bill by using following table.

Table used: Elect

Name	Null?	Type
MNNO	NOT NULL	NUMBER(3)
CNAME		VARCHAR2(20)
CUR_READ		NUMBER(5)
PREV_READ		NUMBER(5)
NO_UNITS		NUMBER(5)
AMOUNT		NUMBER(8,2)
SER_TAX		NUMBER(8,2)
NET_AMT		NUMBER(9,2)

14. Write a PL/SQL program to prepare an telephone bill by using following table and print the monthly bills for each customer.

Table used: Phone		
Name	Null?	Type
TEL_NO	NOT NULL	NUMBER(6)
CNAME		VARCHAR2(20)
CITY		VARCHAR2(10)
PR_READ		NUMBER(5)
CUR_READ		NUMBER(5)
NET_AMT		NUMBER(5)
TOT-AMT		NUMBER(8,2)

15. Write a PL/SQL program to raise the employee salary by 10 %, who are completed ther 25 years of service and store the details at appropriate tables (Define the Retair_ Emp_Table) .
16. Write a PL/SQL program to evaluate the grade of a student with following conditions:
 For pass: all marks > 40
 For I class: Total % > 59
 For II Class: Total % between >40 and < 60
 For III class: total % = 40
 And also maintain the details in abstract table.

1. Table Std		
Name	Null?	Type
NO	NOT NULL	NUMBER
NAME		VARCHAR2(10)
INTNO		NUMBER
CLASS	NOT NULL	VARCHAR2(10)
M1		NUMBER
M2		NUMBER
M3		NUMBER
M4		NUMBER
M5		NUMBER

2. Table Abstract		
Name	Null?	Type
STDNO		NUMBER
STDNAME		VARCHAR2(10)
CLASS		VARCHAR2(10)
MONTH		VARCHAR2(10)
INTNO (INTEGER NUMBER)		NUMBER
TOT		NUMBER
GRADE		VARCHAR2(10)
PERCENT		NUMBER
DAT_ENTER		DATE

A.G & S.G Siddhartha Degree College of Arts & Science, Vuyuru – 521165.
(An Autonomous College in the jurisdiction of Krishna University)
M.Sc., (Computer Science) Programme - III Semester

Course	CRYPTOGRAPHY A& NETWORK SECURITY		
Course Code	20CS3T1	Course Delivery Method	Class Room / Blended Mode
Credits	4	CIA Marks	30
No. of Lecture Hours / Week	4	Semester End Exam Marks	70
Total Number of Lecture Hours	60	Total Marks	100
Year of Introduction : 2018	Year of Offering: 2021	Year of Revision: 2021	Percentage of Revision: 10

Course Objective: To understand and gain knowledge on Computer & Network Security, Number Theory, Classical Encryption Techniques, Advanced Encryption Standard and Random Bit Generation and Stream Ciphers, Number Theory, Public Key Cryptography and RSA, Other Public-Key Crypto Systems and Message Authentication Codes, Digital Signatures, Key Management and Distribution and User Authentication, Transport Level Security, Electronic Mail Security and IP Security and Intruders and Firewalls.

Course Outcomes: On successful completion of this course, the students will be able to:

CO1 : Understand Computer & Network Security Concepts, Classical Encryption Techniques and Advanced Encryption Standard.

CO2 : Gain knowledge on Number Theory, Public Key Cryptography and RSA, Other Public-Key Crypto Systems and Message Authentication Codes.

CO3 : Know Digital Signatures, Key Management and Distribution and User Authentication.

CO4 : Understand Transport Level Security, Electronic Mail Security and IP Security.

CO5 : Gain knowledge about Intruders and Firewalls.

Syllabus

Unit	Learning Units	Lecture Hours
I	<p>Computer & Network Security Concepts: Computer Security Concepts, The OSI Security Architecture, Security Attacks, Security Services, Security Mechanisms, A Model for Network Security.</p> <p>Classical Encryption Techniques: Symmetric Cipher Model, Substitution Techniques, Transposition Techniques, Rotor Machines, Steganography</p> <p>Advanced Encryption Standard: Block cipher principles, the strength of DES, Differential and linear cryptanalysis, Block cipher design principles.</p> <p>Confidentiality using symmetric Encryption: Placement of encryption function Traffic Confidentiality, key distribution, random number generator</p>	12
II	<p>Public key cryptography and RSA: Principles of public key crypto systems, The RSA algorithm</p> <p>Key Management: Other public key cryptosystems: key management, diffie-Hellman key exchange.</p> <p>Message authentication and hash functions: Authentication requirements, Authentication functions, message authentication codes, Hash functions, security of hash functions and MACs</p>	12
III	<p>Digital Signatures and Authentication protocols: Digital Signatures, Authentication protocols, Digital signatures standard.</p> <p>Authentication Applications: Kerberos, X.509 authentication service</p>	12
IV	<p>Email Security: Pretty good privacy, S/MIME</p>	12

	<p>IP Security: IP security overview, IP security architecture, Authentication header, Encapsulating security payload, combining security associations, key management.</p> <p>Web security: Web Security considerations, secure socket layer and transport layer security, secure electronic transaction.</p>	
V	<p>Intruders: Intruders, Intrusion Detection, Password Management.</p> <p>Malicious Software: Viruses and related threads, virus counter measures , Distributed denial of service attacks</p> <p>Firewalls: The Need for Firewalls, Firewall Characteristics and Access Policy, Types of Firewalls.</p>	12

Prescribed Text Book			
	Author	Title	Publisher
1	William Stallings	Cryptography and Network Security	Pearson, Seventh Edition, 2017

Reference Text Book			
	Author	Title	Publisher
1	William Stallings	Cryptography and Network Security	Pearson, Sixth Edition, 2014
2	William Stallings	Network Security Essentials- Applications and Standards	Pearson Education (2007), Third Edition.
3	Chris McNab	Network Security Assessment	OReilly (2007), 2 nd Edition
4	Jon Erickson	Hacking-The Art of Exploitation	Press (2006),SPD
5	Neal Krawety	Introduction to Network Security	Thomson (2007).
6	Ankit Fadia	Network Security-AHackers Perspective	Macmillan (2008)
7	Behrouz A Forouzan, Debdeep Mukhopadhyay	Cryptography and Network Security	MCGraw-Hill, Indian Special Edition, Third Edition, 2015

Course has focus on : Employability

Websites of Interest :

1. https://www.pearsonhighered.com/assets/hip/us/hip_us_pearsonhighered/preface/0132775069.pdf
2. <http://faculty.mu.edu.sa/public/uploads/1360993259.0858Cryptography%20and%20Network%20Security%20Principles%20and%20Practice,%205th%20Edition.pd>

Co-curricular Activities : Programming Contests, Hackathons & Quiz.

A.G & S.G Siddhartha Degree College of Arts & Science, Vuyyuru – 521165.
(An Autonomous College in the jurisdiction of Krishna University)
M.Sc., (Computer Science) Programme - III Semester
Course Code: 21CS3T1 Title: CRYPTOGRAPHY & NETWORK SECURITY
(w.e.f admitted batch 2021-22)

Time: 3 Hours

Answer ALL questions

Max. Marks: 70
(10×2 = 20 Marks)

- 1) a) What is Caesar Cipher?
- b) What is Steganography?
- c) What is Key management?
- d) What is Hash functions?
- e) What is the Digital signatures?
- f) What is Kerberos?
- g) State any two Protocols of Transport Layer Security.
- h) What is Pretty Good Privacy?
- i) What is Firewall?
- j) State any two Intrusion Detection Techniques.

Answer Five Questions Choosing One Question from Each Unit.

All Questions Carry Equal Marks.

(5×10 = 50 Marks)

UNIT- I

- 2) a) Explain various Security Attacks and Security Services. 10 Marks
- (or)
- b) Explain AES Encryption and Decryption Process. 10 Marks

UNIT- II

- 3) a) Illustrate Diffie-Hellman Key Exchange. 10 Marks
- (or)
- b) Explain about hash functions and MAC. 10 Marks

UNIT-III

- 4) a) Explain Digital Signature in detail . 10 Marks
- (or)
- b) Explain about X.509 authentication service (BTL5) 10 Marks

UNIT-IV

- 5) a) Explain Confidentiality and Authentication in S/MIME. 10 Marks
- (or)
- b) Illustrate Overview of IP Security. 10 Marks

UNIT-V

- 6) a) Discuss what are the problems that may intruder create and explain how to overcome those problem?
10 Marks
- (or)
- b) Discuss Various Types of Firewalls. 10 Marks

A.G & S.G Siddhartha Degree College of Arts & Science, Vuyyuru – 521165.
(An Autonomous College in the jurisdiction of Krishna University)
M.Sc., (Computer Science) Programme - III Semester

Course	DESIGN & ANALYSIS OF ALGORITHMS		
Course Code	20CS3T2	Course Delivery Method	Class Room / Blended Mode
Credits	4	CIA Marks	30
No. of Lecture Hours / Week	4	Semester End Exam Marks	70
Total Number of Lecture Hours	60	Total Marks	100
Year of Introduction :2018	Year of Offering:2021	Year of Revision:2006	Percentage of Revision:10%

Course Objective: The objective of this course is to develop proficiency in Problem Solving and Programming, To Perform Analysis of various Algorithms in regard to Time and Space Complexity, Gain good understanding of Applications of Data Structures, To develop a base for Advanced Study in Computer Science, To apply Design Techniques to solve different types of problems as per their Complexity and Develop ability to segregate NP-Hard and NP-Complete problems.

Course Outcomes: On successful completion of this course, the students will be able to:

CO1 : Understand Basic Ideas about Analysis of Algorithms and the Concept of Data Structures.

CO2 : Know Divide and Conquer ,Greedy Methods and Solving Various Problems by applying them.

CO3 : Apply Dynamic Programming Method and Basic Traversal and Search Techniques to solve various Problems.

CO4 : Understand Backtracking and Branch and Bound Techniques to Design Algorithms.

CO5 : Categorize NP-Hard and NP-Complete Problems.

Syllabus

Unit	Learning Units	Lecture Hours
I	<p>Introduction: What is Algorithm, Algorithm Specification Pseudo code Conventions, Recursive Algorithms, Performance Analysis: Space Complexity Time Complexity, Asymptotic Notation, Performance Measurement, Randomized Algorithms: Basics of Probability Theory, Randomized Algorithms Identifying the Repeated Element, Primality Testing: Advantages and Disadvantages.</p> <p>Elementary Data Structures: Stacks and Queues, Trees: Terminology, Binary Trees, Dictionaries: Binary Search Trees, Priority Queues, Heaps , Heapsort , Sets and Disjoint Set Union: Introduction-Union and Find Operations, Graphs: Introduction, Definitions, Graph Representations.</p>	10
II	<p>Divide-and-Conquer: General Method, Defective Chess Board, Binary Search, Finding Maximum and Minimum, Merge Sort, Quick Sort, Selection Problem, Strassen's Matrix Multiplication, Convex Hull: Some Geometric Primitives, The Quick Hull Algorithm, Graham's Scan, An O(nlogn) Divide and Conquer Algorithm.</p> <p>The Greedy Method: The General Method, Container Loading, Knapsack Problem, Tree Vertex Splitting, Job Sequencing with Deadlines, Minimum Cost Spanning Trees: Prim's Algorithm, Kruskal's Algorithm, Optimal Storage on Tapes, Optimal Merge Patterns, Single Source Shortest Paths.</p>	14

III	<p>Dynamic Programming: The General Method, Multi Stage Graphs, All Pairs Shortest Paths, Single Source Shortest Paths, Optimal Binary Search Trees, String Editing -0/1 Knapsack, Reliability Design, The Traveling Sales Person Problem, Flow Shop Scheduling.</p> <p>Basic Traversal and Search Techniques: Techniques for Binary Trees, Techniques for Graphs: Breadth First Search and Traversal-Depth First Search, Connected Components and Spanning Trees, Bi-Connected Components and DFS.</p>	17
IV	<p>Backtracking: The General Method, The 8-Queens Problem, Sum of Subsets, Graph Coloring, Hamiltonian Cycles, Knapsack Problem.</p> <p>Branch and Bound : The Method: Least Cost Search, The 15 Puzzle Control Abstractions for LC Search, Bounding, FIFO Branch and Bound , LC Branch and Bound, 0/1 Knapsack Problem, LC Branch and Bound Solution, FIFO Branch and Bound Solution, Traveling Sales person.</p>	11
V	<p>NP-Hard and NP-Complete Problems: Basic Concepts: Non Deterministic Algorithms, The Classes NP Hard and NP Complex, Cook's Theorem, NP Hard Graph Problems, Clique Decision Problem, Node Cover Decision Problem Chromatic Number Decision Problem, Directed Hamiltonian Cycle, Traveling Sales Person Decision Problem, AND/OR Graph Decision Problem, NP-Hard Scheduling Problems, Scheduling Identical Processors, Flow Shop Scheduling, Job Scheduling.</p>	8

Prescribed Text Book

S.No	Author	Title	Publisher
1	Sartaj Sahni	Fundamentals of Computer Algorithms	Second Edition, Universities Press (2008)

Reference Text Books

S.No.	Author	Title	Publisher
1	Anany Levitin	Introduction to the Design & Analysis of	Second Edition, Pearson
2	I.Chandra Mohan	Design and Analysis of Algorithms	PHI
3	Prabhakar Gupta, Vineet Agrawal	Design and Analysis of Algorithms	PHI
4	Parag Himanshu, Dave	Design and Analysis of Algorithms	Pearson Education (2008)

Course Focus: Foundation / Skill Development.

Reference Websites :

- <https://epgp.inflibnet.ac.in/Home>
- <https://ocw.mit.edu/courses/electrical-engineering-and-computer-science/6-046j-design-and-analysis-of-algorithms-spring-2015/lecture-notes/>
- https://www.cukashmir.ac.in/cukashmir/User_Files/imagefile/DIT/StudyMaterial/DAA/DAA_UNIT-I_6th-Sem_StudyMaterial.pdf

A.G & S.G Siddhartha Degree College of Arts & Science, Vuyyuru – 521165.

(An Autonomous College in the jurisdiction of Krishna University)

M.Sc.(Computer Science) Programme - III Semester

Course Code: 21CS3T2 Title: DESIGN AND ANALYSIS OF ALGORITHMS

(w.e.f admitted batch 2021-22)

Time: 3 Hours

Answer ALL questions

Max. Marks: 70

(10×2 = 20 Marks)

1. a) Define Algorithm.
- b) What is a priority queue?
- c) Define Convex Hull.
- d) What is tree vertex splitting?
- e) What is String Editing ?
- f) Differentiate DFS and BFS.
- g) What is Graph colouring?
- h) What is LC and FIFO Branch and Bound?
- i) Compare NP hard and NP complete classes.
- j) What is flow shop scheduling in NP Hard Scheduling problems?

Answer Five Questions Choosing One Question from Each Unit.

All Questions Carry Equal Marks.

(5×10 = 50 Marks)

UNIT – I

2. A) Explain Asymptotic Notations regarding time and space complexities of an algorithm.
(or)
B) Explain in detail about Heap Sort Technique with an example.

UNIT – II

3. A) What is Divide and Conquer approach? Apply it on Quick Sort with an example.
(or)
B) What is Greedy method? Explain Kruskal's Algorithm to find minimum cost spanning tree with an example.

UNIT – III

4. A) Explain the application of Dynamic Programming on Travelling Salesman Problem.
(or)
B) Explain the procedure to obtain Optimal Binary Search Tree by applying Dynamic Programming approach.

UNIT – IV

5. A) What is 0/1-Knapsack Problem ? Solve it using Branch and Bound technique.
(or)
B) Explain the Sum of Subsets Problem. How can it be solved using Back Tracking Technique?

UNIT – V

6. A) Write Cook's theorem. Briefly explain Cook's theorem.
(or)
B) Discuss various NP Hard Graph Problems.

A.G & S.G Siddhartha Degree College of Arts & Science, Vuyuru – 521165.
(An Autonomous College in the jurisdiction of Krishna University)
M.Sc., (Computer Science) Programme - III Semester

Course	WEB TECHNOLOGIES		
Course Code	20CS3T3	Course Delivery Method	Class Room / Blended Mode
Credits	4	CIA Marks	30
No. of Lecture Hours / Week	4	Semester End Exam Marks	70
Total Number of Lecture Hours	60	Total Marks	100
Year of Introduction :2018	Year of Offering:2021	Year of Revision:2021	Percentage of Revision:10

Course Objective:

Understand the principles of creating an effective web page, including an in-depth consideration of information architecture. Become familiar with graphic design principles that relate to web design and learn how to implement theories into practice. Develop skills in analyzing the usability of a web site. Understand how to plan and conduct user research related to web usability. Learn the language of the web: HTML and CSS. Develop basic programming skills using Javascript and jQuery. Be able to embed social media content into web pages.

Course Outcomes:

CO1: Build functional Web Applications HTML.

CO2: Understand the concept of JAVA SCRIPTS

CO3: Understand the concept of DOM and CSS selectors .

CO4: : Create Dynamic Web Pages where in Client Interaction is facilitated using Advanced Server Technology like JSP.

CO5: Understand how to create web pages using PHP and identify the difference between the HTML, PHP. Integrate Offline Data Storage, Background Processes and APIs using Database Connectivity

Syllabus

Unit	Learning Units	Lecture Hours
I	Introduction: Evolution of Internet and World Wide Web, Web Basics, Multitier Application Architecture, Client-Side Scripting versus Server-Side Scripting, Object Technology HTML5: Introduction, Editing HTML5, First HTML5 Example, W3C HTML5 Validation Service, Headings, Linking, Images, Special Characters and Horizontal Rules, Lists, Tables, Forms, Internal Linking, meta Elements, HTML5 Form input Types, input and datalist Elements and autocomplete Attribute, Page-Structure Elements.	10

II	CSS: Introduction, Inline Styles, Embedded Style Sheets, Conflicting Styles, Linking External Style, Positioning Elements, Backgrounds, Element Dimensions, Box Model and Text Flow, Media Types, Building a CSS Drop-Down Menu, User Style Sheets, Text Shadows, Rounded Corners, Color, Box Shadows, Image Borders, Animation-Selectors. JavaScript: Introduction to Scripting, Control Statements I, Control Statements II, Functions, Arrays, Objects, Document Object Model, Event Handling.	14
III	JQuery Basics: String, Numbers, Boolean, Objects, Arrays, Functions, Arguments, Scope, Built-in Functions. jQuery-Selectors: CSS Element Selector, CSS Element ID Selector, CSS Element Class Selector, CSS Universal Selector, Multiple Elements E, F, G Selector, Callback Functions. jQuery-DOM Attributes: Get Attribute Value, Set Attribute Value. jQuery – DOM Traversing : Find Elements by index, Filtering out Elements, Locating Descendent Elements, JQuery DOM Traversing Methods.	17
IV	JQuery CSS Methods: Apply CSS Properties, Apply Multiple CSS Properties, Setting Element Width & Height, JQuery CSS Methods. jQuery – DOM Manipulation Methods: Content Manipulation, DOM Element Replacement, Removing DOM Elements, Inserting DOM elements, DOM Manipulation Methods. jQuery – Event Handling: Binding event handlers, Removing event handlers, Event Types, The Event Object, The Event Attributes. jQuery – Effects: JQuery Effect Methods, jQuery Hide and Show, jQuery Toggle, jQuery Slide – slideDown, SlideUP, SlideToggle, jQuery Fade- fadeIn – fadeout, faceTo, jQuery Custom Animations.	11
V	Databases: SQL, MYSQL. PHP: Introduction, Simple PHP Program, Converting Between Data Types, Arithmetic Operators, Initializing and Manipulating Arrays, String Comparisons, String Processing with Regular Expressions, Form Processing and Business Logic, Reading from a Database, Using Cookies, Dynamic Content.	8

Text Books			
	Author	Title	Publisher
1	Harvey M.Deitel and Paul J.Deitel	Internet and World Wide Web How To Program, 5e	Prentice Hall; 4 th edition
2	Robert W Sebesta	Programming with World Wide Web	Pearson Education; 4 th edition.
3	Jon Duckett	JavaScript & jQuery	Wiley

Reference Books			
	Author	Title	Publisher
1	Chris Bates	Web Programming Building Internet Application, Second Edition	Wiley (2007)
2	Uttam Kumar Roy	Web Technologies	Oxford University Press

Websites of Interest:

1. <https://www.w3schools.com/html/default.asp>
2. <https://www.udemy.com/course/wix-master-course-make-a-website-in-1-day-with-wix>

Course Focus: Foundation / Employability / Skill Development.

Time: 3 Hours

Max. Marks: 70

Answer ALL questions

(10×2 = 20 Marks)

1. a) What is WWW?
- b) Explain Meta Elements.
- c) Explain embedded style sheet with an example.
- d) What is Event Handling?
- e) List out built in functions in jQuery.
- f) Define Array. How to declare arrays in jQuery?
- g) How to set element width and height in JQuery?
- h) Explain Arithmetic operations in PHP.
- i) What are DDL Statements?
- j) Define cookies.

Answer Five Questions Choosing One Question from Each Unit.

All Questions Carry Equal Marks.

(5×10 = 50 Marks)

UNIT – I

2. A) How do you add Tables and Images to HTML page?
(or)
B) Distinguish Client side scripting versus Server side scripting.

UNIT – II

3. A) Write short notes on user style sheets.
(or)
B) Explain control statements in java script with example.

UNIT – III

4. A) What are jQuery Selector? Give some examples.
(or)
B) Explain jQuery DOM attributes with an example.

UNIT – IV

5. A) Explain jQuery CSS methods with an example
(or)
B) What are the effect methods used in jQuery?

UNIT – V

6. A) Differentiate between SQL and MYSQL databases
(or)
B) How to read data from a database in PHP? Explain with an example.

A.G & S.G Siddhartha Degree College of Arts & Science, Vuyyuru – 521165.
(An Autonomous College in the jurisdiction of Krishna University)
M.Sc., (Computer Science) Programme - III Semester

Course	DATA MINING TECHNIQUES		
Course Code	20CS3T4	Course Delivery Method	Class Room / Blended Mode
Credits	4	CIA Marks	30
No. of Lecture Hours / Week	4	Semester End Exam Marks	70
Total Number of Lecture Hours	60	Total Marks	100
Year of Introduction :2018	Year of Offering:2021	Year of Revision:2020	Percentage of Revision:10%

Course Objective:

To understand and gain knowledge on Basic Concepts, Applications, Techniques of Data Mining, Data Warehouse Architecture and its Components, Schemas, Different OLAP Operations, Characterize The Kinds of Patterns that can be discovered by Association Rule Mining, Data Classification and Prediction Techniques, Identify the Similarities among the data Using Clustering Algorithms and Outlier Analysis.

Course Outcomes: On successful completion of this course, the students will be able to

CO1: Understand the Basics of Data Mining and Data Pre-Processing Techniques.

CO2: Aware of constructing the Data Warehouse, OLAP and relevant Data Model Concepts.

CO3: Understand the Frequent Itemset Mining Methods and Different Levels in Association Rules.

CO4: Understand the Basic Concepts in Classification and Advanced Classification Methods by implementing Various Algorithms.

CO5: Find the similarities among the data using Clustering Algorithms and Outlier Analysis.

Syllabus

Unit	Learning Units	Lecture Hours
I	Warehouse: What is it, Who need it, and Why? Things to consider, Managing the Data Warehouse, Getting ready for your project, Picking a target and moving forward, Project management benefits, The Scope statement, Work breakdown structure, Project estimating, Scope creep & tracking project's progress.	12
II	Data Warehouse Design Methodology: The preferred Architecture, Alternate warehouse architectures, Data Marts and Star Schema Design, Fundamentals of ETL Architecture, Partitioning Data.	12
III	Data Mining: Introduction, Data mining on What kind of data, Data mining functionalities classification of Data mining systems, Major issues in Data mining. Mining Association rules in large databases: Association rule mining, Mining	12

	single-Dimensional Boolean association rules from Transactional databases, Mining multi-Dimensional Association rules from relational Databases and Data Warehouses.	
IV	Classification and Prediction: Introduction to classification by decision tree induction, Bayesian Classification, Other classification methods, classification by back propagation, Prediction, classifier accuracy.	12
V	Cluster Analysis : Introduction, types of data in cluster analysis, a categorization of major clustering methods, partitioning methods, hierarchical methods. Density based methods: DBSCAN, Grid-based method: STING, Model based clustering method : Statistical Approach.	12

Text Books:

	Author	Title	Publisher
1	Michael Corey, Michael Abbey, Ian Abramson, Ben Taub	Oracle 8i Data Warehousing	TMH(Unit- I & II)
2	Jiawei Han MichelineKamber	Data mining & Techniques	Morgan Kaufmann Publishers(Unit-III to V)

Reference Books:

1	S.N.Sivanandam, S.Sumathi	Data Mining-Concepts, Tasks and Techniques	Thomson(2006)
2	Ralph Kimball	The Data Warehousing Toolkit	Wiley
3	Margaret H.Dunham	Data Mining-Introduction and Advanced Topics	Pearson Education
4	D.Hand, H.Mannila and P.Smyth	Principles of Data Mining	PHI(2001)

Websites of Interest:

1. [www- db.stanford.edu ^ullman/mining/mining.html](http://www-db.stanford.edu/~ullman/mining/mining.html) : Data mining lecture notes.
2. ocw.mit.edu/ocwweb/slon-School-of-management/15-062Data-Mining Spring2003/course

Course Focus: Foundation / Employability / Skill Development.

A.G & S.G Siddhartha Degree College of Arts & Science, Vuyyuru – 521165.
(An Autonomous College in the jurisdiction of Krishna University)
M.Sc., (Computer Science) Programme - III Semester
Course Code: 21CS3T4 Title: DATA MINING TECHNIQUES
(w.e.f admitted batch 2021-22)

Time: 3 Hours

Max. Marks: 70

Answer ALL questions

(10×2 = 20 Marks)

1. Define Data Warehouse.
2. what is Data Mart.
3. What is snowflake scheme?
4. Define partitioning data.
5. Define Data Mining.
6. Define Classification and Prediction.
7. What are the major issues in Data mining.
8. Define Linear Regression.
9. Define Outlier Analysis.
10. what is clustering?

Answer Five Questions Choosing One Question from Each Unit.

All Questions Carry Equal Marks.

(5×10 = 50 Marks)

Unit-1

- 11 a) Discuss about Data Warehouse on user's perspective and developer's perspective .

(or)

- b) Explain about the Work Breakdown structure.

Unit-2

- 12 a) Explain about Data Warehouse Architecture.

(or)

- b) Discuss about the ETL design in detail.

Unit-3

- 13 a) Explain about data mining functionalities.

(or)

- b) Explain about the FP Growth algorithm with example.

Unit-4

- 14 a) Briefly discuss about classification by back propagation.

(or)

- b) Briefly discuss about Bayesian Classification.

Unit-5

- 15 a) Explain about the partitioning clustering .

(or)

- b). Discuss about DBSCAN & STING

A.G & S.G Siddhartha Degree College of Arts & Science, Vuyyuru – 521165.
(An Autonomous College in the jurisdiction of Krishna University)
M.Sc., (Computer Science) Programme - III Semester

Course	WEB TECHNOLOGIES LAB		
Course Code	20CS3L1	Course Delivery Method	Class Room / Blended Mode
Credits	4	CIA Marks	30
No. of Lecture Hours / Week	8	Semester End Exam Marks	70
Total Number of Lecture Hours	90	Total Marks	100
Year of Introduction :2018	Year of Offering:2021	Year of Revision:2021	Percentage of Revision: 10%

Course Objective: Able to build functional Web Applications using HTML, Able to use JavaScript and DHTML for Web Designing, Able to code using XML and PHP for Integrating with Web Pages, Create Dynamic Web Pages where in client interaction is facilitated using advanced server technology like JSP and Web Pages with Database Connectivity using PHP.

Course Outcomes: On successful completion of the course student will be able to:

CO1: Build functional Web Applications HTML.

CO2: Incorporates Multimedia Capabilities and Web Page Designs using Cascading Style Sheets.

CO3: Code Client Server Interaction Programs using Java Based Server Technology named Servlets.

CO4: Create Dynamic Web Pages where in Client Interaction is facilitated using Advanced Server Technology like JSP.

CO5: Integrate Offline Data Storage, Background Processes and APIs using Database Connectivity and ASP.

Lab list

Course Details

HTML:

1. Develop HTML code to provide intra document linking.
2. Develop HTML code to provide inter document linking.
3. Develop a program to implement the three types of lists.
4. Create a HTML page using frames.
5. Develop a program to embed college picture into your web page and develop a short note on your college using paragraph tag.
6. Illustrate a suitable example; depict how we can align text using a table tag as follows.

II M.C.A	Pass percenetage=95%
	Fail percentage=5%
III M.C.A	Pass percenetage=97%
	Fail percentage=3%

7. Develop a program to create the time table as follows:

	1	2	3		4	5	6
MON	<-----WEB LAB----->				SE	WEB	PPL
TUE	UML	CRY	SE	B R E A K	<-----VB LAB----->		
WED	WEB	SE	UML		CRY	PPL	
THU	CRY	WEB	PPL		<-----WEB LAB----->		
FRI	<-----VB LAB----->				PPL	WEB	UML
SAT	SE	CRY	UML		<-----SEMINARS----->		

8. Create a Registration form that interacts with the user. Collect login name, password, date of birth, sex, address, qualification and display a “Thank you for registering” message when the user submits the form.

Login name:
Enter Password:
Reenter Password:
Birthdate:
Sex: Male Female
Enter Address
Enter qualification

Java Script:

9. Develop a script to compare two strings using String object.
10. Develop a script to generate random numbers within 1 to 10 and display the numbers in a table.
11. Develop a Java Script to update the information into the array, in the “onClick” event of the button “Update”.
12. Create a web page for a shopping mall that allows the user to tick off his purchases and obtain the bill with the total being added up simultaneously.

Item details	Price of item	Click here to select
	8399	<input type="checkbox"/>
	5000	<input checked="" type="checkbox"/>
	450	<input checked="" type="checkbox"/>
	399	<input type="checkbox"/>
YOUR TOTAL BILL IS 5450		

13. Develop a script to find the duplicate elements of an array.
14. Develop a script which generates a different greeting each time the script is executed.
15. Develop a JavaScript to check the number is Armstrong number or not by getting the number from textbox and the result is displayed in a alert dialog box.
16. Develop a java script code that accepts user name and password from user, Check their correctness and display appropriate alert messages.

DHTML:

17. Create an inline style sheet. Illustrate the use of an embedded style sheet.
18. Create an external style sheet to illustrate the “Font” elements.
19. Develop a program to switch on and off light using onClick event.
20. Illustrate different types of filters (at least six) on a sample text.
21. Develop a program to illustrate tabular data control for data binding.

XML:

22. Create a small XML file designed to contain information about student performance on a module. Each student has a name, a roll number, a subject mark and an exam mark.
23. Create a internal DTD file.
24. Create an external DTD file.
25. Create a XSLT style sheet to display the student data as an HTML table.

PHP:

26. Illustrate PHP declarations and expressions to find factorial of a given number using.
27. Develop a PHP program that interacts with the user .Collect first name last name and date of birth and displays that information back to the user.
28. Develop a PHP program to connect MySQL Database.

JSP:

29. Develop a program to implement JSP directives.
30. Develop a JSP program for session tracking.

Prescribed Textbook			
	Author	Title	Publisher
1	N.P.Gopalan, J.Akilandeswari	Web Technologies-A Developer’s Perspective	PHI(2008)
2	Harvey M. Deitel and Paul I. Deitel	Internet and World Wide Web How To Program, 5e	Prentice Hall; 4th edition

Course Focus: Employability

Websites of Interest:

1. <https://www.w3schools.com>
2. <https://www.edx.org/learn/web-development>
3. <https://www.codecademy.com/learn/paths/web-development>

A.G & S.G Siddhartha Degree College of Arts & Science, Vuyyuru – 521165.
(An Autonomous College in the jurisdiction of Krishna University)
M.Sc., (Computer Science) Programme - III Semester

Course	DATA MINING LAB		
Course Code	20CS3L2	Course Delivery Method	Class Room / Blended Mode
Credits	4	CIA Marks	30
No. of Lecture Hours / Week	8	Semester End Exam Marks	70
Total Number of Lecture Hours	90	Total Marks	100
Year of Introduction : 2018	Year of Offering : 2021	Year of Revision : 2020	Percentage of Revision: 10%

Course Objective:

The main objective of this lab is to impart the knowledge on How to implement Data Mining Algorithms using Various Tools and How to characterize the kinds of Patterns that can be discovered by Association Rule Mining, Classification, Clustering, Identifying Outliers and Emphasize Hands-on Experience working with all Real Time Data Sets.

Course Outcomes: On successful completion of this course, the students will be able to

CO1: Understand the Various Kinds of Tools.

CO2: Apply Mining Techniques for Realistic Data.

CO3: Understand the Basic Concepts in R and Weka.

CO4: Understand how to import and export CSV Files and Package installation in R.

CO5: Develop and visualization of Data Mining Algorithms in R.

Using R Programming:

1. How to import data into R from text and excel files using read.table() and read.csv functions. .
2. Create Association Rules using Aprior Algorithm in R.
3. Construct Multilayer Perceptron or Neural Network using R.
4. Apply Time Series Analysis using R.
5. Apply Time Series Forecasting using R.
6. Apply Time Series Decomposition using R.
7. Create K-Means Clustering Algorithm using R.
8. Construct Decision Tree in R using package party.
9. Create Hierarchical Clustering using R.
10. Create Hierarchical Clustering with Euclidean Distance using R
11. Examine K-Medoids clustering using R.
12. Detecting and Removing outliers using R.
13. Construct Density Based Clustering using R.
14. Illustrate Linear Regression using R.
15. Illustrate Multiple Regression using R.
16. Illustrate Logistic Regression using R.
17. Construct Outlier Detection by Clustering using R.
18. Detecting and Removing Missing values in R.
19. Create different kinds of Charts using Sample Data Sets in R.
20. Create Word Cloud using R.

Websites of Interest :

1. <https://www.rdocumentation.org/packages/stats/versions/3.6.2>
2. <http://www.r-bloggers.com/>

Course Focus: Foundation / Employability / Skill Development.

APPENDIX - III
OPEN ELECTIVES OFFERED BY COMPUTER SCIENCE DEPARTMENT

A.G & S.G Siddhartha Degree College of Arts & Science, Vuyyuru – 521165.
(An Autonomous College in the jurisdiction of Krishna University)
M.Sc., (Computer Science) Programme - III Semester

Course	VISUAL ANALYTICS FOR EXECUTIVES		
Course Code	21CS3OEL1	Course Delivery Method	Face-to-face/Blended Mode
Course Category	Open elective	Lecture-Tutorial-Practical	2-0-4
Credits	4	CIA Marks	30
No. of Lecture Hours / Week	6	Semester End Exam Marks	70
Total Number of Lecture Hours	60	Total Marks	100
Year of Introduction : 2021	Year of Offering: 2021	Year of Revision: 2021	Percentage of Revision: Nil

Course Objectives : This Course focuses to know the Importance of Visualization in the world of Data Analytics and Prediction, To handle Data Sources in Tableau, To get familiarized about creating visualization using different Types of Charts, To gain knowledge about using Maps in Tableau, To gain knowledge about Analysis, To design Interactive Dash Boards.

Course Outcomes : At the end of this course, students should be able to:

CO1 : Able to know the importance of Visualization and connect Different Data Sources in Tableau.

CO2 : Able to create Charts in Tableau.

CO3 : Able to implement Aggregate Functions, Calculated Fields, Table Calculations and Level of Detail Calculations.

CO4 : Able to implement Maps and Advance Analytic.

CO5 : Able to create Interactive Dash Boards.

Syllabus		
Unit	Learning Units	Lecture Hours
I	Introduction and Getting Started with Tableau: The Advantages of a Modern Analytics Platform, The Tableau Application Suite, Installing Tableau Desktop Data Preparation, The Sample Dataset, The Tableau Workspace, Working With Measures and Dimensions. Working With Marks, Saving, Opening, And Sharing Your Workbooks. Adding Data Sources in Tableau: Setting up a Data Connector, Selecting Data Tables, Joins, Unions, Data Extracts and Live Connections, Editing The Model's Metadata, Data Types, Adding Hierarchies, Calculated Fields and Table, Calculations, Data Collection.	12
II	Creating Data Visualizations: Chart Types, Ready, Set, Show Me, Bar Charts, Legends, Filters and Hierarchies,, Line Charts, Highlight Tables, Heatmaps, Bullet Charts, Cumulative Sums With Waterfall Charts, Reflection, The Anatomy of A Tableau Visualization.	12
III	Aggregate Functions, Calculated Fields, and Parameters: Aggregate Functions, Calculated Fields, Aggregations in Calculated Fields, Text Operators, Date Fields, Logical	12

	Functions In Calculated Fields, Parameters, Searching Text Fields. Table Calculations and Level of Detail Calculations: Different Types of Calculations, Quick Table Calculations, Customized Table Calculations, Level of Detail Expressions.	
IV	Maps: Symbol Maps, Filled Maps, Density Maps, Map Layers, Maps With Pie Charts, Viz in Tooltip. Reflection: The Anatomy of a Tableau Map, Alternative Map Services, Mapbox Maps, Spatial Data. Advanced Analytics: Trends, Forecasts, Clusters and Other Statistical Tools, Overview of The Tableau Analytics Pane, Constant, Average, Reference Lines, Trend Lines, Forecasts, Cluster Analysis.	12
V	Interactive Dashboards: Preliminary Considerations, Creating a New Dashboard, The Dashboard Pane, Placing Charts on the Dashboard, Dashboard Titles, Navigation Buttons, Dashboard Actions.	12

Course has focus on : Employability

Websites of Interest :

1. Visual Analytics in Tableau | <https://www.youtube.com/watch?v=gEKQ3kigJsM>
2. Tableau Training for Beginners | Edureka <https://www.youtube.com/watch?v=aHaOlvR00So>
3. Tableau Training for Beginners | Simplilearn <https://www.youtube.com/watch?v=Wh4sCCZjOwo>
4. Tableau Full Course| <https://youtu.be/KA0QHWm0nWo>

Co-curricular Activities : Programming Contests, workshops & Quiz.

Lab List:

1. Tableau installation.
2. Tableau Introduction /Exploring Tableau.
3. Creating New Workbooks Opening Existing Workbooks in Tableau
4. Data Collection from various sources web/text/csv/JSON
5. Implementing joins and Unions
6. Creating Bar Chart.
7. Creating Pie Chart.
8. Creating Dual Axis Chart.
9. Creating Shared Axis.
10. Creating Cross Tab.
11. Creating Word Cloud.
12. Creating Scatter Plot.
13. Creating Bubble Chart.
14. Implementing Data Blending.
15. Implementing Word Cloud.
16. Implementing Aggregate Functions, Calculated Fields.
17. Implementing Table Calculations and Level of Detail Calculations.
18. Creating Maps.
19. Implementing Trend lines and analytics in Tableau.
20. Creating a Dash Board.

A.G & S.G Siddhartha Degree College of Arts & Science, Vuyyuru – 521165.

(An Autonomous College in the jurisdiction of Krishna University)

M.Sc., (Computer Science) Programme – III Semester

Course Code: 21CS3OEL1

Title: Visual Analytics for Executives

(w.e.f admitted batch 2021-22)

Time: 3 Hours

Max. Marks: 70

Part A (Theory)

(5×4 = 20 Marks)

Answer All Questions

1. What is Dimension and Measure?
2. Explain Joining Tables with Tableau with example.
3. Explain the role of Table Data Extract.
4. How to Replace Tableau's Standard Maps?
5. What is Cluster Analysis?

Part B (Practical)

(2×25 = 50 Marks)

Answer all Questions

1. a. Creating word clouds using Tableau.
b. Create a dual axis chart using Tableau.
2. Creating a Simple Dash Board using Tableau.

A.G & S.G Siddhartha Degree College of Arts & Science, Vuyuru – 521165.
(An Autonomous College in the jurisdiction of Krishna University)
M.Sc., (Computer Science) Programme - III Semester

Course	WEB PROGRAMMING		
Course Code	21CS3OEL2	Course Delivery Method	Class Room / Blended Mode
Credits	4	CIA Marks	30
No. of Lecture Hours / Week	4	Semester End Exam Marks	70
Total Number of Lecture Hours	60	Total Marks	100
Year of Introduction :2018	Year of Offering:2021	Year of Revision:2021	Percentage of Revision: 10%

Course Objective: To provide knowledge on Web Architecture, Web Services, Client Side and Server Side Scripting Technologies, To focus on the development of Web Based Information Systems and Web Services, To provide skills to design Interactive and Dynamic Web Sites.

Course Outcomes: On successful completion of the course student will be able to:

CO1: Understand the Web Architecture and Web Services.

CO2: Design Interactive Web Pages using HTML and Style Sheets.

CO3: Design Interactive Web Pages using Forms and Tables.

CO4: Study about CSS and XML.

CO5: Create a Website using Wix Platform.

Syllabus

Unit	Learning Units	Lecture Hours
I	<p>Introduction: What is Internet, History of Internet, Internet Services and Accessibility, Uses of the Internet, Protocols, Web Concepts: The Client/Server Model, Retrieving Data from the Web, How the Web Works?, Web Browsers, Searching information on the Web, Internet Standards.</p> <p>Internet Protocols: Internet Protocols, Host Names, Internet Applications And Application Protocols, Email Protocols.</p> <p>World Wide Web: Basics of WWW and Browsing, URL, Types of Browsers, Features of Browsers.</p>	12
II	<p>Introduction to HTML: HTML Document Structure, Creating Headings on Webpage.</p> <p>Working with Links: Creating Hyper Link, Setting The Hyper Link Colors, Linking Different Sections of Web Page.</p> <p>Working with images: Inserting an Image, Displaying alternate Text for an Image, Adding a Border, Aligning an Image, Using Image as Links, Image Maps.</p> <p>Working with tables: Creating a Table, Specifying Caption to a Table, Adding a Table Heading and Border, Aligning a Table and Cell Content, Setting The Width of a Table And Table Columns.</p>	12
III	<p>Forms: Creating Forms, Named Input Fields, The <INPUT> Tag, Multiple Lines Text Windows, Drop Down and List Boxes, Text, Text Area, Password, Button, Submit, Reset, Radio, Checkbox, Select Option, Labeling Input Fields, Grouping Related Fields, Disabled and Read Only Fields.</p> <p>Frames: Introduction to Frames, Frames Document, The <FRAMESET> Tag, Nesting <FRAMESET> Tag, Placing Content in Frames with the <FRAME> Tag, Targeting Named Frames.</p>	12

IV	<p>CSS: Introduction to Style Sheets, Inline Styles, External Style Sheets, Internal Style Sheets, Style Classes, Multiple Styles.</p> <p>XML: Introduction, HTML vs. XML, Syntax of XML Document, XML Attributes, Use of Elements vs. Use of Attributes, XML Validation, Well Formed XML Documents, Valid XML Documents, XML DTD: Internal DTD, External DTD, The Buildings Blocks of XML Documents.</p>	12
V	<p>Make a Website with Wix: Planning your Wix Website Design, Planning your Website Pages Working, Planning your Website Pictures, Videos and Logos, Wix Signup and Selecting a Premade or Blank Template.</p> <p>Building Your Wix Website: Getting to know Wix platform, Getting to know Wix editor, Designing the Header, Footer and Menu, Background for Pages and Sections, Adding Text, Adding Photos, Adding Videos, Adding Icons, Shapes and Boxes, Adding Links, Adding Forms, Adding a Wix Store, Adding a Lightbox.</p>	12

Prescribed Textbook			
	Author	Title	Publisher
1	N.P.Gopalan, J.Akilandeswari	Web Technologies-A Developer's Perspective	PHI(2008)

Reference Text Book			
	Author	Title	Publisher
1	Harvey M. Deitel and Paul I. Deitel	Internet and World Wide Web How To Program, 5e	Prentice Hall; 4th edition
2	Thomas Powell	Web Design The Complete Reference	TMH Tata McGraw Hill

Course Focus: Employability

Websites of Interest:

3. <https://www.w3schools.com/html/default.asp>
4. <https://www.udemy.com/course/wix-master-course-make-a-website-in-1-day-with-wix>

Time: 3 Hours

Max. Marks: 70

Answer ALL questions

(10×2 = 20 Marks)

1. a. What is Web Browser? Explain it?
- b. What is the Functionality of HTTP?
- c. Compare Tag and Attributes with example.
- d. Describe how you will Embed Images in Web document.
- e. Why do we use <frameset>?
- f. Write tag for Drop Down.
- g. Develop an Inline Style Sheet with suitable example.
- h. What is the Syntax of XML?
- i. How to Plan a Website Design?
- j. Explain adding a photo in Wix Platform.

Answer Five Questions Choosing One Question from Each Unit.

All Questions Carry Equal Marks.

(5×10 = 50 Marks)

Unit I

- 2) a) Explain various Services Offered by Internet and the Types Of Internet Connections.
(or)
b) Explain about Internet Protocols.

Unit II

- 3) a) What is the structure of HTML Document? Explain with example.
(or)
b) How to Create A Table in HTML with various Attributes?

Unit III

- 4) a) Discuss Frame Set and Frame Attributes by writing Program.
(or)
b) Develop a Form with Various Tags with suitable example.

Unit IV

- 5) a) What are Types of CSS? Explain with example.
(or)
b) What are Well Formed and Valid XML Documents?

Unit V

- 6) a) Explain Planning of Wix Website Pages Working, Website Pictures, Videos and Logos.
(or)
b) Explain creating a Website using Wix Platform.

**APPENDIX - IV
ADD ON COURSE**

Applicable for the batch of students applicable during the Academic Year 2021-2022										
M.Sc.(Computer Science)										
III SEMESTER						Add on Course				
S.No.	Course Code	Title of the Course	Instructional Hours per Semester			Credits	Evaluation			Total Marks
			L	T	P		CIA Marks	SEE		
								Marks	Duration	
1	21CS3A1	PHP with My SQL Certification			45	4	Nil	Nil	3 Hours	Nil
CIA=Continuous Internal Assessment					SEE=Semester End Examinations					

**Adusumilli Gopalakrishnaiah & Sugarcane Growers
Siddhartha Degree College of Arts & Science
(Autonomous)**

Vuyyuru-521 165, Krishna District, A.P.

--)00(--



Department of History

Minutes of the meeting of Board of Studies

30.10.2021

**Minutes of the meeting of Board of studies in History for the Autonomous courses of
AG & SG Siddhartha Degree College of Arts & Science, Vuyyuru, held at
10.30 A.M on 30-10-2021**

K.Kiran* *Presiding

Members Present:

- | | |
|---|---|
| 1)..... Chairman
(Sri.K.Kiran) | Head, Department of History
AG & SG S Degree College of Arts & Science
Vuyyuru-521165 |
| 2)..... University
(Dr.M.Suseela Rao) Nominee | Head, Department of History
Government Degree College
Mylavaram. |
| 3) Subject Expert
(Dr.D.Rajya Lakshmi) | Lecturer in History
Government Degree college
Avanigadda |
| 4)..... Subject Expert
(Smt.N.Jhansi) | Head,Department of History
S.D.M.S Mahila Kalasala,
Vijayawada |

AGENDA

1. To Review and recommend any changes in the syllabi, Model Question Papers and Guidelines of 1st, 3rd, and 5th Semesters of I, II and III Year B.A. Economics Papers for the Academic Year 2021-2022.
2. To Discuss and recommend the pattern of internal Assessment , Guidelines and Model Question Papers in 1st 3rd and 5th Semesters of B.A Degree Economics papers for the Academic Year 2021-2022.
3. To Recommend the guidelines to be followed by the Question Paper Setters in for the 1st, 3rd and 5th Semester-end exams.
4. To Recommend the teaching and evaluation methods to be followed under the Autonomous Status.
5. To Propose the panel of Question paper setters and Examiners.
6. To Suggest innovative methods of teaching.
7. Any other matter.

RESOLUTIONS:

1) It is Resolved to continue the same syllabi under CBC System approved by the Academic council of 2020- 2021 for 1st Degree in I Semester & III Degree in V Semester History papers, of B.A Classes.

The APSHE New syllabus was introduced in the I Semester of I Degree B.A from the Academic year 2020 – 2021 and in the III Semester of II Degree B.A From the Academic year 2021 – 2022.

2) Out of maximum 100 marks in each paper 30 marks shall be allocated for Internal Assessments regarding III and V Semesters.

A) To implement 30 marks for internal assessment and 70 marks for External Assessment from the academic year 2019-20 and that is also implemented to the III and V Semesters from 2020-21 Academic year and 2021 – 2022 Academic year also.

B) Out of these 30 marks, 20 marks are allocated for internal tests, 5 marks are allocated for assignment for III and V Semesters. The two tests will be conducted and average of these two tests shall be deemed as the marks obtained by a student, and remaining 5 marks are allocated for attendance.

3) Out of maximum 100 marks 25 Marks shall be allocated for Internal Assessments Regarding the I Semester from the Academic year 2021 – 2022.

A) To implement 25 Marks for Internal Assessments and 75 Marks for External Assessment regarding the I Semester from the Academic year 2021 – 2022.

B) Out of these 25 marks, 20 Marks are allocated for internal tests, 5 marks are Allocated for assignment/ attendance Regarding the I Semester from the Academic year 2021 – 2022.

4) Discussed and recommended the syllabi, Model question papers under CBC system and guidelines to be followed by the question paper setters of 1st semester of I, III and V semesters of B.A Classes for the Academic year 2021-2022.

- 5) To follow the teaching and evaluation methods, it is also resolved to use various other methods like Group discussions, Quiz, Organizing Seminars, Guest Lectures and Workshops to upgrade the knowledge of the students and impart new skills of learning as frequently as possible.
- 6) Resolved to authorize the chairman of Board of studies to suggest the panel of paper setters and Examiners to the controller of Examinations as for the requirement.
7. It is resolved to follow further changes if any in the syllabus by the competent Authority.

Chairman

SEMESTER-I

Course Code	Title of the Course	Instruction Hours per week	Credits	Evaluation		
				CIA MARKS	SEE	
					MARKS	DURATION
HIS-101	ANCIENT INDIAN HISTORY & CULTURE FROM INDUS VALLEY CIVILIZATION TO 13TH CENTURY A. D	5	4	25	75	3Hrs

SEMESTER-III

Course Code	Title of the Course	Instruction Hours per week	Credits	Evaluation		
				CIA MARKS	SEE	
					MARKS	DURATION
HIS-301	MODERN INDIAN HISTORY & CULTURE (1764-1947 A. D)	5	4	30	70	3Hrs

SEMESTER-V

Course Code	Title of the Course	Instruction Hours per week	Credits	Evaluation		
				CIA MARKS	SEE	
					MARKS	DURATION
HIS-501	Age of Rationalism and Humanism –The World Between 15th& 18th Century	5	4	30	70	3Hrs
HIS-502	History & Culture of Andhra Desa (from 12th to 19th Century A.D)	5	4	30	70	3Hrs

S No.	Programme Specific Outcomes Upon completion of BA Degree Programme with History combination the graduates will be able to:
PSO-1	To understand the History of People and societies like religious, customs institution Administration.
PSO-2	To create an awareness of different political cultural social and economic structures in the past and their Interrelationship.
PSO-3	Analyze relationship between the past and the present is lively presented in the history.
PSO-4	To prepare students for future study employability and responsible citizenship. a) Further study-post graduate in history, B.Ed, M.Phil, Ph.D b) Employability – Archaeologists, Historians, UPSC- jobs APPSC-Jobs, Teachers, NGO’s Travel and Tourism experts.
PSO-5	To develop interest in the study of History and activities, skills relating to history. a) Draw historical Maps, Charts b) Collect ancient arts, coins c) Visit Archaeological sites, Museums, archives and Historical important places. d) To take active role in activities of historical organizations.
PSO-6	Empowering students in the historical research and to write articles on historical topics.
PSO-7	Inculcate moral and ethical values among students.
PSO-8	To install the feeling of patriotism among the students.
PSO-9	To orient student to become perfect social being.



A. G & S.G. SIDDHARTHA DEGREE COLLEGE OF ARTS & SCIENCE

Vuyyuru-521165.

NAAC reaccruited at 'A' level

Autonomous -ISO 9001 – 2015 Certified

TITLE OF THE PAPER: ANCIENT INDIAN HISTORY & CULTURE FROM INDUS VALLEY CIVILIZATION TO 13TH CENTURY A. D

Semester: I

Course Code	HIS-101	Course Delivery Method	Class Room / Blended Mode - Both
Credits	4	CIA Marks	25
No. of Lecture Hours / Week	5	Semester End Exam Marks	75
Total Number of Lecture Hours	60	Total Marks	100
Year of Introduction:	Year of Offering: 2021 - 22	Year of Revision: ----	Percentage of Revision: 0%
CLASS:	1.B.A		

Learning objectives:

1. To Identify the various kinds of sources and various stages of Indian civilization and religions like Buddhism and Jainism
2. To impart knowledge about religions like Buddhism and Jainism and Mouryan empire.
3. Inculcating awareness on ancient kingdoms of south Indian rulers.
4. Enlighten them with great Indian rulers like Gupta 's and Harshvardhan.
5. To provide the knowledge about the Cholas and Kakatiyas

Course Outcomes:

1. It encourages students to think explicitly about the aims of Indian history and culture
2. Acquire knowledge of Indian religions such Buddhism and Jainism. Acquainted with Indian kingship and culture -Mouryas and Satavahanas
3. Evaluate the south Indian administration and cultural contribution of Pallavas.
4. Ancient knowledge of golden age Guptas and cultural contribution oh Harsha.
5. Evaluate the administration of Cholas and greatness of Kakatiyas.

ANCIENT INDIAN HISTORY & CULTURE FROM INDUS VALLEY CIVILIZATION TO 13TH CENTURY A. D

SYLLABUS

Unit - 1 **12 hrs**

- 1.1- Ancient Indian Civilization (from Circa 3000 BC to 6th BC):
 - 1.2 Indus Valley Civilization - Salient Features
 - 1.3 Vedic Age - Society, Polity, Economy, Culture during early and later Vedic period (On line)

Unit - II **12 hrs**

- 2.1- Ancient Indian History & Culture (6th Century BC to 2nd Century AD):
- 2.2- Doctrines and Impact of Jainism and Buddhism;
- 2.3- Mauryan Administration, Society, Economy & Culture - Ashoka's Dharma;
- 2.4- Kanishka's Contribution to Indian Culture (On line)

Unit - III **12 hrs**

- 3.1- History & Culture of South India (2nd Century BC to 8th Century AD):
- 3.2 Sangam Literature; Administration, Society, Economy and Culture under Satavahanas
- 3.3 Cultural contribution of Pallavas (On line)

Unit - IV **12 hrs**

- 4.1- India from 3rd century AD to 8th century AD: Administration, Society, Economy, Religion, Art, Literature and Science & Technology under Guptas - Samudragupta.
- 4.2- Cultural contribution of Harsha:
- 4.3 Arab Conquest of Sind and its Impact

Unit - V **12 hrs**

- 5.1- History and Culture of South India (9th century AD to 13th century AD):
- 5.2 Local Self Government of Cholas
- 5.3 Administration, Society, Economy and Culture under Kakatiyas - Rudramma Devi

CO-CURRICULAR ACTIVITIES AND ASSESSMENT METHODS:

Continuous Evaluation:

1. Monitoring the students' progress of learning by Class Tests.
2. Map pointing
3. Projects, Assignments and Group Discussions, Enhances critical thinking skills and Personality.
4. Semester-End Examination: Critical indicator of students learning and teaching methods adopted by teachers throughout the semester

REFERENCES:

1. A.L. Basham, The Wonder That Was India
2. D.N.Jha, Ancient India
3. D.D.Kosambi, An Introduction to the Study of Indian History
4. D.P.Chattopadhyay, Science and Society in Ancient India
5. B.N.Mukherjee, The Rise and Fall of the Kushana Empire
6. K.A. NilakanthaShastri, A History of South India
7. R.C.Majumdar, K.K.Dutta&H.C.RoyChowdhuri (ed.), Advanced History of India
8. Kumkum Roy, The Emergence of Monarchy in North India: eighth to fourth centuries BC
9. RomilaThapar (et. al). India: Historical Beginnings and the Concept of the Aryan
10. M.L.K. Murthy, Pre-and Protohistoric Andhra Pradesh upto 500 B.C., New Delhi, 2003
- 11 K. Sathyanarayana, A Study of the History and Culture of Andhras

**ANCIENT INDIAN HISTORY & CULTURE FROM INDUS VALLEY CIVILIZATION
TO 13TH CENTURY A. D**

Model Question Paper
B.A/ HEP – I semester

Time : 3 hrs

Max. Marks : 75

PART – A

I. Answer any FIVE of the following :
(one Questions to be set from each unit)

5 x 5=25 M

1. Explain the Archeological Sources Co1 L2
2. Explain Mahavira and his teachings Co1 L2
3. Analyse Ashoka's contributions to Buddhism Co2 L3
4. Explain the role of Kanishka. Co2 L2
5. What are the main aspects of Sangam age Co3 L1
6. Estimate the invasions of SamudraGupta Co4 L4
7. Analyse Arab invasions. Co4 L3
8. Estimate the role of Raja Raja Chola Co5 L4

PART – B

II. Answer any FIVE of the following:
(one Questions to be set from each unit)

5 x 10= 50 M

1.
 - A) Explain about the Indus Valley Civilization. Co1 L2

OR

 - b.)What are the main features of Vedic civilization Co1 L1
2.
 - A).Explain Early life and teachings of Buddha. Co2 L2

OR

 - b.)Examine about Mauryan administration Co2 L3
3.
 - A)Explain the general conditions of Satavahana's. Co3 L2

OR

 - b.)Define the cultural contribution of Pallava's Co3 L1
4.
 - A)Illustrate the Golden age of Gupta's Co4 L2

OR

 - b.)Define the role of Harshavardhana in Indian History Co4 L1
5.
 - A) Explain Chola's administration Co5 L2

OR

 - b.)Examine the administration of Kakatiyas Co5 L3



A. G & S.G. SIDDHARTHA DEGREE COLLEGE OF ARTS & SCIENCE

Vuyyuru-521165.

NAAC recredited at 'A' level

Autonomous -ISO 9001 – 2015 Certified

TITLE OF THE PAPER: MODERN INDIAN HISTORY & CULTURE (1764-1947 A. D)

Semester: – III

Course Code	HIS301	Course Delivery Method	Class Room / Blended Mode - Both
Credits	4	CIA Marks	30
No. of Lecture Hours / Week	5	Semester End Exam Marks	70
Total Number of Lecture Hours	60	Total Marks	100
Year of Introduction:	Year of Offering: 2021 - 22	Year of Revision: ----	Percentage of Revision: 0%
CLASS:	II.B.A		

Learning Outcomes:

After successful completion of this course, the student will be able to:

- 1.To understand about the Socio-religious reform movement in 19th C. and self respect movements.
- 2.Realise the Lord Rippons local self government and Lord Curzon policy.
- 3.Establishment of Indian National congress and state the role of moderate and extremists.
- 4.Understand the Gandhi role in Indian National movementcomparison of Nationalist movement pre Gandhi – past Gandhi era.
5. Asses the partition of India and Integration of Native states into Indian union.

References:

- 1 Anil Seal, Emergence of Indian Nationalism
- 2 Banerjee, Sekhar, From Plassey to Partition
- 3 Bipan Chandra, Rise and Growth of Economic Nationalism in India
- 4 Chandra, Bipan, et. al., India's Struggle for Independence
- 5 Bipan Chandra, Modern India
- 6 Joshi, P.C., Rammohun and the Forces of Modernisation in India
- 7 R.P.Dutt, India Today

Mandatory Co-Curricular Activity:

Map pointing should be a compulsory activity as it helps student to understand vividly and clearly than the text and should be made part of Internal Examination by allotting marks for this skill-based activity.

Suggested Co- Curricular Activities:

Debates

Viva voce interviews

Quiz Programs

Photo Album

Recording local history

Role Play of freedom struggle events

Organizing photo exhibition on freedom fighters

Celebration of important events/personalities

Conducting Philately

Examinations (Scheduled and surprise tests)

Students may be asked to prepare a project on the difference between Mughal and British administration

Encourage students to write their autobiography or biography of their inspiring Personalities

AG & SG SIDDHARTHA DEGREE COLLEGE OF ARTS & SCIENCE VUYYURU

A.P- 521165b (2021 – 2022)

(An autonomous college in the jurisdiction of Krishna university, Machilipatnam)

(2021 – 2022)

II BA. Semester – III (CBCS) Paper – III

Subject; History

Title of the Paper – MODERN INDIAN HISTORY & CULTURE (1764-1947 A. D)

Paper Code; HIS-301 (w .e. f 2021 - 2022)

Pass Marks: 28

Time: 3Hrs

Max. Marks: 70

Model Question Paper

SECTION – A

Answer any TWO of the following

2x5=10 M

1. Home Rule League.
2. Swamy Vivekananda.
3. Identify the Places in Indian Map
A) Delhi B) Tanjavor C) Meerat D) Kanpur E) Ayodhya.
4. Identify the Places in Indian Map
A) Kashmir B) Hyderabad C) Junagadh D) Patna E) Bengal.

SECTION – B

Answer any FOUR of the following

4x15=60 M

5. Describe about the causes of 1857 Revolts
6. Give a brief account on contribution of Raja Rama mohan Rai to Socio – Religious movements.
7. Explain the role of Dr.B.R Ambedkar in Social Reforms.
8. Explain about the Swamy Vivekananda
9. Write an Essay on Vandematharam Movement.
10. Explain about the Non Cooperation Movement.
11. Explain the Role of Gandhiji in Indian National Movement.
12. Describe the Role of Valla bhai Patel in Integration of province states in India.

AG & SG SIDDHARTHA DEGREE COLLEGE OF ARTS & SCIENCE VUYYURU
A.P- 521165 (2021 – 2022)

(An autonomous college in the jurisdiction of Krishna university, Machilipatnam)

SUBJECT- History	HIS 301	II B.A
------------------	---------	--------

TITLE: MODERN INDIAN HISTORY & CULTURE (1764-1947 A. D)

Semester – III

Guidelines to the Paper Setter

Section	Unit – I	Unit – II	Unit – III	Unit - IV	Unit-V
A 5 Marks Questions	1	1	1	---	1
B 15 Marks Questions	2	2	1	2	1
Weightage	35	35	20	30	20



A. G & S.G. SIDDHARTHA DEGREE COLLEGE OF ARTS & SCIENCE

Vuyyuru-521165.

NAAC reaccredited at 'A' level

Autonomous -ISO 9001 – 2015 Certified

TITLE OF THE PAPER: Age of Rationalism and Humanism –The World Between 15th & 18th Centuries.

Semester: – V

Course Code	HIS-501	Course Delivery Method	Class Room / Blended Mode - Both
Credits	4	CIA Marks	30
No. of Lecture Hours / Week	5	Semester End Exam Marks	70
Total Number of Lecture Hours	60	Total Marks	100
Year of Introduction:	Year of Offering: 2021 - 22	Year of Revision: ----	Percentage of Revision: 0%
CLASS:	11.B.A		

Learning Outcomes:

After successful completion of this course, the student will be able to:

- 1.Describe the geographical discoveries-feudalism.**
- 2.Assess the causes and effects of Renaissance, Reformation and Counter Reformation movements.**
- 3.Narrate the emergence of National states and Glorious Revolution.**
- 4.Assess the causes and effects of American Revolution.**
- 5.Realize the causes and results of French revolution and the revolution gave Liberty, Fraternity, and Equality.**

**Age of Rationalism and Humanism –The World Between 15th& 18th Centuries.
Syllabus**

Unit – 1

Feudalism -Geographical Discoveries: Causes – Compass & Maps – Portugal Leads and Western World Follows – Consequences;(10 Hrs)

Unit – II

The Renaissance Movement: Factors for the Growth of Renaissance – Characteristic Features - Transformation from Medieval to Modern World; Reformation & Counter Reformation Movements: The Background – Protestantism – Spread of the Movement– Counter Reformation– Effects of Reformation(12Hrs)

Unit - III

Emergence of Nation States: Contributory Factors - England and other Nation States – Impact due to the Emergence of Nation States.; Age of Revolutions: The Glorious Revolution (1688) – Origin of Parliament – Constitutional Settlement – Bill of Rights – Results(10Hrs)

. Unit – IV

Age of Revolutions: The American Revolution (1776) – Opening of New World – Causes – Course – Declaration of Independence, 1776 – Bill of Rights, 1791 – Significance(12Hrs).

Unit – V

Age of Revolutions: The French Revolution (1789) – Causes - Teachings of Philosophers - Course of the Revolution – Results(16Hrs)

References:

- 1 Burke, Peter, the Renaissance
- 2 C.J.H. Hayes, Modern Europe up to 1870
- 3 C.D. Hazen, Modern Europe up to 1945
- 4 Christopher Hill, From Reformation to Industrial Revolution
- 5 Elton, G.R., Reformation Europe, 1517-1559
- 6 Ferguson, the Renaissance
- 7 Gilmore, M.P., the World of Humanism, 1453-1517
- 8 Hilton, Rodney, Transition from Feudalism to Capitalism
- 9 J.H.Parry, the Age of Renaissance
- 10 J.N.L. Baker, History of Geographical Discoveries and Explorations
- 11 the New Cambridge Economic History of Europe, Vol. I, VII.

**AG & SG SIDDHARTHA DEGREE COLLEGE OF ARTS & SCIENCE VUYYURU
A.P- 521165**

(An autonomous college in the jurisdiction of Krishna university, Machilipatnam)

(2021 – 2022)

III BA.Semester – V (CBCS) Paper – V

Subject; History

Title of the Paper – Age of Rationalism and Humanism –The World Between 15th& 18th Centuries.

Paper Code ; HIS-501 (w .e. f 2020 - 2021)
Time : 3Hrs

Pass Marks: 28
Max. Marks : 70

Model Question Paper

SECTION – A

Answer any TWO of the following

2x5=10 M

1. Geographical Discoveries
2. Counter Reformation
3. Boaston Tea Party
4. Reign of Terror

SECTION – B

Answer any FOUR of the following

4x15= 60 M

5. Analyse the features Feudalism
6. Explain the important features of Renaissance
7. What is Reformation Movement and its significance
8. Describe the causes for the emergence of Nation States
9. Give a brief account of Glorious Revolution
10. Discuss about the causes of American Revolution
11. Write an essay on causes for the French Revolution
12. Estimate the rule of Directory in France.

AG & SG SIDDHARTHA DEGREE COLLEGE OF ARTS & SCIENCE VUYYURU

A.P- 521165

(An autonomous college in the jurisdiction of Krishna university, Machilipatnam)

(2021 – 2022)

SUBJECT- History	HIS 501	III B.A
------------------	---------	---------

TITLE: Age of Rationalism and Humanism –The World Between 15th& 18th Centuries.

Semester – V

Guidelines to the Paper Setter

Section	Unit – I	Unit – II	Unit – III	Unit - IV	Unit-V
A 5 Marks Questions	1	1	-	1	1
B 15 Marks Questions	1	2	2	1	2
Weightage	20	35	30	20	35



A. G & S.G. SIDDHARTHA DEGREE COLLEGE OF ARTS & SCIENCE

Vuyyuru-521165.

NAAC reaccruited at 'A' level

Autonomous -ISO 9001 – 2015 Certified

TITLE OF THE PAPER: – History & Culture of Andhra Desa (from 12th to 19th Century A.D)

Semester: – V

Course Code	HIS-502	Course Delivery Method	Class Room / Blended Mode - Both
Credits	4	CIA Marks	30
No. of Lecture Hours / Week	5	Semester End Exam Marks	70
Total Number of Lecture Hours	60	Total Marks	100
Year of Introduction:	Year of Offering: 2021 - 22	Year of Revision: ----	Percentage of Revision: 0%
CLASS:	III BA		

Learning Outcomes:

After successful completion of this course, the student will be able to:

- 1.To understand the Socio-Economic and cultural condition of Andhra during Kakatiyas rule
Identity the contribution of Vijayanagara rulers to Art and Architecture, literature and
greatness of SrikrishnaDevaraya**
- 2.To narrate the Socio –Economic condition Andhras during the Qutubshahi rule and their
Administration**
- 3.Describe the advent of Europeans in Andhra**
- 4.Evaluate the establishment of British rule in Andhra and 1857 revolt.**

Syllabus
History & Culture of Andhra Desa (from 12th to 19th Century A.D)

Unit – 1

Andhra during 12th & 13th Centuries A.D.: Kakatiyas – Origin & its Antecedents – Administration – Social & Economic Life – Industries & Trade - Promotion of Literature and Culture – Architecture & Sculpture – Decline; The Age of Reddy Kingdoms: Patronage to Literature – Trade & Commerce.(12Hrs)

Unit – II

Andhra between 14th & 16th Centuries A.D.: Vijayanagara Empire: Polity, Administration, Society & Economy – Sri Krishna Devaraya and his contribution to Andhra Culture – Development of Literature & Architecture – Decline and Downfall.(10Hrs)

Unit - III

Andhra through 16th & 17th Centuries A.D.: Evolution of Composite Culture – The QutbShahis of Golkonda – Origin & Decline – Administration, Society & Economy – Literature & Architecture.(10Hrs)

Unit – IV

The 18th & 19th Centuries in Andhra: East India Company's Authority over Andhra – Three Carnatic Wars – Occupation of Northern Circars and Ceded Districts – Early Uprisings – Peasants and Tribal Revolts.(14Hrs)

Unit – V

The 18th & 19th Centuries in Andhra: Impact of Company Rule on Andhra – Administration – Land Revenue Settlements – Society – Education - Religion – Impact of Industrial Revolution on Economy – Peasantry & Famines – Contribution of Sir Thomas Munroe, C. P. Brown & Sir Arthur Cotton – Impact of 1857 Revolt in Andhra.(14Hrs)

References:

- 1 BalenduSekharam, TheAndhras Through the Ages
- 2 K. Sathyanarayana, A Study of the History and Culture of Andhras
- 3 Mallampalli Soma SekharaSarma, History of the ReddiKindogms
- 4 K.A.N.Sastry, A History of South India
- 5 H.K.Sherwani, History of the KutubShahi Dynasty
- 6 P.R.Rao, History of Modern Andhra
- 7 KhandavalliLakxmiranjanam&BalenduSekharam
- 8 SuravaramPratap Reddy
- 9 B.S.L.HanumantaRao
- 10 I.K.Sarma, *Early Historic Andhra Pradesh, 500 B.C.-624 A.D.*, New Delhi, 2008
- 11 B. Rajendra Prasad, *Early Medieval Andhra Pradesh, A.D.624 -1000 A.D.*, New Delhi, 2009
- 12 C. SomasundaraRao, *Medieval Andhra Pradesh, A.D. 1000 -1324 A.D.*, New Delhi, 2011

AG & SG SIDDHARTHA DEGREE COLLEGE OF ARTS & SCIENCE VUYYURU,A.P- 521165
(An autonomous college in the jurisdiction of Krishna university, Machilipatnam)

III BA. Semester – V (CBCS) Paper – VI

Subject:: History

Title of the Paper – History & Culture of Andhra Desa (from 12th to 19th Century A.D)

Paper Code; HIS-502

(w .e. f 2020 - 2021)

Pass Marks: 28

Time : 3Hrs

Max. Marks: 70

Model Question Paper

SECTION – A

Answer any TWO of the following

2x5=10

1. Rudrama Devi
2. Battle of Tallikota
3. Abdul Hasan Tanisha
4. Sir Arthur Cotton

SECTION – B

Answer any FOUR of the following

4x15=60

5. Write an essay on Socio-Economic and Cultural conditions of Kakatiyas
6. Discuss the glory of Vijayanagara Empire
7. Briefly explain the Administrative system of Qutub Shahis
8. Write about the general conditions of Andhra in 17th Century
9. Give a brief account of Carnatic Wars in Deccan
10. Explain about the Acquisition of Northern Circars by British
11. Describe the greatness of Thomas Munroe
12. Estimate the impact of 1857 Revolt in Andhra.

AG & SG SIDDHARTHA DEGREE COLLEGE OF ARTS & SCIENCE VUYYURU
A.P- 521165

(2021 – 2022)

(An autonomous college in the jurisdiction of Krishna university, Machilipatnam)

SUBJECT- History	HIS 502	III B.A
------------------	---------	---------

TITLE: History & Culture of Andhra Desa (from 12th to 19th Century A.D)

Semester – V

Guidelines to the Paper Setter

Section	Unit – I	Unit – II	Unit – III	Unit - IV	Unit-V
A 5 Marks Questions	1	1	1	-	1
B 15 Marks Questions	1	1	2	2	2
Weightage	20	20	35	30	35

**Adusumilli Gopalakrishnaiah & Sugarcane Growers
Siddhartha Degree College of Arts & Science
(Autonomous)**

Vuyyuru-521 165, Krishna District, A.P.

--)00(--



Department of Political Science

Minutes of the meeting of Board of Studies

30.10.2021



**A.G & S.G SIDDHARTHA DEGREE
COLLEGE OF ARTS AND
SCIENCE::VUYYURU**

(An Autonomous College in the Jurisdiction of Krishna University)
Accredited at the level 'A' by the NAAC
Sponsors: Siddhartha Academy of General & Technical Education

DEPARTMENT OF POLITICAL SCIENCE

Minutes of the meeting of Board of Studies in Political Science of A.G. & S.G. Siddhartha Degree College of Arts & Science, Vuyyuru held at 10:00 A.M on 30/10/2021 in the Department of Political Science

Members Present		
Name of the Member	Role	Signature
Smt. Ch. Sandhya Rani, HOD, Dept. of Political Science, A.G & S.G. Siddhartha Degree College of Arts & Science, Vuyyuru-521165. Mobile: 9949402837 E-Mail: narasandhyarani@gmail.com	Chairman	
Sri. M. Padhmanabham, Assistant Professor, Dept of Political Science, SRR & CVR Govt Degree College, Vijayawada. Mobile: 9490772836	University Nominee, Krishna University	
Smt G.Padmaja, Head, Department of Political Science, S.D.M. Siddhartha Mahila Kalasala, Vijayawada. Mobile: 9441883417	Academic Council Nominee	
Dr.G.Veerraju, H.O.D & Assistant Professor, Dept of Political Science, Y.V.N.R Govt. Degree College, Kaikaluru. Mobile: 9440476494	Academic Council Nominee	
Sri. R.V.Siva Rao, Lecturer Dept. of Political Science, A.G & S.G Siddhartha Degree College of Arts & Science, Vuyyuru-521165. Mobile:9391380250	Academic Council Member	



A.G & S.G SIDDHARTHA DEGREE COLLEGE OF ARTS AND SCIENCE::VUYYURU

(An Autonomous College in the Jurisdiction of Krishna University)

Accredited at the level 'A' by the NAAC

Sponsors: Siddhartha Academy of General & Technical Education

DEPARTMENT OF POLITICAL SCIENCE

Minutes of the meeting of Board of Studies in Political Science of A.G. &S.G Siddhartha Degree College of Arts & Science, Vuyyuru held at 10:00 A.M On 30/10/2021 in the Department of Political Science

Members Present		
Name of the Member	Role	Signature
Smt. Ch. Sandhya Rani, HOD, Dept. of Political Science, A.G & S.G Siddhartha Degree College of Arts & Science, Vuyyuru-521165. Mobile: 9949402837 E-Mail: narrasandhyarani@gmail.com	Chairman	
Sri. M. Padhmanabham, Assistant Professor, Dept of Political Science, SRR & CVR Govt Degree College ,Vijayawada. Mobile: 9490772836	University Nominee, Krishna University	
Smt G.Padmaja, Head, Department of Political Science, S.D.M. Siddhartha Mahila Kalasala, Vijayawada. Mobile: 9441883417	Academic Council Nominee	
Dr.G.Verraju, H.O.D & Assistant Professor, Dept of Political Science, Y.V.N.R Govt. Degree College, Kaikaluru. Mobile: 9440476494	Academic Council Nominee	
Sri. R.V.Siva Rao, Lecturer Dept. of Political Science, A.G & S.G Siddhartha Degree College of Arts & Science, Vuyyuru-521165. Mobile:9391380250	Academic Council Member	

AGENDA

1. To review and recommend changes to syllabi, model paper and guidelines in the 1st, 3rd and 5th semesters of B.A
2. To discuss about and recommend the pattern of assessment i.e., internal and external assessment percentage to be followed for Third Semester from academic year 2021-2022
3. To recommend the the guidelines to be followed by the Question Paper Setters in Political Science for all semester-end exams.
4. To recommend the teaching and the evaluation methods to be followed under the Autonomous System.
5. To Suggest innovative methods of teaching
6. To propose the panel of Question Paper Setters and Examiners.

RESOLUTIONS

Following resolutions are made in the Board of Studies in Political Science :

- 1) It is resolved to include INTRODUCTION TO POLITICAL SCIENCE in the place of BASIC CONCEPTS OF POLITICAL SCIENCE for Semester-I for the 1st Degree from the Academic Year 2021-2022.
- 2) It is resolved to introduce INDIAN GOVERNMENT AND POLITICS in the place of INDIAN CONSTITUTION for semester-III for the 2nd Degree from the Academic Year 2021-2022.
- 3) To continue with the existing syllabi for 5th semester without any change for the Academic Year 2021-2022.
- 4) To adapt 25 marks for internal assessment and 75 marks for external assessment for 1st Degree and 30 marks for internal assessment and 70 marks for external assessment for 2nd and 3rd year Degree from the Academic Year 2021-2022.
- 5) To follow the new model question paper from the Academic Year 2021-2022 for all the B.A Students
- 6) To adapt the following teaching and evaluation methods:

Teaching Methods:

Besides the conventional methods of teaching, it is also resolved to use various other methods like group discussions, quiz, developing power point presentation etc., for the better understanding of the contents.

Evaluation Method for Internal Theory Examination for 1st B.A students

First Internal Exam	Second Internal Exam	Average	Attendance	Total
A	B	$C=(A+B) / 2$	D	(C+D)
20 Marks	20 Marks	20 Marks	5 Marks	25 Marks

Evaluation Method for Internal Theory Examination for 2nd and 3rd B.A students

First Internal Exam	Second Internal Exam	Average	Assignment	Attendance	Total
A	B	$C=(A+B) / 2$	D	E	(C+D+E)
20 Marks	20 Marks	20 Marks	5 Marks	5 Marks	30 Marks

- 7) Semester End Examinations:

- 8) The maximum marks of sem-end examinations for 1st B.A are 75 and for 2nd and 3rd B.A students are 70 Marks from the Academic Year 2021-2022 for all the B.A Students and the duration of the examination shall be 3 Hours.
- 9) To Organize Seminars ,Guest Lectures and Workshops to upgrade the knowledge of the students and to impart new skills of learning as frequently as possible.
- 10) To authorize the chairman of board of studies to suggest the panel of paper setters and examiners to the controller of examinations as per the requirement.

A.G &S.G SIDDHARTHA DEGREE COLLEGE OF ARTS & SCIENCE VUYYURU-521165

(An Autonomous College in the jurisdiction of Krishna University , Machilipatnam)

Title of the paper: INTRODUCTION TO POLITICAL SCIENCE

Semester-I

Course Code	POLTIIB	Course Delivery Method	Class Room
Credits	4	CIA Marks	25
No.of Lecture Hours/Week	5	Semester End Exam Marks	75
Total Number of Lecture Hours	60	Total Marks	100
Year of Introduction 2020-2021	Year of offering 2021-2022	Year of Revision 2021-2022	Percentage of Revision 0%

Course Context and overview: To train students in order to have clear understanding of politics, related concepts such as government, state sovereignty, legitimacy, power, influence, authority, democracy, power, political participation, political system etc.

COURSE OUTCOMES: INTRODUCTION TO POLITICAL SCIENCE

Course Outcomes: At the end of the course the student will be able to:

CO1: Define important field-specific theories and concepts, and understand their role in developing political science Knowledge: L-1 , L-2

CO2: Summarize conceptual arguments or theoretical approaches. L-3 , L-4

CO3: Apply them to field relevant situations and support their application with appropriate evidence. L-3, L-4

CO4: Compare and evaluate the merits of multiple policies, theories or concepts from different disciplinary perceptions. L-5

CO5: With the course, students are expected to learn the political concepts and theory in the Basic Concepts of Political Science. L-1, L-2

Learning Outcome:

On successful completion of the course the students will be able to:

- Recall the previous knowledge about Political Science and understand the nature and scope, traditional and modern approaches of Political Science.
- Understand concepts intrinsic to the study of Political Science.
- Have a solid theoretical understanding of Rights and its theories along with the basic aspects of certain political ideologies.
- Apply the knowledge to observe the field level phenomena.

UNIT:I INTRODUCTION:

15hrs.

1. Definition, Nature, Scope and Importance of Political Science - Relations with allied Disciplines (History, Economics, Philosophy and Sociology)
2. Approaches to the study of Political Science:
Traditional Approaches- Historical, Normative and Empirical Approaches.
Modern Approaches:Behavioral and System Approach.

UNIT-II: STATE :

15 hrs

Definition of the State, Elements of the State, Theories of Origin of the State-(Divine Origin , Force, Evolutionary and Social Contract),

1. Concepts of Modern State and Welfare State.

UNIT-III: CONCEPTS OF POLITICAL SCIENCE:

10 hrs

1. Law, Liberty,
2. Power, Authority and Legitimacy

UNIT:IV: THEORIES OF RIGHTS:

10 hrs

2. Meaning, Nature and Classification of Rights
3. Theories of Rights.

UNIT:V:POLITICAL IDEOLOGIES:

10 hrs

1. Liberalism, Individualism and Anarchism.
2. Socialism, Marxism and Multiculturalism.

REFERENCE BOOKS:

1. Sukhbir Bhatnagar : Constitutional Law and the Governance
2. A. C. Kapur : Select Constitution
3. R.C. Agarwal : Political Theory
4. Vidyadhar Mahajan : Political Theory(Principles of Pol.Sci.
5. Devi & V. Bhogendra Acharya,
6. Prof. V. Ravindra Sastry (ed) : Political Science Concepts, Theories & Institutions.
7. Jadi Musalaiah, V. Vasundhara
8. Laski H.J. : Grammar of Politics
9. A. Appadorai : Substance of Politics
10. Eddy Ashirvadam K.K. Misra : Political Theory
11. Sushila Ramaswamy : Political Theory: Ideas & Concepts
12. S.P. Varma : Modern Political Theory
13. O.P. Gauba : An Introduction to Political Science
14. Abbas, Hoveyda & Ranjay Kumar : Political Theory
15. Andrew Hakes : Political Theory, Philosophy, Ideology Science.
16. Rajeev Bhargava & Ashok Acharya (ed) : Political Theory An Introduction
17. Andrew Heywood : Political Ideologies-An Introduction
18. Norman Barry : An Introduction to Modern Political theory.

(An Autonomous college in the jurisdiction of Krishna University, Machilipatnam)

Reaccredited at 'A Grade by NAAC

MODEL QUESTION PAPER (Semester-I) Course Code : POLTIIB

Time: 3 Hours

Max. Marks : 75

SECTION –A

Answer any five of the following questions.

Each carries **FIVE** marks :

(5X5=25 Marks)

- 1.What is Political Science? L1- CO1
- 2.System Approach? L1 - Co1
- 3.Explain Divine Origin Theory. L1 – L2-Co2
- 4.Discuss 'Hobbes views on Human Nature. L5-Co2
- 5.Describe the features of Welfare State. L5 – CO2
6. Explain the features of Modern State. L2-CO2
- 7.Explain the meaning and sources of Law. L2-Co3
8. Explain the types of Authority. L2,CO3

SECTION –B

Answer the following : Each carries TEN marks.

(5x10=50 Marks)

9.(a) Define Political Science and explain its Scope. L1-CO1

(or)

(b)Explain the 'Normative Approach ' to the study of Political Science. L2-L4-CO1

10 (a)Define State and Elements its characteristics. Co2-L1

(or)

(b) Critically examine the Social Contract Theory of Hobbes. L1-L2-CO1

11. (a) What is Liberty? What are the kinds of Liberty? L2-L4-CO3

(or)

(b) Define Legitimacy and kinds of Legitimacy. L1-L2-COCo3

12. (a) 'Rights and Duties are the two sides of the same Coin' - Discuss.. L1-L5-Co4

(or)

(b) Define Right and discuss various kinds of Rights.. L2-CO4

13. (a) Critically examine 'Communism'. L5-Co5

(or)

(b) Explain the "Multiculturalism". L2-L3-Co1-Co5

New syllabus

B.A. POLITICAL SCIENCE SECONDYEAR

THIRD SEMESTER (Under CBCS w.e.f2020-21)

Course-3: INDIAN GOVERNMENT AND POLITICS

Course Code	POLT301C	Course Delivery Method	Class Room
Credits	4	CIA Marks	30
No.of Lecture Hours/Week	5	Semester End Exam Marks	70
Total Number of Lecture Hours	60	Total Marks	100
Year of Introduction2020-2021	Year of offering 2021-2022	Year of Revision 2021-2022	Percentage of Revision 0%

Course Outcomes:

CO1: The students community has acquired knowledge of the making of the Indian Constitution and its philosophical background. L1

CO2: Information about the functionaries of the government both at the union and state level was acquainted by the student community.L1, L2

CO3:To Understand the legislative procedures which ensure the orderly conduct of business in our parliament and state legislative assemblies in **India.**

CO4: To understand know the Ministers, their role &responsibilities.L1,

CO5: To understand Judiciary of India.L1, L2

Learning Outcomes:

On successful completion of the course the students will be able to:

- Acquire knowledge about the historical background of Constitutional development in India, appreciate philosophical foundations and salient features of the Indian Constitution.

- Analyze the relationship between State and individual in terms of Fundamental Rights and Directive Principles of State Policy.
- Understand the composition and functioning of Union Government as well as State Government and finally
- Acquaint themselves with the judicial system of the country and its emerging trends such as judicial reforms.

UNIT-I :	SOCIAL AND IDEOLOGICAL BASE OF THE INDIAN CONSTITUTION	15 hrs
	1. Constitutional Development in India during British Rule-A Historical	
	2. Constituent Assembly-Nature, Composition, Socio-Economic,	
	Philosophical Dimensions and Salient Features of the Indian	

UNIT-II	INDIVIDUAL AND STATE	15 hrs
	1. . Fundamental Rights, Directive Principles of State Policy and Fundamental Duties-Differences between Fundamental Rights and Directive Principles of State Policy.	
	2. The ‘Doctrine of Basic Structure of the Constitution’ with reference to Judicial Interpretations and Socio-Political Realities.	

UNIT-III :	UNION EXECUTIVE	10 hrs
	1. President of India-Mode of Election, Powers and Functions.	
	2. Parliament-Composition, Powers and Functions, Legislative Committees, Prime Minister and Council of Ministers-Powers and	

UNIT-IV :	STATE EXECUTIVE	10 hrs
	1. Governor-Mode of Appointment, Powers and Functions.	
	2. Legislature-Composition, Powers and Functions, Chief Minister and	

UNIT-V :	THE INDIAN JUDICIARY	10 hrs
	1. Supreme Court-Composition and Appointments, Powers and	
	Functions or Jurisdiction of the Supreme Court, Judicial Review, Judicial	
	2. High Court-Composition, Powers and Functions, Debates on the	
	mode of appointment of Judges-National Judicial Appointments	

A.G &S.G SIDDHARTHA DEGREE COLLEGE OF ARTS & SCIENCE
[AUTONOMOUS] VUYYURU-521165

SEMESTER-III CODE-POLT301C ACADEMIC YEAR-2020-2021

PAPER TITLE:INDIAN GOVERNMENT AND POLITICS

Duration: 3 Hours Maximum Marks:70 Pass Marks:28

Section-A

Answer any **Two** of the following questions (2x5=10 Marks)

1. Explain the Indian Government act of 1935.
2. Describe the Fundamental duties of Indian citizens.
3. Discuss the various Legislative committees.
4. Judicial Review.

Section-B

Answer any **Four** of the following questions (4x15=60 Marks)

5. Explain the salient features of the Indian Constitution.
6. Explain the Fundamental Rights of the Constitution.
7. Explain the powers and Functions of the President of India.
8. Explain the powers and Functions of Chief Minister.
9. Describe the structure and Functions of Supreme Court of India.
10. Explain the powers and Functions of Prime Minister.
11. Explain the Directive Principles of the state policy in Indian Constitution.
12. Explain the powers and Functions of Governor.

**A.G. & S.G.SIDDHARTHA DEGREE COLLEGE OF ARTS &
SCIENCE (AUTONOMOUS), (2020-21) VUYYURU**
PAPER TITLE : PAPER-V (CORE): INDIAN POLITICAL THOUGHT

Course Code	POL501C	Course Delivery Method	Class Room
Credits	4	CIA Marks	30
No.of Lecture Hours/Week	5	Semester End Exam Marks	70
Total Number of Lecture Hours	60	Total Marks	100
Year of Introduction2020-2021	Year of offering 2021-2022	Year of Revision 2021-2022	Percentage of Revision 0%

Course outcomes :

CO1: *It helps* students discover the political philosophy that forms the basis of politics in the Indian Political Thought , to interpret the political philosophies of the Ancient Indian and Medieval philosophers in historical context as well as relate them to contemporary politics.

CO2: Origin of the knowledge in the Indian political thought.

CO3: To understand the political thoughts in medieval period and how it laid foundation to modern.

CO4: To demonstrate how government politics people by democracy and individual people.

CO5: To demonstrate individual freedom and Theory of sarvodaya.

Learning outcomes:

On successful completion of the course the students will be able to:

- Understand the fundamental course classical, Indian political phil, basic features of medieval political thought and shift from medieval to modern era.
- Understand the Gandhi and Political Theory and appreciate its implications on the perception of State in terms of its purposes and role.
- Acquaint with the Liberal and M.N Roy human radicalism and Jayaprakash Narayana Political Ideas

- critically analyze the evolution of Indian political thought.

Unit -I: **15Hrs**

1. Manu: Social laws ,dandaneethi
2. Kautilya : kingship, Mandala Theory, Saptanga Theory

UNIT – II **15HRS**

1. Gandhi:
 - a.Non-violence, Satyagraha.
 - b.Theory of Trusteeship.
2. JoythiRao Pule: - Social reform

UNIT – III **15HRS**

Nehru:

- a. Democratic Socialism.
- b.Non-Alignment

Ambedkar:

- a.Views on Indian Society.
- b.Social Movements.

UNIT – IV **15HRS**

M.N. Roy:

- Radical Humanism

Jaya Prakash Narayan:

- Total Revolution.
- Sarvodaya.

Text Books

1. “Rajaneethi Thatvavicharam”: A Text Book by Telugu Academy.

Reference books:

1. Pantham Thomas and Kenneth Deutsch(Ed)(1986)
Political thought in modern India, Sage, New Delhi
2. BidyutChakrabarthy and Rajendra Kumar Pandey (2009) modern Indian political thought, Sage, New Delhi
3. GurpreetMahajan (2013), India : Political ideas and making of a democratic discourse, zed book, London

4. ParthaChatterjee (1986) nationalist thought and the colonial world: A derivative disclosure, zed books, London
5. Bhikhu Parekh (1999) colonialism, tradition and reform,Sage,New Delhi
6. BhikhuParekh(1989) Gandhi's political philosophy ,Macmillan, London.

**AG & SG SIDDHARTHA DEGREE COLLEGE OF ARTS AND SCIENCE,
VUYYURU**

**(AN AUTONOMOUS COLLEGE IN THE JURISDICTION OF KRISHNA
UNIVERSITY, MACHILIPATNAM, A.P)**

POLITICAL SCIENCE	POL 501C	2020-21	III BA
-------------------	----------	---------	--------

EXAMINATION AT THE END OF FIFTH SEMESTER

SEMESTER – V

TIME: 3 HRS

PAPER – V

MAX. MARKS: 70

Model Paper

Indian Political Thought

Section – A

I. ANSWER any TWO OF THE FOLLOWING.

(2 × 5 = 10)

- 1) DANDA NEETHI.
- 2) write about Koutilya's Saptanga.
- 3) Explain Gandhi's Theory of Trusteeship
- 4) DR. AMBEDKAR'S ANNIHILATION OF CASTE.

Section – B

Answer any FOUR of the following.

(4 × 15 = 60)

- 5) Explain Manu's classification of Varna.
- 6) Explain the mandala theory of kautilya.
- 7) State and criticize Gandhi's satyagraha and non-violence.
- 8) Write an essay on social movements led by Dr. Ambedkar.
- 9) Write an essay on mahatma Jyothirao Phule
- 10) Discuss Jawaharlal Nehru's views on Democratic Socialism.
- 11) Briefly explain Jaya Prakash Narayan's total revolution
- 12) Write about M.N. Roy's radical humanism

A.G & S.G SIDDHARTHA DEGREE COLLEGE of Arts & Science

VUYYURU-521165

(An Autonomous college in the Jurisdiction of Krishna University, Machilipatnam)

Political science	POL501C	III B.A
--------------------------	----------------	----------------

Subject: Indian Political Thought

Semester-V

Paper-V

Guidelines to the paper setter

SECTION	Unit-I	Unit-II	Unit-III	Unit-IV
A 5 Marks Questions	2	1	1	
B 15 Marks Questions	2	2	2	2
Weight age	40	35	35	30

**A.G. & S.G.SIDDHARTHA DEGREE COLLEGE OF ARTS & SCIENCE
(AUTONOMOUS), (2020-21) VUYYURU**

PAPER TITLE : PAPER-VI (CORE): WESTERN POLITICAL THOUGHT

Course Code	POL502C	Course Delivery Method	Class Room
Credits	4	CIA Marks	30
No.of Lecture Hours/Week	5	Semester End Exam Marks	70
Total Number of Lecture Hours	60	Total Marks	100
Year of Introduction2020-2021	Year of offering 2021-2022	Year of Revision 2021-2022	Percentage of Revision 0%

Course outcomes :

CO1: It helps students discover the political philosophy that forms the basis of politics in the Western world, to interpret the political philosophies of the Greek, Roman , French, English and German philosophers in historical context as well as relate them to contemporary politics.

CO2: Origin of the knowledge in political thought.

CO3: To understand the political thoughts in medieval period and how it laid foundation to modern.

CO4: To demonstrate how government politics people by democracy and individual people.

CO5: To demonstrate individual freedom, surplus value, materialist.

Learning outcomes:

On successful completion of the course the students will be able to:

- Understand the fundamental contours classical, western political philosophy, basic features of medieval political thought and shift from medieval to modern era.
- Understand the Social Contract Theory and appreciate its implications on the perception of State in terms of its purposes and role.
- Acquaint with the Liberal and Marxist philosophy and analyze some trends in Western Political Thought.

- Critically analyse the evolution of western political thought.

Unit-I: Plato: 15Hrs
 a.Theory of Justice
 b. Education System
 c.Philosopher -King
 d.Theory of Communism

Unit-II: Aristotle: 15Hrs
 a. Ideal state
 b. Theory of Revolutions.
 c. Classification of governments

Unit-III: 15Hrs
 1. Machiavelli-political Ideas, Advice to the Prince
 2. Thomas Hobbes: Human nature, Social Contract, Sovereignty
 3. John Locke: Natural Rights and Social Contract,
 4. Rousseau: Social Contract and General Will

Unit-IV: 15Hrs
 1. **Hegel:** Civil Society, State
 2. **Karl Marx:** Surplus Value, History of Dialectical Materialism, State

Reference books:

1. ShefaliJha (2010) Western Political Thought from Plato to Karl Marx, Pearson, and New Delhi
2. Boucher D and Kelly P (Eds) (2009) Political Thinkers from Socrates to the Present, Oxford University press, oxford
3. Coleman J (2000) A History of Modern Political Thought: From Ancient Greece to early Christianity, Blackwell publishers, oxford
4. Macpherson C B (1962) The Political Theory of Possessiveness Individualism, Oxford University press, oxford
5. Hampsher-monk I (2001) A History of Modern Political Thought: Major Political Thinkers From Hobbers to Marx, Blackwell publishers, oxford

AG & SG SIDDHARTHA DEGREE COLLEGE OF ARTS AND SCIENCE, VUYYURU

**(AN AUTONOMOUS COLLEGE IN THE JURISDICTION OF KRISHNA
UNIVERSITY, MACHILIPATNAM, A.P)**

POLITICAL SCIENCE	POL 502C	2020-21	III BA
-------------------	----------	---------	--------

EXAMINATION AT THE END OF FIFTH SEMESTER

SEMESTER – V

TIME: 3 HRS PAPER

MAX. MARKS: 70

Model paper

Western political thought

Section – A

I. Answer any two of the following

(2 × 5 = 10)

- 1) Philosopher-king
- 2) What are the views of hobbes on human nature.
- 3) Theory of natural rights
- 4) Examine mark's views on class War

Section – B

II. Answer any Four of the following.

(4 × 15 = 60)

- 5) Explain the features of plato's education
- 6) Analyze aristotle's views on revolutions.
- 7) What are qualities of a Prince suggested by Machiavelli?
- 8) Social Contract Theory of Rousseau
- 9) Social Contract Theory of Hobbes
- 10) Explain Plato's Theory of Justice
- 11) Plato system of education
- 12) Karl Marx's Theory of Communism.

AG & SG SIDDHARTHA DEGREE COLLEGE of Arts & Science

VUYYURU-521165

(An Autonomous college in the Jurisdiction of Krishna University, Machilipatnam)

Political science	POL-502C	IIB.A
--------------------------	-----------------	--------------

Subject: western Political thought

Semester-V

Paper-VI

Guidelines to the paper setter

SECTION	Unit-I	Unit-II	Unit-III	Unit-IV
A 5 Marks Questions	1		2	1
B 10 Marks Questions	2	2	3	1
Weight age	35	30	55	20

Note: In view of vast syllabus more weightage given to **unit-III**

**Adusumilli Gopalakrishnaiah & Sugarcane Growers
Siddhartha Degree College of Arts & Science
(Autonomous)**

Vuyyuru-521 165, Krishna District, A.P.

--)00(--



Department of Economics

Minutes of the meeting of Board of Studies

29.10.2021

AG&SG SIDDHARTHA DEGREE COLLEGE OF ARTS and SCIENCE
(AUTONOMOUS) VUYYURU

ACEDAMIC YEAR - 2021 - 2022

Minutes of the meeting of the Board of Studies in Economics of AG & SG Siddhartha Degree College of Arts & Science, Vuyyuru, held at 11.00A.M ON 29 – 10 - 2021 In the Department of Economics.

Sri.N.Rama Rao , HOD, Economics has Presided over the BOS meeting

Members Present:

- | | | |
|-------------------------------|-----------------------------|--|
| 1) | Chairman | Head, Department of Economics
AG & SG S Degree College of Arts
& Science, Vuyyuru-521165 |
| (Sri.N.Rama Rao) | | |
| 2) | University
Nominee | Head Department of Economics
S.A.S. Government Degree College
Narayanapuram |
| (MrsG.NirmalaJyothi) | | |
| 3) | Academic Council
Nominee | Head, Department of Economics
SDMS Mahila Kalasala, Vijayawada |
| (D.Aruna) | | |
| 4)..... | Academic Council
Nominee | Lecturer in Economics ,
V.S.R.Government Degree College,
Movva. |
| (G.SureshBabu) | | |

AGENDA

1. To Review and recommend any changes in the syllabi , Model Question Papers and Guidelines of 1st, 3rd,and 5th Semesters of I, II and III Year B.A. Economics Papers for the Academic Year 2021-2022.

- 2.To Discuss and recommend the pattern of internal Assesment , Guidelines and Model Question Papers in 1st , 3rd and 5th Semesters of B.A Degree Economics papers for the Academic Year 2021-2022.

3. To Recommend the guidelines to be followed by the Question Paper Setters in Economics for the 1st, 3rd and 5th Semester-end exams.

4. To Recommend the teaching and evaluation methods to be followed under the Autonomous Status.

5. To Propose the panel of Question paper setters and Examiners.

6. To Suggest innovative methods of teaching.

- 7.Any other matter.

RESOLUTIONS:

- 1) It is resolved to continue the same syllabi under CBC System approved by the Academic council of 2020- 2021 for III Degree in V Semester Economics papers, of B.A Classes.

Resolved to follow the New Syllabus prescribed by APSHE in the I Semester of I Degree B.A from the Academic year 2020 – 2021 and in the III Semester of II Degree B.A from the Academic year 2021 – 2022.

- 2) Out of maximum 100 marks in each paper 30 marks shall be allocated for Internal Assessments regarding III and V Semesters.

A) To implement 30 marks for internal assessment and 70 marks for External Assessment from the academic year 2019-20 and that is also implemented to the III and V Semesters from 2020-21 Academic year and 2021 – 2022 Academic year also.

B) Out of these 30 marks, 20 marks are allocated for internal tests, 5 marks are allocated for assignment for III and V Semesters. The two tests will be conducted and average of these two tests shall be deemed as the marks obtained by a student, and remaining 5 marks are allocated for attendance.

- 3) **Out of maximum 100 marks 25 Marks shall be allocated for Internal Assessments Regarding the I Semester from the Academic year 2021 – 2022.**

A) To implement 25 Marks for Internal Assessments and 75 Marks for External Assessment regarding the I Semester from the Academic year 2021 – 2022.

B) Out of these 25 marks, 20 Marks are allocated for internal tests, 5 marks are Allocated for assignment/ attendance Regarding the I Semester from the Academic year 2021 – 2022.

- 4) Discussed and recommended the syllabi, Model question papers under CBC system and guidelines to be followed by the question paper setters of 1st semester of I, III and V semesters of B.A Classes for the Academic year 2021-2022.

- 4) To follow the teaching and evaluation methods, it is also resolved to use various other methods like Group discussions, Quiz, Organizing Seminars, Guest Lectures and

Workshops to upgrade the knowledge of the students and impart new skills of learning as frequently as possible.

- 5) Resolved to authorize the chairman of Board of studies to suggest the panel of paper setters and Examiners to the controller of Examinations as for the requirement.

- 7) The APSHE NewSKILL DEVELOPMENT COURSE Financial Markets is Introduced in the III Semester for II B.A Students from the Academic year 2021-2022. No Internal Examinations for this Paper. Only External Examination will be conducted for 50 Marks.

It is resolved to follow further changes if any in the syllabus by the competent Authority.

Chairman

SEMESTER-I

Course Code	Title of the Course	Instruction Hours per week	Credits	Evaluation		
				CIA MARKS	SEE	
					MARKS	DURATION
ECO-101	MICRO ECONOMIC ANALYSIS	5	4	25	75	3Hrs

SEMESTER-III

Course Code	Title of the Course	Instruction Hours per week	Credits	Evaluation		
				CIA MARKS	SEE	
					MARKS	DURATION
ECO-301	DEVELOPMENT ECONOMICS	5	4	30	70	3Hrs
FM-301	FINANCIAL MARKETS	2	2	Nil	50	2 Hrs

SEMESTER-V

Course Code	Title of the Course	Instruction Hours per week	Credits	Evaluation		
				CIA MARKS	SEE	
					MARKS	DURATION
ECO-501	ECONOMIC DEVELOPMENT AND INDIAN ECONOMY	5	4	30	70	3Hrs
ECO-502	INDIAN AND ANDHRA PRADESH ECONOMY	5	4	30	70	3Hrs

PROGRAMME OUT COMES

1. able to understand basic concepts of economics.
2. able to analyze economic behavior in practice.
3. To understand the economic way of thinking.
4. ability to analyze historical and current events from an economic perspective.
5. The ability to write clearly expressing an economic point of view.
6. Be exposed to alternative approaches to economic problems through exposure of course work in allied fields.
7. To create students ability to suggest of the various economic problems.

Program me specific out comes

After completion of BA Degree program with Economics combination the Graduates will be able to

PSO1- To understand the Basics of Economics and Economic Activities of students and public in our society.

PSO2- To create an awareness on different activities like production, distribution, marketing etc..

PSO3- To analyse the price determination theories to the entrepreneurs, business activities.

PSO4- To prepare the students for future studies employability and responsible citizenship.



A. G & S.G. SIDDHARTHA DEGREE COLLEGE OF ARTS & SCIENCE

Vuyyuru-521165.

NAAC reaccruited at 'A' level

Autonomous -ISO 9001 – 2015 Certified

TITLE OF THE PAPER:MICRO ECONOMIC ANALYSIS

Semester: I

Course Code	ECO-101	Course Delivery Method	Class Room / Blended Mode - Both
Credits	4	CIA Marks	25
No. of Lecture Hours / Week	5	Semester End Exam Marks	75
Total Number of Lecture Hours	60	Total Marks	100
Year of Introduction:	Year of Offering: 2021 - 22	Year of Revision: ----	Percentage of Revision: 0%
CLASS:	1.B.A		

COURSE OUTCOMES:

At the end of the course, the student will be able to:

CO1-Able to understand the Definitions of Economics ,differences between micro economics and Macro Economics

CO2- Able to understand the factors determining demand Law of Demand - reasons and exceptions-Elasticity of Demand and Indifference Curve analysis

CO3- Able to understand the various Cost curves and Revenue Curves Concepts of Production function, Law of variable propositions, law of Return to Scale.

CO4- Able to understand the Different Markets and its Equilibrium

CO5- Able to understand the Different theories of Rent, Profit and interest .

Learning Objectives:

- 1.To understand the Definitions of Economics, differences between micro economics and Macro Economics
- 2.To understand the factorsdetermining demand Law of Demand - reasons and Exceptions-Elasticity of Demand and Indifference Curve analysis
- 3.To understand the various Cost curves and Revenue Curves Concepts of Production function, Law of variable proportions , law of Return to Scale.
- 4.To understand the Different Markets and its Equilibrium
5. To understand the Different theories of Rent, Profit and Interest

**MICRO ECONOMIC ANALYSIS
SYLLABUS**

Unit-I Economic Analysis and Methodology (08 HRS)

- 1.1 Definitions of Economics
 - 1.1.1 Wealth Definition
 - 1.1.2 Welfare Definition
 - 1.1.3 Scarcity Definition
 - 1.1.4 Growth Oriented Dynamic Definition-
- 1.2 Methodology in Economics
 - 1.2.1 Micro and Macro Economics-
 - 1.2.2 Deductive and Inductive Methods
 - 1.2.3 Production Possibility Curve (PPC)

Unit-II THEORY OF CONSUMPTION (12 HRS)

- 2.1 Demand Analysis
 - 2.1.1 Concept & Factors Determining Demand
 - 2.1.2 Law of Demand and Exceptions
- 2.2 Elasticity of Demand
 - 2.2.1 Types of Price Elasticity of Demand
 - 2.2.2 Methods to measure Price Elasticity of Demand
- 2.3 Indifference Curve Analysis
 - 2.3.1 Indifference Schedule & Indifference map
 - 2.3.2 Marginal Rate of Substitution
 - 2.3.3 Properties of Indifference curves
 - 2.3.4 Budget line & Consumers Equilibrium through Indifference Curve
 - 2.3.5 Consumer's Surplus through Indifference Curve Analysis

Unit-III THEORY OF PRODUCTION (15 HRS)

- 3.1 Concept of Production Function
 - 3.1.1 Cobb-Douglas Production Function
 - 3.1.2 The law of variable proportions
 - 3.1.3 The law of Returns to Scale
 - 3.1.4 Economies of large Scale Production
- 3.2 Concepts of cost
 - 3.2.1 Short run Cost Curves
- 3.3 Law of supply
- 3.4 Revenue Concepts (T.R., A.R. & M.R.)
 - 3.4.1 Relationship between AR, MR & E.D
 - 3.4.2 Cost minimization
 - 3.4.3 Profit Maximization

Unit-IV THEORY OF EXCHANGE (10 HRS)

- 4.1 Classification of Markets
- 4.2 Features of Perfect Market Conditions

- 4.3 Price Determination under Perfect Competition Market
- 4.4 Features of Monopoly Market
- 4.5 Features of Monopolistic Competition Market
- 4.6 Features of Oligopoly Market
- 4.7 Kinky Demand Curve Analysis

Unit-V THEORY OF DISTRIBUTION

(15 HRS)

- 5.1 Concepts of Functional and Personal Distribution
- 5.2 Marginal Productivity Theory of Distribution
- 5.3 Theories of Rent
 - 5.3.1 Ricardian Theory of Rent
 - 5.3.2 Marshall's Economic rent
- 5.4 Theories of Wage
 - 5.4.1 Standard of Living Theory of wages
 - 5.4.2 Modern Theory of wages
- 5.5 Theories of Interest
 - 5.5.1 Classical Theory of Interest
 - 5.5.2 Loanable Funds Theory of Interest
 - 5.5.3 Keynes Liquidity Preference Theory of Interest
- 5.6 Theories of Profit
 - 5.6.1 Risk Theory of Profit
 - 5.6.2 Uncertainty Theory of Profit
 - 5.6.3 Dynamic Theory of Profit
 - 5.6.4 Innovation Theory of Profit

Text Book : Telugu Academy Publications

Reference Books :

- H.L. Ahuja – Advanced Economic Theory - S.Chand& Company Publishers
- H.S. Agarwal – Principles of Economics
- M.L. Seth – Micro Economics, Lakshmi NarayanaAgarwal Publishers
- A.W. Stonier & D.C Hague – A Text Book of Economic Theory, E.L.B.S
- Koutsoyiannis : Modern Micro Economics, Mc. Millan

Co-curricular activities and Assessment Methods:

1. Continuous Evaluation: Monitoring the progress of student's learning
2. Class Tests, Assignments and Quizzes
3. Presentations, Projects and Assignments and Group Discussions: Enhances critical thinking skills and personality
4. Semester- end Examination: critical indicator of student's learning and teaching methods adopted by teachers throughout the semester

A.G. & S.G.SIDDHARTHA DEGREE COLLEGE OF ARTS & SCIENCE
(AUTONOMOUS), (2021 - 2022) VUYYURU

SEMESTER- I

MODEL PAPER

Section-A

I. Answer any Five of the Following:

5X5=25M

1. Dynamic Theory Profit- L2,CO5
2. Classification of Markets- L2,CO4
3. Relationship between Average Cost and Marginal Cost-L3,CO3
4. Features of Monopoly Market- L1,CO4
5. Subsistence theory of Wages-L2,CO5
6. Explain the law of supply-L3,CO3
7. Explain the concept of Economic Rent?- L3,CO5
8. Explain Micro Economic analysis -L3,CO1

Section-B

Answer of the Following:

5X10=50M

- 9.(A) Discuss the Concept of Risk bearing theory of Profits ?-L3,CO5
(or)
B) Critically examine the Keynes Liquidity Preference theory of interest- L3,CO5
10. (A) Define Micro and Macro Economics. Explain their Importance-L1,CO1
(or)
(B) Examine the Modern theory of wages ?-L3,CO5
11. (A) Critically examine the Marginal Productivity theory of distribution?-L3,CO5
(or)
(B) Graphically explain the law of variable proportions-L3, CO3
12. (A) Explain the Price determination of under Perfect Competition?- L3,CO4
(or)
(B) Examine the Scarcity definition -L2,CO1
13. (A) Explain consumer equilibrium with the help of indifference curve analysis-
L3,CO2
(or)
(B) Analyse the features of Oligopoly market and write about Kinky Demand
Curve ?-L1,CO4



A. G & S.G. SIDDHARTHA DEGREE COLLEGE OF ARTS & SCIENCE

Vuyyuru-521165.

NAAC reaccredited at 'A' level

Autonomous -ISO 9001 – 2015 Certified

TITLE OF THE PAPER:DEVELOPMENT ECONOMICS

Semester: III

Course Code	ECO-301	Course Delivery Method	Class Room / Blended Mode - Both
Credits	4	CIA Marks	25
No. of Lecture Hours / Week	5	Semester End Exam Marks	75
Total Number of Lecture Hours	60	Total Marks	100
Year of Introduction:	Year of Offering: 2021 - 22	Year of Revision: ----	Percentage of Revision: 0%
CLASS:	II.B.A		

LEARNING OUTCOMES FOR THE COURSE :

At the end of the course, the student is expected to demonstrate the following cognitive abilities and psychomotor skills.

1.Remembers and states in a systematic way (Knowledge)

Various concepts and definitions and indicators relating to economic growth and Development including recent developments

2. Explains (understanding)

a. Distinction between growth and development with examples

c. Characteristics of developing and developing economies and distinction between the two

d. factors contributing to development, Choice of Techniques and a few important models and strategies of growth

3. Critically examines using data and figures (analysis and evaluation)

- a. the theoretical aspects of a few models and strategies of economic growth
- b. role and importance of various financial and other institutions in the context of India's economic development

4. Draws critical diagrams and graphs.

- a. to explain the models and strategies
- b. to highlight empirical evidences to support the strategies

DEVELOPMENT ECONOMICS

Syllabus

Module - 1: Economic Growth and Development (15 HRS)

Economic Development as a Branch of Study of Economics – Scope and Importance - Distinction between Economic Growth and Economic Development -Measures of Economic Development and their limitations - Relevance of Herd (Group) Immunity in the context of COVID 19 - three core values of economic development : Sustainability, Self-esteem and Freedom – Economy and Environment : Concepts of sustainable development and inclusive growth

Module -2: Modern Economic Growth (15 HRS)

Characteristics of Underdeveloped Countries - World Bank and IMF Classification of countries - Modern economic growth – Kuznets’ Six Characteristics -Obstacles to economic development - Vicious Circle of Poverty and cumulative causation -Factors of economic growth: Economic and Non-economic - Capital Formation – Foreign and Domestic capital, Debt and Disinvestment.

Module-3: Theories of Development and Underdevelopment (10 HRS)

Classical Theory: Adam Smith, Ricardo and Malthus -Marxian Theory - Schumpeter Theory - Rostow’s Stages of Economic Growth -Harrod-Domar two sector model -Solow’s Model and Robinson’s Golden Age

Module – 4: Strategies of Economic Development (10 HRS)

Strategies of Economic Development – Big Push -Balanced Growth -Unbalanced Growth - Mahalanobis Model - Agriculture vs Industry -Capital Intensive Technology vs Labour Intensive Technology -Role of Infrastructure in Economic Development

Module - 5: Institutions and Economic Development (10 HRS)

Role of State in Economic Development -Role of Markets - Market Failure and Regulation by State -Public sector vs Private sector -Economic Planning – concept, objectives and types - NITIAYog - Economic Federalism -Financial Institutions and Economic Development – Role of International Institutions – IDBI, ADB, IMF – Foreign Trade – FIIs and FDIs

Reference Books:

1. Dhingra, I.C., Indian Economy, Sultan Chand, New Delhi, 2014.
2. Gaurav Datt and Ashwani Mahajan, Datt and Sundharam's Indian Economy, S.Chand & Co., 2016.
3. G. M. Meier, Leading Issues in Economic Development, Oxford University Press, New York, 3/e.
4. M. P. Todaro and Stephen C. Smith, Economic Development, 10/e, Indian Edition Published by Dorling Kindersley India Pvt. Ltd. 2012.
5. M. L. Koncham, Economic development and planning, Himalaya publications
6. S.K.Misra & V.K.Puri, Indian Economy, Himalaya Publishing House, 2015.
7. R.S.Rao, V.Hanumantha Rao & N.Venu Gopal (Ed.), Fifty Years of Andhra Pradesh (1956-2006), Centre for Documentation, Research and Communications, Hyderabad, 2007.
8. G. Omkarnath, Economics - A Primer for India - Orient Blackswan, 2012.
9. Economic development and growth, Spectrum Publishing House, Hyderabad, 2016

Recommended Co-curricular Activities:

1. Assignments on the models and the strategies of economic development adopted in Indian economy
2. Student Seminar on development oriented themes relating to Indian economy
3. Quiz to test critical understanding of the fundamental concepts of growth and development and the growth models and strategies
4. Group discussion on the effectiveness of the roles played by various institutions in India's economic development
5. Group project work to examine specific aspects of growth like poverty, unemployment, human development, gender development as Indian experience in the context of economic development preferably at the state and local level
6. Poster presentation

**A.G. & S.G.SIDDHARTHA DEGREE COLLEGE OF ARTS & SCIENCE
(AUTONOMOUS), (2021 - 2022) VUYYURU**

SEMESTER – III	COURSE CODE:ECO - 301
PAPER TITLE :DEVELOPMENT ECONOMICS	

Duration : 3Hours

Maximum marks : 70

Pass marks : 28

SECTION - A

Answer any **TWO** of the following questions

(2x5=10 Marks)

1. Features of Economic Development.
2. World Bank's country classification systems.
3. Labour Intensive Technology.
4. What are the different types of Plans.

SECTION – B

Answer any **FOUR** of the following questions.

(4X15=60 Marks)

5. What is Economic Growth and What is Economic Development? Differentiate between Economic Growth and Economic Development.
6. Write about the Relevance of Herd (Group) Immunity in the context of Covid– 19.
7. Explain the features of Developing Countries with special reference to India.
8. Write about the vicious circle of poverty.
9. Explain about Schumpeter's Theory of Economic Development.
10. Write about the Role of Infrastructure in Economic Development.
11. What are the main objectives of planning in India?
12. Write about NITI AYOGE?

**A.G. & S.G.SIDDHARTHA DEGREE COLLEGE OF ARTS & SCIENCE
(AUTONOMOUS), (2021 - 2022) VUYYURU**

The Guidelines to be followed by the question paper setters in **DEVELOPMENT ECONOMICS** for the III Semester – End Examinations (2021 - 2022)

PAPER TITLE : DEVELOPMENT ECONOMICS

Paper- III Semester – III Maximum marks : 70 Duration : 3Hours

Weightage for the question paper

Syllabus	Section-A (Short answer questions)	Section-B (Essay questions)
Unit-1 (35Marks)	1	2
Unit-2 (35Marks)	1	2
Unit-3 (15Marks)	-----	1
Unit-4 (20Marks)	1	1
Unit-5 (35Marks)	1	2
TOTAL 140	20	120

1. Each question carries 5 marks in Section-A
2. Each Essay question carries 15 marks in Section –B
3. The Question papers setters are requested to cover all the topics in the syllabus stipulated as per the weightage given by us.



A. G & S.G. SIDDHARTHA DEGREE COLLEGE OF ARTS & SCIENCE

Vuyyuru-521165.

NAAC reaccredited at 'A' level

Autonomous -ISO 9001 – 2015 Certified

TITLE OF THE PAPER: ECONOMIC DEVELOPMENT AND INDIAN ECONOMY

Semester: V

Course Code	ECO-501	Course Delivery Method	Class Room / Blended Mode - Both
Credits	4	CIA Marks	25
No. of Lecture Hours / Week	5	Semester End Exam Marks	75
Total Number of Lecture Hours	60	Total Marks	100
Year of Introduction:	Year of Offering: 2021 - 22	Year of Revision: ----	Percentage of Revision: 0%
CLASS:	III.B.A		

LEARNING OUTCOMES FOR THE COURSE

- 1.To able to understand economic growth and development and different growth models .Horrod Domor, Adamsmith Rostow theory, Karal Marks etc., able to understand some growth models
- 2.Development theories: theories of persistence of under development –stratagies for development balanced and unbalanced growth strategy, development with unlimited supply of labour (lewis).
- 3.Economics of natural resourses and sustainable development :- this course will help in understanding that types of natural resourses and their exploitation
4. Understand the population and economic growth understand basic futures of Indian economy .trend and composition of national income and for capital income ,occupational distribution, basic demography features.
5. Study of poverty, inequality and unemployment; conceptual and measurement issues –the Indian situation.to analyze new economic policies (privatization liberalization and globalization in India.

ECONOMIC DEVELOPMENT AND INDIAN ECONOMY SYLLABUS

Module – 1 (15 HRS)

Concept of Economic Growth - Distinction between economic growth and development - Measurement of economic development -Theories of Economic Growth:
Adam Smith, Rostow, Karl Marx and Harrod&Domar Models.

Module – 2 (10 HRS)

Sustainable development - Balanced and unbalanced growth-choice of techniques
Labour intensive and capital intensive methods.

Module – 3 (10 HRS)

Basic features of the Indian Economy - Natural Resources - Important
Demographic features- Concept of Population Dividend - Population Policy.

Module – 4 (15 HRS)

National Income in India - trends and composition-poverty, inequalities and
Unemployment - Measures taken by the Government. - MGNREGS

Module – 5 (10 HRS)

Economic reforms - liberalization, privatization and globalisation - concept of
inclusive growth.

REFERENCES:

1. Dhingra, I.C - "Indian Economy", Sultan Chand, 2014.
2. RuddarDutt and K.P.M. Sundaram - "Indian Economy", S.Chand& Co., 2015.
3. G.M.Meier -"Leading Issues in Economic Development", Oxford University Press, New York,.
4. M.P.Todaro - "Economic Development", Longman, London 6/e, 1996.
5. Reserve Bank of India - Hand book of Statistics on Indian Economy (Latest).
6. S.K.Misra&V,K,Puri - "Indian Economy", Himalaya Publishing House, 2015.
7. R.S.Rao, V.HanumanthaRao&N.VenuGopal (Ed) - Fifty Years of Andhra Pradesh (1956-2006), Centre for Documentation, Research and Communications, Hyderabad, 2007.
8. G.Omkarnath - Economics - A Primer for India - Orient Blackswan, 2012.
9. Benjamin Higgins - Economic Development
10. Telugu Academy Publications.
11. Dr. Ch.S.G.K. Murthy, Indian Economy - Gitam University

**A.G. & S.G.SIDDHARTHA DEGREE COLLEGE OF ARTS & SCIENCE
(AUTONOMOUS), (2021 - 2022) VUYYURU**

SEMESTER – V	COURSE CODE:ECO-501
PAPER TITLE : ECONOMIC DEVELOPMENT AND INDIAN ECONOMY	

Duration : 3Hours

Maximum marks : 70

Pass marks : 28

SECTION - A

Answer any **TWO** of the following questions

(2x5=10 Marks)

1. Labour intensive techniques
2. Population Dividend
3. Poverty.
4. Globalisation.

SECTION – B

Answer any **FOUR** of the following questions

(4X15=60 Marks)

5. Critically Examine the Recordian theory of Growth.
6. Explain the concepts of Economic Growth and Economic Development and its differences
7. Critically Examine the Balanced Growth theory.
8. What are the Basic features of Indian Economy.
9. Explain the causes of population explosion in India.
10. Explain the composition and trends in India's National Income.
11. What is poverty? Mention the measures taken by the Government.
12. Explain the Liberalisation policy in India.

**A.G. & S.G.SIDDHARTHA DEGREE COLLEGE OF ARTS & SCIENCE
(AUTONOMOUS), (2021 - 2022) VUYYURU**

The Guidelines to be followed by the question paper setters in **ECONOMIC DEVELOPMENT AND INDIAN ECONOMY** for the V Semester – End Examinations (2020 - 2021)

PAPER TITLE :ECONOMIC DEVELOPMENT AND INDIAN ECONOMY

Paper- V Semester – V Maximum marks : 70 Duration : 3Hours

Weightage for the question paper

Syllabus	Section-A (Short answer questions)	Section-B (Essay questions)
Unit-1 (30Marks)	-----	2
Unit-2 (20Marks)	1	1
Unit-3 (35Marks)	1	2
Unit-4 (35Marks)	1	2
Unit-5 (20Marks)	1	1
TOTAL 140	20	120

1.Each question carries 5 marks in Section-A

2.Each Essay question carries 15 marks in Section –B

3. The Question papers setters are requested to cover all the topics in the syllabus stipulated as per the weightage given by us.



A. G & S.G. SIDDHARTHA DEGREE COLLEGE OF ARTS & SCIENCE

Vuyyuru-521165.

NAAC reaccruited at 'A' level

Autonomous -ISO 9001 – 2015 Certified

TITLE OF THE PAPER:INDIAN AND ANDHRAPRADESH ECONOMY

Semester: V

Course Code	ECO-502	Course Delivery Method	Class Room / Blended Mode - Both
Credits	4	CIA Marks	25
No. of Lecture Hours / Week	5	Semester End Exam Marks	75
Total Number of Lecture Hours	60	Total Marks	100
Year of Introduction:	Year of Offering: 2021 - 22	Year of Revision: ----	Percentage of Revision: 0%
CLASS:	III.B.A		

LEARNING OUTCOMES FOR THE COURSE:

- 1.Upon successful completion of this course , students should have to acquire knowledge regarding agriculture sector in India ,its trends and productivity
2. to make the students to understand about Indian industry.
- 3.to understand foreign direct investment and service sector in India they will be identifying the various objectives of planning in India and its achievements.
- 4.To make students to understand about Andhra Pradesh economy and its progress

Indian and Andhra Pradesh Economy

Syllabus

Module – 1 (15 HRS)

Indian Agriculture - Importance of Agriculture in India - Agrarian structure and relations- Factors determining Productivity- Agricultural Infrastructure - Rural credit - Micro Finance - Self Help Groups (SHGs) - Agricultural Price policy- concept of Crop Insurance - Food Security.

Module – 2 (15 HRS)

Structure and growth of Indian Industry - Industrial policies of 1956 & 1991 Meaning of Micro small and Medium Enterprises (MSMEs)- Problems and Prospects of small scale Industries in India.

Module – 3 (10 HRS)

Disinvestment in India - FEMA - Foreign direct investment - Services Sector in India – Reforms in Banking and Insurance -, IT, Education and Health.

Module – 4 (10 HRS)

Planning in India Economy - Objectives of Five year plans - Review of Five year Plans - Current Five year plan- NITI Aayog

Module – 5 (HRS)

Andhra Pradesh Economy - Population - GSDP - Sector Contribution and trends - IT – Small Scale Industry - SEZs.

REFERENCES:

1. Dhingra, I.C - "Indian Economy", Sultan Chand, 2014.
2. RuddarDutt and K.P.M. Sundaram - "Indian Economy", S.Chand & Co., 2015.
3. G.M.Meier - "Leading Issues in Economic Development", Oxford University Press, New York, 3/e.
4. M.P.Todaro - "Economic Development", Longman, London 6/e, 1996.
5. Reserve Bank of India - Hand book of Statistics on Indian Economy (Latest).
6. S.K.Misra & V.K,Puri - "Indian Economy", Himalaya Publishing House, 2015.
7. R.S.Rao, V.HanumanthaRao & N.VenuGopal (Ed) - Fifty Years of Andhra Pradesh (1956-2006), Centre for Documentation, Research and Communications, Hyderabad, 2007.
8. G.Omkarnath - Economics - A Primer for India - Orient Blackswan, 2012.
9. Telugu Academy Publications.
10. Dr.Ch.S.G.K.Murthy, Indian Economy - Gitam University.

A.G. & S.G.SIDDHARTHA DEGREE COLLEGE OF ARTS & SCIENCE
(AUTONOMOUS), (2021 - 2022) VUYYURU

SEMESTER – V	COURSE CODE:ECO-502
PAPER TITLE : Indian and Andhra Pradesh Economy	

Duration : 3Hours

Maximum marks : 70

Pass marks : 28

SECTION - A

Answer any **TWO** of the following questions

(2x5=10 Marks)

1. Industrial policy 1956.
2. FEMA
3. NeethiAyog .
4. SEZs (Special Economic Zones).

SECTION – B

Answer any **FOUR** of the following questions

(4X15=60 Marks)

5. Explain the Importance of Agriculture sector in India.
6. What is Green Revolution ? Explain the causes and Benefits of Green Revolution.
7. State the 1991 Industrial Resolution policy.
8. Explain the problems and remedies of small and cottage Industries in India.
9. Review the Disinvestment in India.
10. Explain the Foreign Direct Investment in India .
11. Review the performance of Five year plan's in India.
12. Explain the changes in the shares of various sectors in Gross Domestic Product in Andhrapradesh State.

A.G. & S.G.SIDDHARTHA DEGREE COLLEGE OF ARTS & SCIENCE
(AUTONOMOUS), (2021 - 2022) VUYYURU

The Guidelines to be followed by the question paper setters in **Indian and Andhra Pradesh Economy** for the V Semester – End Examinations (2020 - 2021)

PAPER TITLE : Indian and Andhra Pradesh Economy

Paper- V Semester – V Maximum marks : 70 Duration : 3Hours

Weightage for the question paper

Syllabus	Section-A (Short answer questions)	Section-B (Essay questions)
Unit-1 (30Marks)	-----	2
Unit-2 (35Marks)	1	2
Unit-3 (35Marks)	1	2
Unit-4 (20Marks)	1	1
Unit-5 (20Marks)	1	1

Total 140

20

120

- 1.Each question carries 5 marks in Section-A
- 2.Each Essay question carries 15 marks in Section –B
3. The Question papers setters are requested to cover all the topics in the syllabus stipulated as per the weightage given by us

AG & SG SIDDHARTHA DEGREE COLLEGE OF ARTS & SCIENCE VUYYURU

(AUTONOMOUS)

(MANAGED BY SIDDHARTHA ACADEMY OF GENERAL & TECHNICAL EDUCATION VIJAYAWADA)



Department of Commerce

Minutes of the meeting of Board of Studies

3-11-2021

**Minutes of the meeting of Board of studies in Commerce for the Autonomous courses of
AG & SG Siddhartha Degree College of Arts & Science, Vuyyuru, held at
10.30 A.M on 3-11-2021**

N.Vasanatha Rao* ... *Presiding

Members Present:

- 1)..... Chairman Head, Department of Commerce
(*N.Vasanatha Rao*) AG & SG S Degree College of Arts & Science
Vuyyuru
- 2)..... University Nominee
(*Dr.N.A Francis Xavier*) Head, Department of Commerce
Andhra Loyola College.
Vijayawada (9440524321)
nafrancisxavier@gmail.com
- 3)..... Subject Expert
(*Dr.K.Venkateswarlu,*) Lecturer in Commerce
V.S.R Govt. Degree & P.G College
Movva (9848341412)
gdcjkc.movva@gmail.com
- 4)..... Subject Expert
(*K.Narayanarao*) Lecturer in Commerce
P.B.Siddhartha College of arts and Science
Vijayawada. (9885038196)
hodcommerce@pbsiddhartha.ac.in
- 5)..... Member
(*Sri V.Punnarao*) General Manager
K.C.P & IC Ltd
Vuyyuru.
- 6)..... Member
(*Sri V.Balaji*) Chartered Accountant
Managing Partner
Balaji V & Co (9052190007)
Vuyyuru (cabalajinco@gmail.com)
- 7)..... Member
(*Sri V.GopiChand*) Lecturer in Commerce
AG & SG S Degree College of Arts & Science
Vuyyuru
- 8)..... Member
(*Sri K.SekharBabu*) Lecturer in Commerce
AG & SG S Degree College of Arts & Science
Vuyyuru
- 9)..... Member
(*Ms A.N.L Manohari*) Lecturer in Commerce
AG & SG S Degree College of Arts & Science
Vuyyuru

Minutes of the meeting of Board of studies in Commerce for the Autonomous courses of
AG & SG Siddhartha Degree College of Arts & Science, Vuyyuru, held at
10.30 A.M on 3-11-2021

N.Vasanatha Rao ... Presiding

Members Present:

- 1)  Chairman Head, Department of Commerce
(N.Vasanatha Rao) AG & SG S Degree College of Arts & Science
Vuyyuru
- 2) University Nominee
(Dr.N.A Francis Xavier) Head, Department of Commerce
Andhra Loyola College.
Vijayawada (9440524321)
nafrancisxavier@gmail.com
- 3)  Subject Expert Lecturer in Commerce
(Dr.K.Venkateswarlu,) V.S.R Govt. Degree & P.G College
Movva (9848341412)
gdcjkc.movva@gmail.com
- 4)  Subject Expert Lecturer in Commerce
(K.Narayanarao) P.B.Siddhartha College of arts and Science
Vijayawada. (9885038196)
hodcommerce@pbsiddhartha.ac.in
- 5) Member General Manager
(Sri V.Punnarao) K.C.P & IC Ltd
Vuyyuru.
- 6) Member Chartered Accountant
(Sri V.Balaji) Managing Partner
Balaji V & Co (9052190007)
Vuyyuru (cabalajinco@gmail.com)
- 7)  Member Lecturer in Commerce
(Sri V.GopiChand) AG & SG S Degree College of Arts & Science
Vuyyuru
- 8)  Member Lecturer in Commerce
(Sri K.SekharBabu) AG & SG S Degree College of Arts & Science
Vuyyuru
- 9)  Member Lecturer in Commerce
(Ms A.N.L Manohari) AG & SG S Degree College of Arts & Science
Vuyyuru

Agenda of B.O.S Meeting:

1. To discuss and recommend the Syllabi, Model Question Papers and Guidelines to be followed by question paper setters in Commerce for the 1st Semester as per the guidelines and instruction under CBCS prescribed by APSCHE for the Academic Year 2021-22.
2. To discuss and recommend the Syllabi, Model Question Papers and Guidelines to be followed by question paper setters in Commerce for the 3rd Semester as per the guidelines and instructions under CBCS prescribed by APSCHE for the Academic Year 2021-2022.
3. To discuss and recommend the Syllabi, Model Question Papers and Guidelines to be followed by question paper setters in Commerce for the 5th Semester as per the guidelines and instructions under CBCS prescribed by Krishna University for the Academic Year 2021-2022.
4. To recommend the Blue print of I, III & V Semesters of B.Com (General & Computers) for the Academic Year 2021-2022.
5. To recommend the Teaching and Evaluation methods to be followed under CBCS
6. Any other suggestions regarding Certificate Course, Seminars, Workshops, Guest Lectures to be organized.
7. Any other matter.

RESOLUTIONS

1. Discussed and recommended the syllabi, Model Question Papers and Guidelines for Question paper setters in commerce for the 1st Semester of **I B.Com.,(General& Computer & e-Commerce)** for the Academic year 2021-2022. Prescribed by APSCHE
2. Discussed and recommended the syllabi, Model Question Papers and Guidelines for question paper setters in Commerce for the 3rd Semester of **II B.Com.,(General& Computer)** for the Academic year2021-2022.prescribed by APSCHE
3. Discussed and recommended that no changes are required in syllabi, but some minor changes are required in Model Question Papers and Guidelines for question paper setters in Commerce for the 5th Semester of **III B.Com., (general & computer)** for the Academic year 2021-2022.
4. It is resolved to continue the same blue prints of III. & V Semesters of Degree B.Com (**general & computer**) for the Academic year 2021-2022.
5. It is resolved to continue following Teaching and Evaluation methods for Academic year 2021-2022.

Teaching methods:

Besides the conventional methods of teaching, we use modern technology i.e. using of LCD projector, display on U boards etc, for better understanding of concepts.

Evaluation of a student is done by the following procedure:

Internal Assessment (IA) I B.Com (General ,Computers & e-Commerce)

- Out of maximum 100 marks in each paper 25 marks shall be allocated for internal assessment for I.B.Com and (General ,Computers & e-Commerce). Out of these 25 marks, 20 Marks are allocated for announced tests (i.e. IA-1 & IA-2). Two announced tests will be conducted and average of these two tests shall be deemed as the marks obtained by the student, and remaining 5 marks are allocated for the assignment. There is no minimum passing for IA.

Internal Assessment (IA) II & III B.Com (General & Computers)

- Out of maximum 100 marks in each paper 30 marks shall be allocated for internal assessment for II & III.B.Com (General & Computers). Out of these 30 marks, 20 Marks are allocated for announced tests (i.e. IA-1 & IA-2). Two announced tests will be conducted and average of these two tests shall be deemed as the marks obtained by the student, 5 marks allocated on the basis of candidate's percentage of attendance and remaining 5 marks are allocated for the assignment. There is no minimum passing for IA.

Semester Examinations (SE)

- The Semester Examinations will be in the form of a comprehensive examination covering the entire syllabus in each subject. It will be of 3 hours duration, with maximum 70 marks, irrespective of the number of credits allotted to it.
 - Even though the candidate is absent for two IA exams/obtained zero marks, the external marks are considered (if he/she gets 40/70) and the result shall be declared as 'PASS'
 - The pass mark shall be 30 out of 75 in the Semester end examination for I B.Com (General ,Computers & e-Commerce)
 - The pass mark shall be 28 out of 70 in the Semester end examination for II & III.B.Com and (General & Computers)
 - The maximum marks for each Paper shall be 100.(Internal 30 + External 70)
6. Discussed and recommended to organize certificate course online/offline, seminars, Guest lectures, Online Examinations and Workshops to upgrade the knowledge of students for Competitive Examinations for the approval of the Academic Council.
 7. It is resolved to follow further changes if any in the Syllabus by the Competent Authority

Chairman

Programme Specific Outcomes (PSO)

PSO1. Getting the knowledge and the importance of accounting and auditing Standards for the reliability of financial statements.

PSO2 Interpret the legal and environmental aspects of business and Analyze quantitative data in order to take business decisions

PSO3. Empowering the student to understand the accounting practices and Procedures followed by different business entities.

PSO4. Promising the Practical skills for a bright career as accounting officers, computer professionals, audit assistants, businessmen, entrepreneurs, managers with required knowledge in computers.

PSO5. Knowledge of major theories and models in key areas which motivate them to pursue higher studies / face competitive exams like SSC,P.C,BANK,R.R.B/ professional courses like CA,CS, ICWA and other courses.

Programme outcomes (Pos)

PO1. Critical Thinking: Knowledgeable in the core disciplines of Commerce, Economics and Business through a number of specializations and practical exposure enables them to face the challenges in the field of Commerce

PO2. Effective Communication: Demonstrate proficiency in communicating competently in groups and organizations in English and in one Indian language,

PO3. Effective Citizenship: Ability to act with an informed awareness of issues and participate in civic life through volunteering.

PO4. Value- based development: Recognize values such as justice, trust, equity, fairness, kindness and, understand the moral Dimensions of your decisions, and accept responsibility for them.

PO5. Environment and Sustainability: Understand the issues of environmental contexts and Sustainable development.

PO6. Self-directed and Life-long Learning: promoting continuous development and improvement of the knowledge and skills needed for employment and personal fulfilment

SEMESTER – I

Course Code	Title of the Course	Instruction Hours per week	Credits	Evaluation		
				CIA MARKS	SEE	
					MARKS	DURATION
COM T11B	FUNDAMENTALS OF ACCOUNTING	5	4	25	75	3 Hrs.
COM T12A	Business Organization and Management	5	4	25	75	3 Hrs.
COM T13	Business Environment	5	4	25	75	3 Hrs.
	ENTREPRENEURSHIP DEVELOPMENT	2	2	10	40	2 Hrs.

SEMESTER-III

Course Code	Title of the Course	Instruction Hours per week	Credits	Evaluation		
				CIA MARKS	SEE	
					MARKS	DURATION
	ONLINE BUSSINESS	2	2		50	2 Hrs.
CAA301 G/C	ADVANCED ACCOUNTING	5	4	30	70	3 Hrs.
CBS303 G/C	BUSSINESS STATISTICS	5	4	30	70	3 Hrs.
CM304 G	MARKETING	5	4	30	70	3 Hrs.

SEMESTER – V

Course Code	Title of the Course	Instructors Hours per week	Credits	Evaluation		
				CIA MARKS	SEE	
					MARKS	DURATION
CBL501(U)	BUSSINESS LEADERSHIP	2	2	50	2 Hrs.	
CCOA502 G/C C	COST ACCOUNTING	5	4	30	70	3 Hrs.
CTAX 503 CC	TAXATION	5	4	30	70	3 Hrs.
CGST 503 G/C	GOOD AND SERVICE TAX FUNDAMNETALS	5	4	30	70	3 Hrs.
CCG504 G/C C	COMMERCIAL GEOGRAPHY	5	4	30	70	3Hrs
CCB505 CE G/C	CENTRAL BANKING	5	4	30	70	3Hrs
CRC506 CE G/C	RURAL AND FARM CREDIT	5	4	30	70	3Hrs



A. G & S.G. SIDDHARTHA DEGREE COLLEGE OF ARTS & SCIENCE

Vuyyuru-521165.

NAAC reaccredited at 'A' level

Autonomous -ISO 9001 – 2015 Certified

TITLE OF THE PAPER: FUNDAMENTALS OF ACCOUNTING

Semester: I

Course Code	COMT11B	Course Delivery Method	Class Room / Blended Mode - Both
Credits	4	CIA Marks	25
No. of Lecture Hours / Week	5	Semester End Exam Marks	75
Total Number of Lecture Hours	75	Total Marks	100
Year of Introduction:	Year of Offering: 2021 - 22	Year of Revision: ----	Percentage of Revision: 0%
CLASS:	1.B.COM., (gen/computer/e-commerce)		

Learning Outcomes:

- 1) The main objective of fundamental accounting is to prepare final accounts, otherwise known as the financial statements
- 2) To provide information that is useful for making business and economic decisions
3. The students of this course will be active learners and develop awareness of emerging trends in fundamentals of accounting,
4. The course will provide decision making skills to the students in the financial analysis context,
5. This course will enable the students to combine theoretical knowledge and practice of fundamentals of accounting.

COURSE OUTCOMES:

At the end of the course, the student will able to

CO 1: Identify transactions and events that need to be recorded in the books of accounts.

CO 2: Equip with the knowledge of accounting process and preparation of final accounts of sole trader.

CO 3: Develop the skill of recording financial transactions and preparation of reports in accordance with GAAP.

CO 4: Analyze the difference between cash book and pass book in terms of balance and make reconciliation.

CO 5 :Critically examine the balance sheets of a sole trader for different accounting periods.

Syllabus
FUNDAMENTALS OF ACCOUNTING

Course Details

Unit	Learning Units	Lecture Hours
I	<p>Introduction</p> <p>Need for Accounting – Definition – Objectives, – Accounting Concepts and Conventions – GAAP - Accounting Cycle - Classification of Accounts and its Rules – BookKeeping and Accounting - Double Entry Book-Keeping - Journalizing - Posting to Ledgers, Balancing of Ledger Accounts (including Problems).</p>	15
II	<p>Subsidiary Books:</p> <p>Types of Subsidiary Books - Cash Book, Three-column Cash Book- Petty Cash Book (including Problems).</p>	15
III	<p>Trial Balance and Rectification of Errors:</p> <p>Preparation of Trial balance - Errors – Meaning – Types of Errors – Rectification of Errors – Suspense Account (including Problems)</p>	15
IV	<p>Bank Reconciliation Statement:</p> <p>Need for Bank Reconciliation - Reasons for Difference between Cash Book and Pass Book Balances- Preparation of Bank Reconciliation Statement - Problems on both Favourable and Unfavourable Balance (including Problems).</p>	15
V	<p>Final Accounts:</p> <p>Preparation of Final Accounts: Trading account – Profit and Loss account – Balance Sheet – Final Accounts with Adjustments (including Problems).</p>	20

Test Book Prefer:

1. Financial Accounting By: S.P.Jain & K.L. Narang. Kalyani Publishers – New Delhi.

Reference text books:

2. Financial Accounting – Himalaya Publishers
3. Financial Accounting – Pragathi prakesh Publishers

Suggested Co-Curricular Activities:

1. Quiz Programs
2. Problem Solving Exercises
3. Seminar
4. Group Discussions on problems relating to topics covered by syllabus
5. Collection of proforma of bills and promissory notes
6. Examinations (Scheduled and surprise test)
7. Bridge Course for Non-commerce Students



A.G & S.G.SIDDHARTHA DEGREE COLLEGE OF ARTS & SCIENCE

Vuyyuru-521165.

NAAC reaccredited at 'A' level
Autonomous -ISO 9001 – 2015 Certified

TITLE OF THE PAPER: FUNDAMENTALS OF ACCOUNTING

Semester: I

Max. Marks : 75

SECTION - A

Answer any SIX of the following.

5 x 5 = 25

1. State any 5 advantages of Accounting. (CO1, L1)
2. Explain various types of Accounts and its rules. (CO1, L2)
3. Uses of Subsidiary Books. (CO2, L1)
4. Define 'Contra Entry'. What are the circumstances for passing contra entry? (CO2, L1)
5. Explain the methods for preparing Trial Balance? (CO3, L2)
6. Explain the 'Suspense account'. (CO3, L1)
7. Examine the need for Bank Reconciliation Statement. (CO4, L2)
8. Treatment of Outstanding and prepaid Expenses in final account . (CO5, L1)

SECTION – B

Answer the following

5 x10 = 50

Unit - I

9. A) Distinguish between Book Keeping and Accounting. (CO1, L2)
(OR)

B) Journalise the following transactions of Mr.Ramprasad. (CO1,L3)

- 2006 April 1 Ram prasad started business with cash Rs.50,000, furniture Rs.15,000 and stock Rs 10,000
2 Opened current account with Andhra Bank Rs.20,000
3 Received from Ragavan, a treasury order for Rs.1,000 and paid into bank.
5 Sold goods to Rama Rao for Rs 3,000
6 Drew from Bank for office use Rs.2,000
9 Sold goods for cash Rs.1,200-and out of that paid Rs.800 into Bank
10 Typewriter purchased by cheque Rs.5,000
12 Purchased goods from Sudhakar for Rs.6,000 and paid cash Rs. 2,000
14 Returned goods to Sudhakar Rs.200
16 Purchased pen,pencil,paper and ink for Rs.500 and paid by cheque
19 Sold goods to Krishna Rs.1,500 and received cash Rs.500 from him
22 Rama Rao became insolvent and 50% of the amount due is received.

Unit - II

10. A) Explain the different types of Subsidiary Books. (CO2, L2)

(OR)

B) Enter the following transactions in a Triple Column Cash Book. (CO2,L3)

2006

- Jan. 1 Cash in hand Rs. 5,374, Balance at bank Rs. 15,490
3 Cash Sales Rs. 6,400
5 Paid into bank Rs. 7,000
6 Received a cheque for Rs. 700 from Satyam
8 Paid into bank Satyam's cheque
10 Paid to Anurag by cheque Rs. 980 and discount allowed by him Rs. 20.
12 Cash purchased Rs. 2,500
14 Withdrew from bank for office use Rs. 5,000
15 Received cheque for Rs. 950 from Lakshman allowed him discount Rs. 50
18 Cash Sales Rs. 7,500
19 Paid into bank Lakshman's cheque and Cash Rs. 4,000.
21 Cash paid for Stationery Rs. 120.
23 Paid Commission to Rakesh Rs. 500
25 Received cheque for Rs. 1,000 from Mohan and Paid the same into Bank.
27 Lakshman's cheque dishonoured.
29 Drew a cheque for Rs. 800 for personal use.
31 Paid Salaries by cheque Rs. 1,500 and by cash Rs. 500.
31 Bank charges Rs. 20 and Insurance Premium Rs. 520 as shown in Pass Book.

Unit – III

11. A) Define an Error? State the different types of Errors? (CO3, L2)

(OR)

b) A book keeper prepared a Trail Balance on 31st December, 2006 which showed a difference of Rs. 140 (excess credit). The difference was placed to a suspense account. The following errors were subsequently located.

- A sale of goods to Raja for Rs. 600 had been posted to the wrong side of his account.
- A purchase of goods for Rs. 1,640 from Uma has been posted to the personal account as Rs. 640.
- A credit sale of old furniture for Rs. 150 had been passed in sales day book.
- The discount received account had been cast short Rs. 60.
- Payment of rent Rs. 340 was debited to the personal account of the landlord.

Pass Journal entries to rectify the errors and prepare the suspense account. (CO 3 L4)

Unit - IV

12. A) Explain the causes for the distinction between Cash book and Pass book balance? (CO4, L2)

(OR)

B) On 31st March 2006 the bank balance of Dinesh Agnihotri appeared at Rs. 7,654 as per the bank columns of the cash book. On reconciling with the pass book, the following facts were ascertained:

- That out of the cheques for Rs. 1,800 issued by him on 26th March, cheques worth Rs. 400 were presented to the bankers before 31st March and those

worth Rs.500 were presented on 11th April. The other cheques were not so far cashed.

2. That a Bill Receivable for Rs. 1,000 was realised by the bankers on 29th March, but no corresponding entry was passed in the cash book.
3. That out of the up country cheques for Rs.2,800 paid in on 28th March, one cheque for Rs. 900 was not yet credited by the bankers.
4. That debit in respect of the bank charges amounting to Rs. 92.50 and credits in respect of interest on investment for Rs. 150 and dividends realised Rs. 800 were not passed through the cash book.
5. That a wrong debit of Rs. 350 relating to some other account appeared in pass book.

You are required to ascertain the bank balance shown by the bank pass book on 31st March 2006. (CO4,L3)

Unit - V

13.. A. Explain the procedure for preparation of Final accounts for a sole trader.(CO5, L2)

(OR)

B. From the following Trial Balance of Smt. Girija Stores, prepare final accounts for the year ending 31-12-2015. (CO 5,L4)

Trial Balance			
Debit Balance	Amount	Credit Balance	Amount
Purchases	70,000	Sales	1,00,000
Sales Returns	1,000	Capital	80,000
Carriage	500	Purchase returns	2,000
Salaries	1,500	Creditors	25,000
Rent	1,000	Commission	2,000
Insurance	500	Provision for bad debts	2,100
Debtors	20,000	Bills payable	5,000
Plant & Machinery	50,000		
Furniture	9,000		
Cash at Bank	20,000		
Opening Stock	25,000		
Bills receivable	16,000		
Wages	1,100		
Advertisement	500		
	2,16,100		2,16,100

Adjustments:

1. Closing stock Rs 30,000
2. Outstanding salaries Rs.200
3. Depreciate Machinery by 10%, Furniture by 5%.
4. Provide 5% reserve for bad debts on debtors.
5. Prepaid wages Rs.100.



A. G & S.G. SIDDHARTHA DEGREE COLLEGE OF ARTS & SCIENCE

Vuyyuru-521165.

NAAC recredited at 'A' level

Autonomous -ISO 9001 – 2015 Certified

TITLE OF THE PAPER: Business Organization and Management

Semester: I

Course Code	COMT12A	Course Delivery Method	Class Room / Blended Mode - Both
Credits	4	CIA Marks	25
No. of Lecture Hours / Week	5	Semester End Exam Marks	75
Total Number of Lecture Hours	75	Total Marks	100
Year of Introduction:	Year of Offering: 2021 - 22	Year of Revision: ----	Percentage of Revision: 0%
CLASS:	1.B.COM., (gen/computer/e-commerce)		

Course Objectives:

CO1-Recall the basic knowledge on conceptual areas such as commerce trade and industry of different types of business organizations. (PO4, PO5)

CO2-Have a demonstrated understanding on nature purpose and importance of different types of organizations. (PO4, PO5)

CO3-Articulate the fundamentals of joint-stock company as per companies Act 2013. (PO2, PO4, PO5)

CO4-Appraise the documentation and incorporation stages of a company. (PO2, PO4, PO5)

CO5-Discuss and implement the managerial traits and talents essential for managing business. (PO1, PO4, PO5)

Learning Outcomes:

At the end of the course, the student will be able to

- Understand different forms of business organizations.
- Comprehend the nature of Joint Stock Company and formalities to promote a Company.
- Describe the Social Responsibility of Business towards the society.
- Critically examine the various organizations of the business firms and judge the best among them.
- Design and plan to register a business firm. Prepare different documents to register a company at his own.
- Articulate new models of business organizations.

Syllabus
Business Organization and Management

Course Details

Unit	Learning Units	Lecture Hours
I	Introduction Concepts of Business, Trade, Industry and Commerce: Business – Meaning, Definition, Features and Functions of Business - Trade Classification – Aids to Trade – Industry Classification and Commerce - Factors Influencing the Choice of Suitable form of Organization.	15
II	Forms of Business Organizations: Features, Merits and Demerits of Sole Proprietor Ship and Partnership Business - Features Merits and Demits of Joint Stock Companies - Public Sector Enterprises (PSEs) - Multinational Corporations (MNCs)- Differences between Private Limited Public Limited Company.	15
III	Company Incorporation: Preparation of Important Documents for Incorporation of Company - Certificate of Incorporation and Certificate of Commencement of Business - Contents of Memorandum and Articles of Association – Content of Prospectus.	15
IV	Management: Meaning Characteristics - Fayol’s 14 Principles of Management - Administration Vs. Management - Levels of Management.	15
V	Functions of Management: Different Functions of Management - Meaning – Definition – Characteristics Merits and Demits of Planning - Principles of Organization – Line and staff of Organization.	15

Text book: Business Organization and management – R.K.Sharma, Monika.

Reference Books:

Business Organization - C.D.Balaji and G. Prasad, Margham Publications, Chennai.
Business Organization -R.K.Sharma and Shashi K Gupta, Kalyani Publications.
Business Organization & Management: Sharma Shashi K. Gupta, Kalyani Publishers.

Curricular Activities:

Classroom activities: Face to face interactions in the class, conventional chalk dust method of teaching, using audio visual aids, synchronous, asynchronous and hybrid method of online, teaching by using suitable platform, spot tests, listing assignments, conduct quizzes, Google class rooms organizing group discussions, preparing question banks.

Library activities: Reading books, journals and magazines, glancing question papers of previous Years. Organization of activities like seminars, workshops and conferences

Co-Curricular Activities:

- Book Reading Quiz Programme
- Student Seminars, Debates, Field studies (Individual/Group)



**A. G & S.G. SIDDHARTHA DEGREE COLLEGE
OF ARTS & SCIENCE**

Vuyyuru-521165.

NAAC reaccruited at 'A' level
Autonomous -ISO 9001 – 2015 Certified

TITLE OF THE PAPER: Business Organization and Management

Semester: I

Section – A

Answer any FIVE of the following.

5x5=25

1. Explain the characteristics of Business. **CO1, L1**
2. Explain the types of Industries. **CO1, L1**
3. Explain the features of Sole proprietor. **CO2, L1**
4. What is partnership deed? **CO2, L1**
5. Define Joint Stock Company. What are its features? **CO3, L1**
6. Articles of Association. **CO3, L1**
7. Define Levels of Management. **CO4, L1**
8. Explain Merits of Planning. **CO5, L1**

Section – B

Answer the following.

5x10=50

Unit - I

9. A). What are the various types of Industries? **CO1,L1**
OR
B). Distinguish between Trade, Commerce and Industry. **CO1, L2**

Unit - II

10. A). Define Partnership firm. What are the characteristics of a partnership of the form of organization? **CO2, L1**
OR
B). Distinguish between private company and public company. **CO2, L2**

Unit - III

11. A) What is Memorandum of Association? What are its contents? **CO3, L1**
OR
B). Distinguish between Memorandum of Association and Articles of Association. **CO3, L2**

Unit - IV

12. A) Explain Henry Fayol's Principles of Management. **CO4, L1**
OR
B) Define Management. Distinguish between Administration and Management. **CO4, L2**

Unit - V

13. A) Define Planning. What are its characteristics? **CO5, L1**
OR
B) Define Organisation. What are the principals of Organisation? **CO5, L1**



A. G & S.G. SIDDHARTHA DEGREE COLLEGE OF ARTS & SCIENCE

Vuyyuru-521165.

NAAC reaccredited at 'A' level

Autonomous -ISO 9001 – 2015 Certified

TITLE OF THE PAPER: Business Environment

Semester: I

Course Code	COMT13	Course Delivery Method	Class Room / Blended Mode - Both
Credits	4	CIA Marks	25
No. of Lecture Hours / Week	5	Semester End Exam Marks	75
Total Number of Lecture Hours	75	Total Marks	100
Year of Introduction:	Year of Offering: 2021 - 22	Year of Revision: ----	Percentage of Revision: 0%
CLASS:	1.B.COM., (gen)		

Course Objectives:

- This course aims at acquainting the students with emerging issues in business at the National and International level in the light of policies of liberalization and Globalization.
- evaluate the economic, social political and legal environment components in business decision making.

Course Outcomes:

CO1: Understand how an entity systematically explores the external environment in which business operates.

CO2: To enlighten/familiarize the impact of economic environment and its effect on government policies for development of business.

CO3: To acquire specialized knowledge relating to economic policies in India.

CO4: critically examine the economic, social political and legal environment components in business decision making.

CO5: synthesize multiple perspective to formulate responses to opportunities and institutions in international environment.

Syllabus
Business Environment

Course Details

Unit	Learning Units	Lecture Hours
I	Overview of Business Environment: Business Environment – Meaning – Characteristics – Scope -Macro and Micro Dimensions of Business Environment -Environmental Analysis- Purpose & Techniques.	15
II	Economic Environment: Economic Environment – Nature of the Economy – Structure of Economy – Economic Policies & Planning the Economic Condition – NITI Ayog – National Development Council – Five Year Plans	15
III	Economic Policies: Economic Reforms and New Economic Policy – New Industrial Policy – Competition Law – Fiscal Policy – Objectives and Limitations – Monetary Policy and RBI	15
IV	Social, Political and Legal Environment: Concept of Social Responsibility of Business towards Stakeholders - Demonetization, GST and their Impact - Political Stability - Legal Changes	15
V	Global Environment: Globalization – Meaning – Role of WTO – WTO Functions -IBRD– Trade Blocks, BRICS, SAARC, ASEAN in Globalization	15

Text book: . Rosy Joshi and Sangam Kapoor :Business Environment

Referece Books

1. K. Aswathappa : Essentials of Business Environment, Himalaya PublishingHouse
2. Francis Cherunilam : Business Environment,HimalayaPublishingHouse
3. Dr S Sankaran: : Business Environment, MarghamPublications

Co-curricular activities

- ◆ Seminar on overview of business environment
- ◆ Debate on micro v/s macro dimensions of businessenvironment
- ◆ Seminar on Monetary policies ofRBI
- ◆ Debate on social, political and legalenvironment
- ◆ Group Discussions on Global environment and its impact onbusiness
- ◆ To learn about NITI Ayog and National DevelopmentCouncil



**A. G & S.G. SIDDHARTHA DEGREE COLLEGE
OF ARTS & SCIENCE**

Vuyyuru-521165.

NAAC reaccredited at 'A' level
Autonomous -ISO 9001 – 2015 Certified

**TITLE OF THE PAPER: Business Environment
Semester: I**

Section – A

Answer any five of the following

5 X 5M = 25M

1. What are the objectives of Business Environment? (CO1, L1)
2. Write the features of socialism (CO1, L1)
3. Write about National Development Council (CO2, L1)
4. Explain the functions of NITI Aayog (CO2, L2)
5. Describe about the structure of Indian Economy (CO3, L2)
6. List out the revenue sources to State Government (CO3, L1)
7. What is Political Environment (CO4, L1)
8. Explain BRICS (CO5, L2)

Answer the following

Section – B

5 X 10M = 50M

Unit - I

A) What is Business Environment? Explain the characteristics of Business Environment. (CO1, L1)

(or)

B) Explain micro and macro environmental factors of business environment? (CO1, L2)

Unit - II

9. A) Define economic growth? What are the determinants of economic growth? (CO2, L1)

(or)

B) Distinguish between NITI Aayog & Planning Commission. (CO2, L2)

Unit - III

11. A) Write about the monetary policy in India. (CO3, L2)

(or)

B) Explain Competition Act, 2002. (CO3, L1)

Unit - IV

12. A) Write about the social responsibility of business. (CO4, L1)

(or)

B) Explain the Impact of Demonetization on Indian Economy (CO4, L2)

Unit - V

13. A) Explain the role of WTO. (CO5, L2)

(or)

B) What is Globalization? Explain its Features. (CO5, L2)



A. G & S.G. SIDDHARTHA DEGREE COLLEGE OF ARTS & SCIENCE

Vuyyuru-521165.

NAAC recredited at 'A' level

Autonomous -ISO 9001 – 2015 Certified

TITLE OF THE PAPER: ENTREPRENEURSHIP DEVELOPMENT

Semester: I

Course Code		Course Delivery Method	Class Room / Blended Mode - Both
Credits	2	CIA Marks	10
No. of Lecture Hours / Week	2	Semester End Exam Marks	40
Total Number of Lecture Hours	30	Total Marks	100
Year of Introduction:	Year of Offering: 2021 - 22	Year of Revision: ----	Percentage of Revision: 0%
CLASS:	I B.com. (comp/e-commerce /B.Sc. MPcs)		

CO1: To familiarize students with various concepts used in understanding process involved in entrepreneurship and business formation and development.

CO2: To identify various sources to generate potential business ideas for new ventures and also enabling students to prepare a good feasibility report based on their understanding of the project appraisal techniques.

CO3: Understand the role of financial institutions in extending their support for the entrepreneur development and also acquiring thorough knowledge on various government policies and tax benefits supporting small scale industries.

Syllabus
ENTREPRENEURSHIP DEVELOPMENT

Course Details

Unit	Learning Units	Lecture Hours
I	Entrepreneurship: Entrepreneur characteristics – Classification of Entrepreneurships –Role of Entrepreneurship in economic development –Start-ups.	10
II	Idea Generation and Project Formulation: Sources of New Ideas in Entrepreneurships – Techniques for generating ideas - Preparation of Project Report –Content; Guidelines for Report preparation – Project Appraisal techniques – Economic Analysis; Financial Analysis; Market Analysis	10
III	Institutions Supporting and Taxation Benefits: Central level Institutions: NABARD; SIDBI, NSIC – state level Institutions –DICs- SFC- SSIDC- Government Policy for SSIs- tax Incentives and Concessions –Non-tax Concessions Rehabilitation and Investment Allowances.	10

Reference Books:

1. Arya Kumar, Entrepreneurship, Pearson, Delhi, 2012.
2. Poornima M.CH., Entrepreneurship Development –Small Business Enterprises, Pearson, Delhi,2009
3. Michael H. Morris, ET. al., Entrepreneurship and Innovation, Cen gage Learning, New Delhi, 2011
4. KanishkaBedi, Management and Entrepreneurship, Oxford University Press, Delhi, 2009
5. Anil Kumar, S., ET.al., Entrepreneurship Development, New Age International Publishers, New Delhi, 2011
6. Khanka, SS, Entrepreneurship Development, S. Chand, New Delhi.
7. Peter F. Drucker,Innovation and Entrepreneurship.



A. G & S.G. SIDDHARTHA DEGREE COLLEGE OF ARTS & SCIENCE

Vuyyuru-521165.

NAAC recredited at 'A' level

Autonomous -ISO 9001 – 2015 Certified

TITLE OF THE PAPER: ENTREPRENEURSHIP DEVELOPMENT

Semester: I

Section - A

I Answer any TWO of the following:

2 X 5M = 10M

1. Explain the functions of startup companies.
2. Explain the various sources of new ideas in developing a business idea
3. Explain any two project appraisal techniques
4. Write about Rehabilitation allowance and investment allowance.

Section - B

II Answer any THREE of the following:

3 X 10M = 30M

5. Explain the role of an Entrepreneur in the Economic development of a country.
6. Write about the Classification of Entrepreneurships
7. Develop guidelines for report preparation
8. Give an account of any three central level institutions.
9. Write about the Tax-Concessions offered to SSIs.



A. G & S.G. SIDDHARTHA DEGREE COLLEGE OF ARTS & SCIENCE

Vuyyuru-521165.

NAAC reaccruited at 'A' level

Autonomous -ISO 9001 – 2015 Certified

TITLE OF THE PAPER: Advanced Accounting
Semester: III

Course Code	CAA-302G/C	Course Delivery Method	Class Room / Blended Mode - Both
Credits	4	CIA Marks	30
No. of Lecture Hours / Week	5	Semester End Exam Marks	70
Total Number of Lecture Hours	75	Total Marks	100
Year of Introduction:	Year of Offering: 2021 - 22	Year of Revision: ----	Percentage of Revision: 0%
CLASS:	I1.B.COM., (gen/computer)		

Learning Outcomes:

At the end of the course, the student will able to

- ❖ Understand the concept of Non-profit organization's and its accounting process
- ❖ Comprehend the concept of single-entry system and preparation of statement of affairs
- ❖ Familiarize with the legal formalities at the time of dissolution of the firm
- ❖ Prepare financial statements for partnership firm on dissolution of the firm
- ❖ Employ critical thinking skills to understand the difference between the dissolution of the firm and dissolution of partnership

Syllabus
Advanced Accounting

Course Details

Unit	Learning Units	Lecture Hours
I	Accounting for Non-Profit Organisations: Non-Profit Entities-Meaning - Features of Non-Profit Entities –Provisions as per Sec 8 - Accounting Process- Preparation of Accounting Records - Receipts and Payments Account- Income and Expenditure Account - Preparation of Balance Sheet (including problems)	15
II	Single Entry System: Features – Differences between Single Entry and Double Entry – Disadvantages of Single Entry-Ascertainment of Profit and Preparation of Statement of Affairs (including Problems).	15
III	Hire Purchase System: Features –Difference between Hire Purchase and Instalment Purchase Systems - Accounting Treatment in the Books of Hire Purchaser and Hire Vendor - Default and Repossession (including Problems)	15
IV	Partnership Accounts-I: Meaning – Partnership Deed - Fixed and Fluctuating Capitals-Accounting Treatment of Goodwill - Admission and Retirement of a Partner (including problems)	15
V	Partnership Accounts-II: Dissolution of a Partnership Firm – Application of Garner v/s Murray Rule in India – Insolvency of one or more Partners (including problems).	15

Reference Books:

1. Corporate Accounting – Haneef & Mukherji,
2. Corporate Accounting – RL Gupta & Radha swami
3. Corporate Accounting – P.C. Tulsian



A. G & S.G. SIDDHARTHA DEGREE COLLEGE OF ARTS & SCIENCE

Vuyyuru-521165.

NAAC recredited at 'A' level

Autonomous -ISO 9001 – 2015 Certified

**TITLE OF THE PAPER: Advanced Accounting
Semester: III**

Model Question Paper

Time: 3 hours

Max. Marks: 70

SECTION - A

I. Answer any TWO of the following questions

2 x 5 =10M

1. Write the features of Non Profit Organizations
2. Write about Repossession of Goods
3. Explain different types of partners
4. Garner vs Murry Case

SECTION - B

II. Answer any FOUR of the following questions

4 x15 =60M

- 5).Discribe the Difeerrnce between Hire purchase and Installment Purchase System
- 6). write the Difference between Income and Expenditure account and Receipts and payment accounts
- 7) Write about fixed and fluctuating Capital Methods

8).The following is the Receipts and Payments Account of Indian Sports Club for the first year Ending as on 31-3-2014

Receipts	Rs.	Payments	Rs.
To Donations	5,00,000	By Pavilion constructed	4,00,0000
To Reserve fund (life and Entrance fee)	40,000	By Expenditure in connective with matches	9,000 600
To Receipts from matches	80,000	By Furniture	21,000
To Revenue receipts		By investment at cost	160000
Subscription	52,000	By Revenue Payments	
Locker Rent	500	Salaries	18,000
interest on securities	2400	Wages	6000
Sundries	3500	Insurance	3,500
		Telephone	2500
		Electricity	1100
		Sundry expenses	2100
		By Balance on hand	55200
	6,78,400		6,78,400

Additional information:

1. Donations received have to be Capitalised .
2. Outstanding bills for sundry expenses Rs.400
3. Wages unpaid for the year Rs.900
4. Salaries unpaid for the year Rs. 1700
5. Subscriptions outstanding for the year Rs. 2500

Prepare income and Expenditure account and the balance sheet for the year ended 31-3-2014

9). A motor company purchased two trucks on 1st Jan 2004. The cost price being Rs. 56,000. The purchase is on Hire purchase basis. Rs. 15,000 being paid. On signing the agreement and there after Rs. 15,000 being paid annually for 3 years. Interest was charged at 5%. Depreciation was written off at the rate of 20% per annum on the reducing installment system. Give necessary journal entries in the books of motor company.

10). A trader keeps his books by the single entry method. His position on 31st March 2018 was as follows:

Particulars	Amount
Cash at bank	9,000
Stock	60,000
Debtors	90,000
Machinery	150,000
Creditors	69,000

His position on 31st March 2019 was as follows :

Particulars	Amount
Cash at bank	12,000
Stock	75,000
Debtors	135,000
Machinery	135,000
Creditors	75,000

During the year the trader introduced Rs.30,000 as further capital in the business and withdraw Rs.900 per month. From the above you are required to ascertain the profit or loss made by the trader for the year ended 31st March 2019.

11). Kumar, Ramji are partners in a business sharing profits and losses equally. Their balance sheet on 31st December 2005 stood as under.

Liabilities	Amount	Assets	Amount
Creditors	2,000	Cash at bank	1,000
Capital Accounts:		Sundry Debtors	5,000
Kumar	40,000	Stock	10,000
Ramji	28,000	Machinery	18,000
		Furniture	5,000
		Buildings	31,000
	70,000		70,000

They decided to admit Sinha into firm on 1st Jan 2006 on the following terms.

- (a) Sinha has to pay Rs. 25,000 for 1/4 share in future profits.
- (b) Sinha has to pay Rs. 8,000 for goodwill.
- (c) Machinery be depreciated by 10% and stock be depreciated by 10%.
- (d) 5% reserve for doubtful debts be created on debtors.
- (e) Buildings to be appreciated by 20%.

Pass necessary journal entries to give effect to the above arrangement and the opening balance sheet of a Kumar, Ramji and Sinha.

12) Krishna and Kishore are equal partners in a business. They agreed to dissolve the partnership on 31st December 2006. On which date their Balance Sheet was as follows.

Liabilities	Amount	Assets	Amount
Sundry creditors	2,580	Cash at bank	1,500
Capital Accounts		Sundry debtors	2,775
Krishna 7,500		Stock	7,575
Kishore 6,000	13,500	Furniture	1,500
		Premises	3,000
	16,350		16,350

The assets realised as follows.

Premises Rs. 3,180, Furniture Rs.1,650, and Stock Rs. 6,900. The debtors realized Rs. 2,700.

The creditors were paid Rs. 2,800 in full settlement

The realisation expenses amounted to Rs. 300

Pass necessary journal entries and show the realisation account, bank account and partners capital account.



A. G & S.G. SIDDHARTHA DEGREE COLLEGE OF ARTS & SCIENCE

Vuyyuru-521165.

NAAC reaccruited at 'A' level

Autonomous -ISO 9001 – 2015 Certified

TITLE OF THE PAPER: **Advanced Accounting** **Semester: III**

Guidelines to the paper setter

Marks	UNIT-I	UNIT-II	UNIT-III	UNIT-IV	UNIT-V
	Accounting for Non Profit Organisations	Single Entry System	Hire Purchase System	Partnership Accounts-I	Partnership Accounts-II
5Marks	1	1	0	1	1
15Marks	1T+1P	1P	1T+1P	1T+1P	1P
Weight age	35	20	35	15	20



A. G & S.G. SIDDHARTHA DEGREE COLLEGE OF ARTS & SCIENCE

Vuyyuru-521165.

NAAC recredited at 'A' level
Autonomous -ISO 9001 – 2015 Certified

TITLE OF THE PAPER: Business Statistics
Semester: III

Course Code	CBS-303G/C	Course Delivery Method	Class Room / Blended Mode - Both
Credits	4	CIA Marks	30
No. of Lecture Hours / Week	5	Semester End Exam Marks	70
Total Number of Lecture Hours	75	Total Marks	100
Year of Introduction:	Year of Offering: 2021 - 22	Year of Revision: ----	Percentage of Revision: 0%
CLASS:	II.B.COM.,(gen/computer)		

Course Objective:

1.The objective of this course is to impart knowledge on the application of Statistical tools and techniques in business decision making.

2. To make the students acquire the knowledge of Design, evaluate and apply correlation analysis

Learning Outcomes:

CO1- Describe the structure and characteristics of statistical data. able to present the data with diagrams

CO2- Calculate and interpret measures of central tendency and variability in statistical data.

CO3- Calculate and interpret measures of dispersion and skewness

CO4- Design, evaluate and apply correlation analysis.

CO5- To study the past behaviour of data and measure the effect of changes over the period of time.

Syllabus Business Statistics

Course Details

Unit	Learning Units	Lecture Hours
I	Introduction to Statistics: Definition, Importance and limitation of statistics, Collection of data, Schedule and questionnaire, Frequency distribution, Tabulation	10
II	Measures of Central Tendency: Characteristics of measures of central tendency, Types of Averages, Arithmetic Mean, Geometric Mean, Harmonic Mean, Median, Mode	15
III	Measures of dispersion and Skewness: Properties of dispersion, Range, Quartile Deviation, Mean deviation, Standard deviation, Coefficient of Variation, Skewness Definition, Karl Pearson's and Bowley's Measures Of skewness	15
IV	Measures of Relation: Meaning and use of correlation, Types of correlation, Karl Pearson's correlation coefficient, Probable Error, Spearman's Rank correlation, Regression analysis comparison between correlation and Regression, Regression Equations	15
V	Analysis of Time Series & Index Numbers Meaning and utility of time series, Components of Time series, Measurement of trend and Seasonal Variations, Techniques of Time series analysis, Methods of averages(Semi , Moving averages), Least square method, Index Numbers, Methods of Construction of Index numbers, Price index numbers, Limitations of index numbers	20

Suggested Readings:

1. Business Statistics Reddy, C.R Deep Publications.
2. Statistics-Problems and Solutions Kapoor V.K.



A. G & S.G. SIDDHARTHA DEGREE COLLEGE OF ARTS & SCIENCE

Vuyyuru-521165.

NAAC reaccredited at 'A' level

Autonomous -ISO 9001 – 2015 Certified

TITLE OF THE PAPER: Business Statistics
Semester: III

Model Question Paper

Time: 3 hours

Max. Marks: 70

SECTION - A

I. Answer any TWO of the following questions

2× 5 = 10 M

1. What are the Limitations of Statistics.
2. What are the different types of average?
3. Explain the Skewness?
4. Explain the Different types of Correlation ?

SECTION - B

II. Answer any FOUR of the following

4×15 =60 M

5. What is Questionnaire? Discuss the precautions to be taken while preparing a Questionnaire.
6. Calculate Mode.

C.I	10-20	20-30	30-40	40-50	50-60	60-70
F	4	7	16	20	15	8

7. Calculate Mean deviation.

C.I	10-15	15-20	20-25	25-30	30-35	35-40	40-45	45-50
F	8	10	12	15	10	7	8	5

8. Calculate Bowley's Skewness

X	6	12	18	24	20	16	6
F	4	7	9	18	15	10	5

9. Calculate Arithmetic Mean.

C.I	10-20	20-30	30-40	40-50	50-60	60-70	70-80
F	5	9	18	27	12	15	17

10. Calculate Karl Pearson's coefficient of correlation from the following.

A	44	80	76	48	52	72	68	56	60
B	48	75	54	60	63	69	72	51	57

11. What is Time Series Explain the Components of Time Series?

12. From the following data given Find fishers Index Number.

Commodity	Base year		Current year	
	Price	Quantity	Price	Quantity
A	6	50	10	56
B	2	100	2	120
C	4	60	6	60
D	10	30	12	24
E	8	40	12	36



A. G & S.G. SIDDHARTHA DEGREE COLLEGE OF ARTS & SCIENCE

Vuyyuru-521165.

NAAC recredited at 'A' level

Autonomous -ISO 9001 – 2015 Certified

TITLE OF THE PAPER: Business Statistics

Semester: III

Guidelines to the paper setter

Marks	UNIT-I	UNIT-II	UNIT-III	UNIT-IV	UNIT-V
	Introduction to Statistics	Measures of Central Tendency	Measures of dispersion and Skewness	Measures of Relation	Analysis of Time Series & Index Numbers
5Marks	1	1	1	1	0
15Marks	1T	2P	2P	1P	1T+1P
Weight age	20	35	35	20	30



A. G & S.G. SIDDHARTHA DEGREE COLLEGE OF ARTS & SCIENCE

Vuyyuru-521165.

NAAC reaccredited at 'A' level

Autonomous -ISO 9001 – 2015 Certified

TITLE OF THE PAPER: Marketing
Semester: III

Course Code	CM 304 G	Course Delivery Method	Class Room / Blended Mode - Both
Credits	4	CIA Marks	30
No. of Lecture Hours / Week	5	Semester End Exam Marks	70
Total Number of Lecture Hours	75	Total Marks	100
Year of Introduction:	Year of Offering: 2021 - 22	Year of Revision: ----	Percentage of Revision: 0%
CLASS:	I1.B.COM.,(gen)		

Course Objective:

- 1.To acquire knowledge on marketing concepts, 4P's, to build applicable skills through variety internship opportunities
2. Student will gain understanding of consumer buyer behaviour, pricing strategies and ethical concept of marketing

Learning Outcomes:

- CO1: To introduce the concepts of marketing and understand the factors influence the market environment.
- CO2: Analyze the consumer market models and enlightens consumer buyer behaviour models.
- CO3: Understand the concept of product and identify the need of product mix and product line decisions.
- CO4: Develop an idea about pricing strategies and pricing decisions.
- CO5: Enhance the students about decisions regarding promotion and distribution channels.

SYLLABUS

Marketing

Course Details

Unit	Learning Units	Lecture Hours
I	Introduction: Concepts of Marketing: Need, Wants and Demand - Marketing Concepts – Marketing Mix - 4 P's of Marketing – Marketing Environment.	15
II	Consumer Behaviour and Market Segmentation: Buying Decision Process – Stages – Buying Behaviour – Market Segmentation –Bases of Segmentation - Selecting Segments – Advantages of Segmentation	15
III	Product Management: Product Classification – Levels of Product - Product Life Cycle - New Products, Product Mix and Product Line Decisions - Design, Branding, Packaging and Labelling.	15
IV	Pricing Decision: Factors Influencing Price – Determination of Price - Pricing Strategies: Skimming and Penetration Pricing.	15
V	Promotion and Distribution: Promotion Mix - Advertising - Sales promotion - Publicity – Public Relations - Personal Selling and Direct Marketing - Distribution Channels – Online Marketing	15

References:

1. Philip Kotler, Marketing Management, Prentice Hall of India.
2. Philip Kotler & Gary Armstrong, Principles of Marketing, Pearson Prentice
3. Stanton J. William & Charles Futrel, Fundamentals of Marketing, McGraw Hill Company



A. G & S.G. SIDDHARTHA DEGREE COLLEGE OF ARTS & SCIENCE

Vuyyuru-521165.

NAAC reaccredited at 'A' level

Autonomous -ISO 9001 – 2015 Certified

TITLE OF THE PAPER: Marketing
Semester: III

Model paper

Time: 3 hrs

Max. Marks: 70

SECTION- A

I. Answer any TWO of the following questions

2x 5= 10M

1. Selling Concept
2. What is Consumer behavior
3. What is New Product
4. Online Marketing

SECTION- B

II. Answer any FOUR of the following questions

4 x 15 = 60M

5. Describe 4P's of Marketing
6. What are the Different Concepts of Marketing
7. What is Market Segmentation?
8. Describe Product Life Cycle.
9. What are the Factor Influencing Price Determination
10. What are the differences Between Personal selling and Direct Marketing?
11. Advantages and disadvantages Packaging and labelling
12. Types of Distribution channels



A. G & S.G. SIDDHARTHA DEGREE COLLEGE OF ARTS & SCIENCE

Vuyyuru-521165.

NAAC reaccredited at 'A' level

Autonomous -ISO 9001 – 2015 Certified

TITLE OF THE PAPER: **Marketing**

Semester: III

Guidelines to the paper setter

Marks	UNIT-I	UNIT-II	UNIT-III	UNIT-IV	UNIT-V
	Introduction	Consumer Markets and buyer Behaviour	Product Management	Pricing decision	Promotion and Distribution
5Marks	1	1	1	--	1
15Marks	2	1	2	1	2
Weightage	35	20	35	15	35



A. G & S.G. SIDDHARTHA DEGREE COLLEGE OF ARTS & SCIENCE

Vuyyuru-521165.

NAAC reaccredited at 'A' level
Autonomous -ISO 9001 – 2015 Certified

TITLE OF THE PAPER: **Business Leadership**
Semester: V

Course Code	CBL-501(U)	Course Delivery Method	Class Room / Blended Mode - Both
Credits	2	CIA Marks	-
No. of Lecture Hours / Week	2	Semester End Exam Marks	50
Total Number of Lecture Hours	30	Total Marks	50
Year of Introduction:	Year of Offering: 2021 - 22	Year of Revision: ----	Percentage of Revision: 0%
CLASS:	III.B.COM.,(gen/computer)		

COURSE OBJECTIVES:

To make the students acquire the knowledge in leadership

To impart leadership skills among the students

COURSE OUTCOMES:

CO1: Students able to learn leadership skills

CO2: students impart knowledge about leadership in organisations.

CO3: students can build an idea about familiar business persons

SYLLABUS

Business Leadership

Course Details

Unit	Learning Units	Lecture Hours
I	Unit-I: Introductory: Leadership - Traits, Skills and Styles- Leadership Development - Qualities of a Good Leader.	10
II	Unit-II: Decision-Making and Leadership: Leadership for Sustainability - Power, Influence, Impact - Leadership Practices - Organizations and Groups: Organizational Culture and Leadership - Leadership in Business Organizations	10
III	Unit-III: Special Topics: Profiles of a few Inspirational Leaders in Business – Jemshedji Tata - Aditya Birla - Swaraj Paul - L N Mittal - N R Narayana Murthy - Azim Premji, etc.	10

References:

1. Northouse, Peter G., Leadership: Theory and Practice, Sage Publications.
2. Daloz Parks, S., Leadership can be taught: A Bold Approach for a Complex World, Boston: Harvard Business School Press.
3. Drucker Foundation (Ed.), Leading Beyond the Walls, San Francisco: Jossey Bass.
4. Al Gini and Ronald M. Green, Virtues of Outstanding Leaders: Leadership and Character, John Wiley & Sons Inc.
5. S Balasubramanian, The Art of Business Leadership – Indian Experiences, Sage Publications



**A. G & S.G. SIDDHARTHA DEGREE COLLEGE
OF ARTS & SCIENCE**

Vuyyuru-521165.

**NAAC recredited at 'A' level
Autonomous -ISO 9001 – 2015 Certified**

**TITLE OF THE PAPER: Business Leadership
Semester: V**

Model paper

Time: 2 hrs

Max. Marks: 50

SECTION- A

I. Answer any FOUR of the following questions

4 x 5= 20M

1. Leadership
2. Trait
3. Power
4. Influence
5. Aditya Birla
6. Azim Premji

SECTION- B

II. Answer any THREE of the following questions

3 x 10 = 30M

7. Explain the qualities of Good leader
8. Explain Different types of leader ship Practices
9. Explain the leadership in Business Organizations
10. Explain the Profiles of Jemshedji Tata
11. Explain the different Styles of Leadership
12. Explain the Profiles of Narayana Murthy



A. G & S.G. SIDDHARTHA DEGREE COLLEGE OF ARTS & SCIENCE

Vuyyuru-521165.

NAAC recredited at 'A' level
Autonomous -ISO 9001 – 2015 Certified

TITLE OF THE PAPER: Business Leadership
Semester: V

Guidelines to the paper setter

	UNIT-I	UNIT-II	UNIT-III
	Introduction	Decision making and Leadership	Special Topics
5 Marks questions	2	2	2
10 Marks questions	2	2	2
Weight age	30	30	30



A. G & S.G. SIDDHARTHA DEGREE COLLEGE OF ARTS & SCIENCE

Vuyyuru-521165.

NAAC reaccredited at 'A' level

Autonomous -ISO 9001 – 2015 Certified

TITLE OF THE PAPER: Cost Accounting
Semester: V

Course Code	CCOA-502 G/C C	Course Delivery Method	Class Room / Blended Mode - Both
Credits	4	CIA Marks	30
No. of Lecture Hours / Week	5	Semester End Exam Marks	70
Total Number of Lecture Hours	75	Total Marks	100
Year of Introduction:	Year of Offering: 2021 - 22	Year of Revision: ----	Percentage of Revision: 0%
CLASS:	III.B.COM.,(gen/computer)		

Course Objective:

1. To understand the basic concepts and process used determine product costs,
2. To be able to interpret cost accounting statements, and evaluate information for cost ascertainment planning, control and decision making

COURSE OUTCOMES:

- CO1: Impart knowledge on the fundamental concept of cost accounting.
- CO2: Comprehend the knowledge in effective control of raw materials and work in progress.
- CO3: Build an idea about incentive plans based on production and cost savings.
- CO4- C04: Familiarize the students about the production progress with the help of departmental manager.
- CO5- Students will understand the profit-making decisions in complex situations of any business Organisation.

SYLLABUS

Cost Accounting

Course Details

Unit	Learning Units	Lecture Hours
I	Introduction: Distinguish between Financial Accounting, Cost Accounting and management accounting - Cost Concepts and Classification – Cost Centre and Cost Unit – Preparation of Cost Sheet.	15
II	Elements of Cost: Materials: Material control – Selective control, ABC technique – Methods of pricing issues – FIFO, LIFO, Weighted average, Base stock methods, choice of method(including problems).	15
III	Labour and Overheads: Labour: Control of labour costs – time keeping and time booking – Idle time –Methods of remuneration – labour incentives schemes - Overheads: Allocation and apportionment of overheads – Machine hour rate.	15
IV	Methods of Costing: Job costing – Process costing - treatment of normal and abnormal process losses – preparation of process cost accounts – treatment of waste and scrap, joint products and by products (including problems).	15
V	Costing Techniques: Marginal Costing – Standard costing – Variance Analysis (including problems).	15

References:

1. S.P. Jain and K.L. Narang – Advanced Cost Accounting, Kalyani Publishers, Ludhiana.
2. M.N. Aurora – A test book of Cost Accounting, Vikas Publishing House Pvt. Ltd.
3. S.P. Iyengar – Cost Accounting, Sultan Chand & Sons.
4. Nigam & Sharma – Cost Accounting Principles and Applications, S.Chand & Sons.
5. S.N .Maheswari – Principles of Management Accounting.
6. I.M .Pandey – Management Accounting, Vikas Publishing House Pvt. Ltd.



**A. G & S.G. SIDDHARTHA DEGREE COLLEGE
OF ARTS & SCIENCE**

Vuyyuru-521165.

NAAC recredited at 'A' level

Autonomous -ISO 9001 – 2015 Certified

**TITLE OF THE PAPER: Cost Accounting
Semester: V**

Model paper

TIME -3hrs

SECTION-A

Max. Marks: 70

I. Answer any TWO of the following:

2x5=10M

1. Define Cost Accounting? Explain its Advantages.
2. Explain about FIFO Method.
3. What are the essential features of a good wage system?
4. Explain about BEP Analysis.

SECTION-B

II. Answer any FOUR of the following:

4x15=60M

5. Distinguish between cost accounting and financial accounting

6. From the following particulars you are required to prepare a cost sheet for the year ending 31.12.2009. Rs.

Stock of finished goods 31-12-2008	72,800.
Stock of raw materials on 31-12-2008	33,280.
Purchase of raw materials	7,59,200.
Wages	5,16,880.
Sales	15,39,200.
Stock of finished goods on 31-12-2009	78,000.
Stock of Raw materials on 31-12-2009	35,360
Works overhead charges	1,29,220
Office overheads	70,161

The company is intending to send a quotation for a large plant. The estimated material cost is Rs. 52,000 and wages Rs. 31,200. The quotation is to make a profit of 20% on selling price. Show the amount of quotation price.

7. X Ltd has purchased and issued the material in the following order

Jan	1	Purchased	300 units @Rs.3/-per units
	4	purchased	600 <u>units@Rs.4/-per</u> units
	6	Issue	500 units
	10	Purchased	700 <u>units@Rs.4/</u> per units
	15	Issue	800 units
	20.	purchased	300 units @Rs.5/per units
	23.	issue	100 units

Ascertain the quantity of closing stock as on 31st January and state what will be its value (in each case) if issues are made under the First in first out method:

8. From the following information relating to a worker. Calculate which of the following methods of wage payment is beneficial to the worker:

- (a) Time rate
- (b) Piece rate
- (c) Halsey plan.
- (I) Standard Time in a week 45 hrs
- (ii) Standard weekly production 450 units.
- (III) Actual time taken by the worker 40hrs.
- (Iv) Piece rate Rs.2 per units
- (v) Hourly rate Rs.25.

9. Product x is obtained after it is processed through three distinct process. The following cost information is available for the operations:

particulars	Total	I	II	III
Material	5,625	2,600	2,000	1,025
Direct wages	7,330	2,250	3,680	1,400
Production over heads	7,330	–	–	–

500 units at Rs.4per unit were introduced in process .production over head to be distributed at 100% on Direct wages

The actual output and normal loss of the respective processes are:

	Output unit	Normal loss on input	Value of scrap per unit
Process-I	450	10%	Rs.2
Process-II	340	20%	Rs.4
Process-III	270	25%	Rs.5

There is no stock or work-in-progress in any process.

Prepare process accounts.

10. From the following information pertaining to the two years, calculate.

- P/V ratio
- Amount of sales to earn profit of Rs40,000
- profit on sales Rs.1,20,000.

Years	Sales	Profit
1996	1,40,000	15,000
1997	1,60,000	20,000

11. You are required to calculate from the following data:

- Material price variance
- Material cost variance
- Material usage variance

Standard material cost to produce one tone of chemical “P” is

- 500 kg of material X @Rs.15 per kg.
- 750 kg of material Y @Rs.10 per kg.
- 1000 kg of material Z @Rs.12 per kg.

During the period 100 tons of Chemical P wear produced from the usage of

- 6000 kg of material X@Rs.14 per kg.
- 8000 kg material Y @Rs .12 per kg.
- 10,500 kg materialZ@Rs.15 per kg.

12. The Costing records of Gopi Engineering Company for job 777 reveals Materials Rs 6,015

Wages: Dept .X : 100 Hours @ Rs 4.50 per hour

 Dept .Y : 65 Hours @ Rs 3.00 per hour

 Dept .Z : 35 Hours @ Rs 7.50 per hour

Over head expenses for these three departments were estimated as follows.

Variable overheads :

 Dept .X : Rs 10,000 for 2,500 labour hours

 Dept .Y Rs 6,000 for 2,000 labour hours

 Dept .Z : Rs 4,000 for 500 labour hours

Fixed overheads: estimated at Rs 40,000 for 10,000 Normal Working Hours .you are required to calculate the cost of job No 777.



A. G & S.G. SIDDHARTHA DEGREE COLLEGE OF ARTS & SCIENCE

Vuyyuru-521165.

NAAC reaccruited at 'A' level
Autonomous -ISO 9001 – 2015 Certified

TITLE OF THE PAPER: Cost Accounting
Semester: V

Guidelines to the paper setter

	UNIT-I	UNIT-II	UNIT-III	UNIT-IV	UNIT-V
	Introduction	Elements of Cost	Labour and Over heads	Methods of Costing	Costing Techniques
5 Marks questions	1	1	1	0	1
15 Marks questions	2(1T+1P)	1	1	2	2
Weight age	35	20	20	30	35



A. G & S.G. SIDDHARTHA DEGREE COLLEGE OF ARTS & SCIENCE

Vuyyuru-521165.

NAAC recredited at 'A' level
Autonomous -ISO 9001 – 2015 Certified

TITLE OF THE PAPER: TAXATION
Semester: V

Course Code	CTAX-503C C	Course Delivery Method	Class Room / Blended Mode - Both
Credits	4	CIA Marks	30
No. of Lecture Hours / Week	5	Semester End Exam Marks	70
Total Number of Lecture Hours	75	Total Marks	100
Year of Introduction:	Year of Offering: 2021 - 22	Year of Revision: ----	Percentage of Revision: 0%
CLASS:	III B. Com(comp)		

Course OBJECTIVES:

1. Demonstrate knowledge of the concepts, principles, and rules of taxation of individuals and small businesses
2. Recognize tax planning opportunities and recommend appropriate tax-saving strategies for decision making
3. Address tax situations for a variety of taxpayers, such as wage earners, salespersons, owners of small business, professionals, investors, home and rental property owners, farmers, etc

Learning Outcomes:

CO1: Impact knowledge on the provisions of income tax law and practice and acquire knowledge about Exempted incomes and residential status of an individual

CO2: Acquire Knowledge about Service tax -VAT -Central Sales Tax and GST

CO3: Enlist the ability of provisions of income from salary and its taxability. The student can build an idea about income from house property and its taxability. The student can acquire knowledge in calculation of Capital gains and Income from other sources

CO4: Impact knowledge on Taxation system in India and Modes of Tax Recovery and acquire knowledge on Filing of Returns

CO5: Recognize tax planning opportunities and recommend appropriate tax-saving strategies for decision making

SYLLABUS

TAXATION

Course Details

Unit	Learning Units	Lecture Hours
I	Introduction: Objectives - Principles of Taxation - Brief History - Basic Concepts; Capital and Revenue; Basis of Charge - Exempted Incomes - Residential Status – Incidence of Taxation.	10
II	Direct and Indirect Taxes – Service Tax – VAT – Central Sales Tax – Latest Developments.	10
III	Computation of income under different heads: Income from Salary; Income from House Property; Deductions u/s 80C to 80U - Income from Capital Gains; Income from Other Sources (simple problems).	30
IV	Taxation System in India: Objectives; Tax Holiday; Modes of Tax Recovery (Section 190 and 202); Payments and Refunds; Filing of Returns.	15
V	Tax Planning: Tax Avoidance and Tax Evasion; Penalties and Prosecutions; Income Tax Authorities.	10

References:

1. Vinod K. Singhania Direct Taxes - Law and Practice, Taxman Publication.
2. B.B. Lal: Direct Taxes, Konark Publisher (P) Ltd.
3. Bhagwati Prasad: Direct Taxes – Law and Practice, Wishwa Prakashan.
4. Dr. Mehrotra and Goyal: Direct Taxes – Law and Practice, Sahitya Bhavan Publication.



A. G & S.G. SIDDHARTHA DEGREE COLLEGE OF ARTS & SCIENCE

Vuyyuru-521165.

NAAC reaccredited at 'A' level
Autonomous -ISO 9001 – 2015 Certified

TITLE OF THE PAPER: TAXATION
Semester: V

Model Question Paper

Time: 3 Hrs

Max. Marks: 70

SECTION – A

I. Answer any TWO of the following

2X 5 = 10M

1. Explain the principle of Taxation
2. What is VAT
3. U/S 80c
4. Tax Evasion

SECTION – B

II. Answer any Four of the following

4 x15 =60M

5. Give 10 Examples of Incomes Exempted u/s 10.
6. What is Service tax ? Explain different taxable service
7. From the following particulars of sriram, a manger of a firm, compute his taxable income from salary for the A.Y 2017-18
 - a) Basic pay Rs 6000 P.M
 - b) Dearness allowance Rs 400 P.M
 - c) Own contribution to R.P.F Rs 3000 P.M
 - d)Employee's contribution to R.P.F Rs 3000 P.M
 - e) Interested credited to R.P.F 13% P.A Rs 4680
 - f) House rent allowance Rs 7200P.M rent paid in Delhi Rs5000 P.M
 - g) Medical allowance Rs100 P.M
 - h) Entertainment allowance Rs. 300 P.M

8. Compute income from House property for the assessment year 2016-17

Municipal valuation 16,000 P A. Fair rent 1,80,000 P.A ,Standard rent 1,50,000 P.A , Rent received 1,72,000 P A Municipal taxes 10% Municipal taxes are borne by the owner. Fire insurance Rs 3000, Interest on money borrowed for construction of House property paid Rs .36, 000 The House is let-out throughout the previous year.

9. Mr. Prasad submits the following particulars about sale of assets during 2016-17.

<u>Particulars</u>	<u>Jewellery</u>	<u>Plot</u>	<u>Gold</u>
Sale Price	12, 00,000	50, 80,000	10,20,000
Expenses on sale	10,000	36,000	Nil
Cost of Acquisition	90,000	4, 20,000	1,30,000
Year of Acquisition	1989-90	1986-87	2003-04
CII	172	140	463

He has purchased a house for Rs.27, 00,000 on 1-3-2020.

Calculate the amount of taxable capital gain. CII for 2021-2022 is: 317

10. Explain the Modes of Tax Recovery

11. Difference between Tax Planning and Tax Evasion

12. Mention the different Kinds of Incomes Specifically mentioned as Chargeable to tax under the head "Income from Other Sources"



A. G & S.G. SIDDHARTHA DEGREE COLLEGE OF ARTS & SCIENCE

Vuyyuru-521165.

NAAC reaccredited at 'A' level
Autonomous -ISO 9001 – 2015 Certified

TITLE OF THE PAPER: TAXATION

Semester: V

Guidelines to the paper setter

Marks	UNIT-I	UNIT-II	UNIT-III	UNIT-IV	UNIT-V
	Introduction	Direct and Indirect taxes	Computation of income under different heads	Taxation System in India	Tax Planning
5Marks	1	1	1	0	1
15Marks	1T	1T	3P+1T	1T	1T
Weight age	20	20	65	15	20



A. G & S.G. SIDDHARTHA DEGREE COLLEGE OF ARTS & SCIENCE

Vuyyuru-521165.

NAAC recredited at 'A' level
Autonomous -ISO 9001 – 2015 Certified

TITLE OF THE PAPER: GOODS & SERVICE TAX FUNDAMENTALS
Semester: V

Course Code	CGST-503G/C	Course Delivery Method	Class Room / Blended Mode - Both
Credits	4	CIA Marks	30
No. of Lecture Hours / Week	5	Semester End Exam Marks	70
Total Number of Lecture Hours	75	Total Marks	100
Year of Introduction:	Year of Offering:	Year of Revision: ----	Percentage of Revision: 0%
CLASS:	III B. Com(gen)		

Course Objectives:

1. Demonstrate knowledge of the concepts, principles, and models of goods & service tax
2. To equip the students with the knowledge of laying rules regulations and notifications in GST council
3. To provide and enable the students with the basic knowledge of Input tax credit

Learning Outcomes:

CO1: Impact knowledge on the Overview of GST and Justification for Introduction of GST and acquire knowledge about Constitutional Amendments in GST

CO2: Students get knowledge about GST Principles and Models of GST Austrian, Canadian; the student can build an idea about Comprehensive Structure of GST model in India

CO3: The student will be able to understand Taxes and Duties under GST and also Taxation of services and Tax on Petroleum products

CO4: The student can build an idea about IGST Model and also Transactions within a State under GST

CO5: Students get knowledge about Value of Supply - Input Tax Credit and Distribution of Credit, Matching of Input Tax Credit

SYLLABUS

GOODS & SERVICE TAX FUNDAMENTALS

Course Details:

Unit	Learning Units	Lecture Hours
I	Introduction: Overview of GST - Concepts – Limitations of VAT – Need for Tax Reforms - Justification for introduction of GST - Shortcomings and advantages at the Central Level and State Level on introduction of GST- Process of Introduction of GST - Constitutional Amendments.	15
II	GST:Principles – Models of GST: Austrian, Canadian, Kelkar-Shah – BagchiPoddar -Comprehensive structure of GST model in India: Single, Dual GST– Transactions covered under GST.	15
III	Taxes and Duties: Subsumed under GST - Taxes and Duties outside the purview of GST: Tax on items containing Alcohol – Tax on Petroleum products - Tax on Tobacco products - Taxation of Services	15
IV	Inter-State Goods and Services Tax: Major advantages of IGST Model – Interstate Goods and Service Tax: Transactions within a State under GST – Interstate Transactions under GST - Illustrations	15
V	Time of Supply of Goods & Services: Value of Supply - Input Tax Credit – Distribution of Credit -Matching of Input Tax Credit - Availability of credit in special circumstances- Cross utilization of ITC between the Central GST and the State GST.	15

References:

1. Goods and Services Tax in India – Notifications on different dates.
2. GST Bill 2012.
3. Background Material on Model GST Law, Sahitya Bhawan Publications, Hospital Road, Agra - 282 003.
4. The Central Goods and Services Tax Act, 2017, NO. 12 OF 2017 Published by Authority, Ministry of Law and Justice, New Delhi, the 12th April, 2017.



A. G & S.G. SIDDHARTHA DEGREE COLLEGE OF ARTS & SCIENCE

Vuyyuru-521165.

**NAAC reaccredited at 'A' level
Autonomous -ISO 9001 – 2015 Certified**

TITLE OF THE PAPER: GOODS & SERVICE TAX FUNDAMENTALS

Semester: V

MODEL PAPER

TIME -3hrs

Max. Marks: 70

SECTION-A

I. Answer any TWO of the following

2x5=10M

1. What is GST?
2. Dual GST
3. Subsumed under GST
4. Central GST

SECTION-B

II. Answer any FOUR of the following

4x15=60M

5. What are the advantages of Goods and Services Tax
6. What is the Comprehensive Structure of GST in India?
7. Write about Australian Model of GST
8. Explain the Taxes and Duties outside the Purview of GST
9. What are the advantages of IGST?
10. Explain about interstate transactions under GST
11. What is Time supply of goods and services?
12. What is input tax credit and explain it with suitable examples.



A. G & S.G. SIDDHARTHA DEGREE COLLEGE OF ARTS & SCIENCE

Vuyyuru-521165.

NAAC recredited at 'A' level

Autonomous -ISO 9001 – 2015 Certified

TITLE OF THE PAPER: GOODS & SERVICE TAX FUNDAMENTALS

Semester: V

Guidelines to the paper setter

Marks	UNIT-I	UNIT-II	UNIT-III	UNIT-IV	UNIT-V
	Introduction	GST:Principles	Taxes and Duties	Inter-State Goods and Services Tax	Time of Supply of Goods & Services
5Marks	1	1	1	0	1
15Marks	1	2	1	2	2
Weight age	20	35	20	30	35



A. G & S.G. SIDDHARTHA DEGREE COLLEGE OF ARTS & SCIENCE

Vuyyuru-521165.

NAAC recredited at 'A' level
Autonomous -ISO 9001 – 2015 Certified

TITLE OF THE PAPER: Commercial Geography
Semester: V

Course Code	CCG-504G/C C	Course Delivery Method	Class Room / Blended Mode - Both
Credits	4	CIA Marks	30
No. of Lecture Hours / Week	5	Semester End Exam Marks	70
Total Number of Lecture Hours	75	Total Marks	100
Year of Introduction:	Year of Offering: 2021 - 22	Year of Revision: ----	Percentage of Revision: 0%
CLASS:	III B. Com(gen/comp)		

Course Objectives:

To identify the early commercial activities in the world reflecting different occupations in various environments.

To note, shift and change from primitive activities, and to understand the different stages of agricultural development.

COURSE OUTCOMES

CO1 Understand the importance of early commercial activities in the world reflecting different occupations in various environments.

CO2 Explain different stages of agricultural development using additional OE resources available in the internet using modern ICT tools.

CO3 Respond to the changes involved in the Indian forests and need for protection of forests and Forests Conservation Act.

CO4 Know different types of minerals India and mining and their uses.

CO5 Examine Indian water resources, Interlinking of Rivers India and Experience of India and Andhra Pradesh.

SYLLABUS

Commercial Geography

Course Details:

Unit	Learning Units	Lecture Hours
I	The Earth: Internal structure of the Earth – Latitude – Longitude – Realms of the Earth – Evolution of the Earth – Environmental pollution - Global Warming - Measures to be taken to protect the Earth.	15
II	India – Agriculture: Land Use - Soils - Major crops – Food and Non-food Crops – Importance of Agriculture – Problems in Agriculture – Agriculture Development.	15
III	India – Forestry: Forests – Status of Forests in Andhra Pradesh – Forest (Conservation) Act, 1980 – Compensatory Afforestation Fund (CAF) Bill, 2015 - Forest Rights Act, 2006 and its Relevance – Need for protection of Forestry.	15
IV	India – Minerals and Mining: Minerals – Renewable and non Renewable – Use of Minerals – Mines – Coal, Barites, etc. – Singareni Coal mines and Mangampeta Barites – Districtwise Profile.	15
V	India – Water Resources – Rivers: Water resources - Rationality and equitable use of water – Protection measures - Rivers - Perennial and peninsular Rivers - Interlinking of Rivers - Experience of India and Andhra Pradesh.	15

References:

1. Shabiar Ahmad; Quazi, Natural Resource Consumption and Environment Management, APH Publishing Corporation.
2. Tarachand, Economic and Commercial Geography of India, Vikas Publishing House.
3. Dr. S. Sankaran, Commercial Geography, Margam Publications, Chennai.
4. C. B. Memoria, Commercial Geography, Lal Agarwal & Co.



A. G & S.G. SIDDHARTHA DEGREE COLLEGE OF ARTS & SCIENCE

Vuyyuru-521165.

NAAC reaccredited at 'A' level

Autonomous -ISO 9001 – 2015 Certified

TITLE OF THE PAPER: Commercial Geography

Semester: V

Model paper

Time: 3 hrs

Max. Marks: 70

SECTION- A

I. Answer any Two of the following questions

2 x 5= 10M

1. Global warming
2. Non-food crops
3. Singareni Coal Mines
4. Krishna River

SECTION- B

II. Answer any FOUR of the following questions

4 x 15 = 60M

5. Explain the internal structure of the Earth
6. What are the measures to be taken to protect the Earth
7. Explain about different types of soils.
8. Explain forest conservation Act 1980.
9. Describe the need for protection of forests
10. Explain renewable and non renewable minerals
11. Explain the importance of interlinking of rivers
12. What are the problems facing by the farmers in India?



A. G & S.G. SIDDHARTHA DEGREE COLLEGE OF ARTS & SCIENCE

Vuyyuru-521165.

NAAC reaccredited at 'A' level

Autonomous -ISO 9001 – 2015 Certified

TITLE OF THE PAPER: Commercial Geography
Semester: V

Guidelines to the paper setter

	UNIT-I	UNIT-II	UNIT-III	UNIT-IV	UNIT-V
	The Earth	India- Agriculture	India-Forestry	India-Minerals and Mining	India-Water resources- Rivers
5 Marks questions	1	1	0	1	1
15 Marks questions	2	2	2	1	1
Weight age	35	35	30	20	20



A. G & S.G. SIDDHARTHA DEGREE COLLEGE OF ARTS & SCIENCE

Vuyyuru-521165.

NAAC reaccredited at 'A' level
Autonomous -ISO 9001 – 2015 Certified

TITLE OF THE PAPER: Central Banking
Semester: V

Course Code	CCB 505CE G/C	Course Delivery Method	Class Room / Blended Mode - Both
Credits	4	CIA Marks	30
No. of Lecture Hours / Week	5	Semester End Exam Marks	70
Total Number of Lecture Hours	75	Total Marks	100
Year of Introduction:	Year of Offering: 2021 - 22	Year of Revision: ----	Percentage of Revision: 0%
CLASS:	III B. Com(gen)		

Course Objectives:

To acquire basic knowledge about central bank functions and role of RBI in India

COURSE OUTCOMES

CO1: Students are able to impart concepts of central banking

CO2: Understand the role of RBI in India

CO3 Students can learn about policies issued by RBI.

CO4: Students will acquire the knowledge about RBI mechanism to control inflation

CO5: Students are able to learn norms issued by RBI

SYLLABUS
Central Banking

Course Details

Unit	Learning Units	Lecture Hours
I	Introduction: Evolution and Functions of Central Bank - Development of Central Banks in Developed and Developing countries - Trends in Central Bank Functions.	15
II	Central banking in India: Reserve Bank of India - Constitution and Governance, Recent Developments, RBI Act. - Interface between RBI and Banks.	15
III	Monetary and Credit Policies: Monetary policy statements of RBI - CRR - SLR – Repo Rates - Reverse Repo Rates - Currency in circulation - Credit control measures.	15
IV	Inflation and price control by RBI: Intervention mechanisms - Exchange rate stability -Rupee value - Controlling measures.	15
V	Supervision and Regulation: Supervision of Banks - Basle Norms, Prudential Norms, Effect of liberalization and Globalization - Checking of money laundering and frauds.	15

References:

1. Reserve Bank of India Publication, Functions and Working of the RBI.
2. Vasant Desai, Central Banking and Economic Development, Himalaya Publishing.
3. S. Panandikar, Banking in India, Orient Longman.
4. Reserve Bank of India Publication, Report on Trends and Progress of Banking in India.
5. Annual Reports of Reserve Bank of India.
6. Rita Swami, Indian Banking System, International Publishing House Pt. Ltd..



A. G & S.G. SIDDHARTHA DEGREE COLLEGE OF ARTS & SCIENCE

Vuyyuru-521165.

NAAC reaccredited at 'A' level

Autonomous -ISO 9001 – 2015 Certified

TITLE OF THE PAPER: Central Banking
Semester: V

Model paper
Central Banking

Time: 3 hrs

Max. Marks: 70

SECTION- A

I. Answer any TWO of the following questions

2 x 5= 10M

1. Evolution of Central Bank
2. RBI Act 1934
3. Statutory liquidity Ratio
4. Exchange Rate

SECTION- B

II. Answer any FOUR of the following questions

4 x 15 = 60M

5. Describe the functions Central Bank.
6. Explain the differences between RBI and Commercial banks
7. State the Role of RBI in Economic Development
8. What are the various weapons of credit control available to RBI
9. What is Cash Reserve Ratio? Explain its importance
10. Bring out Clearly the Exchange Control Function of the RBI
11. Explain Basle Norms and Prudential Norms.
12. Explain the Checking of Money laundering and frauds.



A. G & S.G. SIDDHARTHA DEGREE COLLEGE OF ARTS & SCIENCE

Vuyyuru-521165.

NAAC reaccredited at 'A' level

Autonomous -ISO 9001 – 2015 Certified

TITLE OF THE PAPER: Central Banking

Semester: V

Guidelines to the paper setter

Marks	UNIT-I	UNIT-II	UNIT-III	UNIT-IV	UNIT-V
	Introduction	Central banking in India	Monetary and Credit policies	Inflation and price control by RBI	Supervision and Regulation
5Marks	1	1	1	1	0
15Marks	1	2	2	1	2
Weight age	20	35	35	20	30



A. G & S.G. SIDDHARTHA DEGREE COLLEGE OF ARTS & SCIENCE

Vuyyuru-521165.

NAAC reaccredited at 'A' level
Autonomous -ISO 9001 – 2015 Certified

TITLE OF THE PAPER: Rural and Farm Credit
Semester: V

Course Code	CRC-506 CE G/C	Course Delivery Method	Class Room / Blended Mode - Both
Credits	4	CIA Marks	30
No. of Lecture Hours / Week	5	Semester End Exam Marks	70
Total Number of Lecture Hours	75	Total Marks	100
Year of Introduction:	Year of Offering: 2021 - 22	Year of Revision: ----	Percentage of Revision: 0%
CLASS:	III B. Com(gen)		

Course Objectives:

To acquire basic knowledge about rural development and empowerment of farming community by banks,

Students are able solve simple problems through case study of Farm Credit

COURSE OUTCOMES

CO1: Students are able to impart knowledge about concepts of rural credit

CO2: Students are able to impart knowledge about rural credit agencies

CO3 Students can acquire knowledge problems and remedies of Farm Credit

CO4: Students are able to impart knowledge about sources of farm credit

CO5: Students able to learn norms issued by RBI

SYLLABUS
Rural and Farm Credit

Course Details

Unit	Learning Units	Lecture Hours
I	Rural Credit: Objectives and Significance of Rural credit - Classification of rural credit -General Credit Card (GCC) – Financial Inclusion - Rupay Card.	15
II	Rural Credit Agencies: Institutional and Non-institutional Agencies for financing agriculture and Rural development - Self-Help Groups (SHG) - Financing for Rural Industries.	15
III	Farm Credit: Scope - Importance of farm credit - Principles of Farm Credit - Types- Cost of Credit - - problems and remedial measures - Kisan Credit Card (KCC) Scheme	15
IV	Sources of Farm Credit: Cooperative Credit: PACS - APCOB - NABARD SLBC- Lead Bank Scheme - Role of Commercial and Regional Rural Banks - Problems of recovery and over dues.	15
V	Farm Credit Analysis: Eligibility Conditions - Analysis of 3 R's (Return, Repayment Capacity and Risk-bearing Capacity) - Analysis of 3 C's of Credit (Character, Capacity and Capital) - Crop index reflecting use and farm credit - Rural Credit Survey Reports..	15

References:

1. National Bank of Agricultural and Rural Development (NABARD) Annual report.
2. Economic Survey, Government of India.
3. Rural Development, Sundaram I.S., Himalaya Publishing House, Mumbai.
4. Rural Credit in India, C.S.Rayudu, Mittal Publications.
5. Farm Credit and Co-operatives in India, Tiruloati V., Naidu. V T Naidu, Vora & Co. Pub. Ltd.

Project Work: Rural Credit survey/Banking operations/Credit Appraisal



A. G & S.G. SIDDHARTHA DEGREE COLLEGE OF ARTS & SCIENCE

Vuyyuru-521165.

NAAC recredited at 'A' level
Autonomous -ISO 9001 – 2015 Certified

TITLE OF THE PAPER: Rural and Farm Credit
Semester: V

Model paper

Time: 3 hrs

Max. Marks: 70

SECTION- A

I. Answer any TWO of the following questions

2x 5= 10M

1. Rural Credit
2. Self Help Groups
3. Kisan Credit Card
4. Repayment Capacity

SECTION- B

II. Answer any FOUR of the following questions

4 x 15 = 60M

5. Describe the significance of Rural Credit
6. Explain Classification of Rural Credit
7. What are Institutional agencies for Financing Agricultural?
8. Explain advantages and disadvantages of Self-Help Groups
9. Explain the principles of Farm Credit
10. Write about NABARD
11. Explain the role of Regional Rural Banks in Farm Credit
12. What is the Analysis of 3C'S of Credit?



**A. G & S.G. SIDDHARTHA DEGREE COLLEGE
OF ARTS & SCIENCE**

Vuyyuru-521165.

NAAC reaccredited at 'A' level
Autonomous -ISO 9001 – 2015 Certified

TITLE OF THE PAPER: Rural and Farm Credit
Semester: V

Guidelines to the paper setter

Marks	UNIT-I	UNIT-II	UNIT-III	UNIT-IV	UNIT-V
	Rural Credit	Rural Credit Agencies	Farm Credit	Sources of Farm Credit	Farm Credit Analysis
5Marks	1	1	1	0	1
15Marks	2	2	1	2	1
Weight age	35	35	20	30	20

AG & SG SIDDHARTHA DEGREE COLLEGE OF ARTS & SCIENCE VUYYURU

(AUTONOMOUS)

(MANAGED BY SIDDHARTHA ACADEMY OF GENERAL & TECHNICAL EDUCATION VIJAYAWADA)



PG Department of Commerce

Minutes of the meeting of Board of Studies

30-11-2021



AG&SG S DEGREE COLLEGE OF ARTS AND SCIENCE
VJAYAWADA-10

(An Autonomous college under the jurisdiction of Krishna University)
Reaccredited at the level 'A+' by the NAAC

DEPARTMENT OF COMMERCE

Minutes of Board of Studies Meeting (Online) of Department of Commerce for M.Com held on 29/11/2021, Monday at 11.30 AM. The following members were present.

Members Present		
Name of the Member	Role	Signature
Dr. T.Venkateswara Rao HOD Department of Commerce Mobile No: 9848726150/9491737921	Chairman	
Dr. R. Padmaja, Assistant Professor in Business Management, Krishna University, Machilipatnam. Mobile: 9440532444,	University Nominee	
Dr.R. Siva Ram Prasad. Santha Kumari, Professor, Dean Department of Commerce & Business Administration Acharya Nagarjuna University, Nagarjuna Nagar, Guntur Mobile No: 9849856589	Subject Expert	
Prof. Rajesh C Jampala Dean Department of Commerce & Business Management PBS College of Arts & Science, Vijayawada. Mobile No: 9866806069	Subject Expert	
Sai Babu, Vuyyuru	Alumnus	
Sri V.V. Punna Rao General Manager KCP Sugar Pvt., Ltd, Vuyyuru. Mobile No: 9704456972	Industry Expert	
Kum Mohana Krishna Department of Commerce (PG) AG&SGS Degree College of Arts & Science, Vuyyuru	Member	
Y. Swarna Latha Department of Commerce (PG) AG&SGS Degree College of Arts & Science,	Member	
G. Kiran Kumar Department of Commerce (PG) AG&SGS Degree College of Arts & Science, Vuyyuru	Member	

Agenda for Board of Studies meeting for the

Master of Commerce (M.Com)

PG Department of Commerce

To evaluate and recommend Programme Structure for Master of Commerce program (M.Com) under CBCS for the students admitted in the academic year 2021-22.

1. To explore the possibility of new courses or combination of courses.
2. To assess the potential of the courses against the employment prospects.
3. To assess the compatibility of practical courses with theory courses.
4. To approve the structure of Model Question Papers with COs and levels of Bloom's taxonomy for all courses of I&III semesters of M.Com.
5. To approve the list of examiners and paper setters of all the courses.
6. To approve the course outcomes (COs) for all the courses of I & III (ODD) Semesters of M.Com.
7. Any other matter with the permission of the chair.

RESOLUTIONS

1. Discussed and recommended the syllabi of I and III semester of M.Com, for the approval of the Academic Council.
2. Discussed and recommended **Dual Specialisation in 1. Accounting & Taxation 2. Banking, Insurance & Finance** for III semester of M.Com, for the approval of the Academic Council.
3. Discussed and recommended to replace the 'Unit-V' of 'Information Technology for Business' by MS Office (Advanced).
4. Discussed and recommended the Elective Paper 'TALLY with GST' with Lab facility.
5. Discussed and recommended the Lab facility for III Semester Students for e-filing, visiting Web-sites to acquire the knowledge about Stock Markets, Mutual Funds etc.
6. Discussed and recommended the Open Elective Paper for Non-commerce Post Graduates 'Basics of Financial Literacy' about Investments and Stock Markets.
- 7.
8. Discussed and recommended the Model Question Papers of I and III Semesters of M.com., for the approval of the Academic Council.
9. Discussed and recommended the guidelines to be followed by the question paper setter of M.com I and III semesters. For the approval of the Academic Council.
10. Discussed and recommended the following teaching and evaluation methods for the approval of Academic Council.

Teaching Methods:

Besides the conventional methods of teaching, we use modern technology i.e., using of LCD projector to display on U boards and online teaching etc., for better understanding of concept.

Evaluation of student is done by the following procedure:

- i. Out of maximum 100 marks in each paper, 30 marks shall be allocated for internal assessment.
- ii. Out of 30 marks, 20 marks are allocated for announced internal tests. Four announced internal tests will be conducted and average of these Four tests shall be deemed as the marks obtained by the students, out of 10 marks 5 marks are allocated to assignments and seminars and remaining 5 marks are allocated to candidate's percentage of attendance.

Semester-End Examinations:

- i. The maximum marks for Semester-End Examinations shall be 70 marks and duration of the examination shall be 3 Hours.
- ii. Semester-End Examinations shall be conducted in theory papers at the end of every Semester.

11. Discussed and recommended for organising National seminars, Guest Lectures, Work-shops to upgrade the knowledge of students, for the approval of the Academic Council.
12. Discussed and empowered the H.O.D. to suggest the panel of paper setters and Examiners to the Controller of Examinations.

CHAIRMAN

M.Com:

PSOs:

PSO1: To provide an opportunity for graduates to acquire theoretical as well as practical inputs in commerce to enter a career in professional areas of commerce and finance such as taxation, consultancy and financial services.

PSO2: To develop advanced theoretical knowledge and research capabilities to be able to pursue academic and research focused careers.

POs:

PO1: Business Environment and Domain Knowledge (BEDK): Economic, legal and social environment of Indian business. Graduates are able to improve their awareness and knowledge about functioning of local and global business environment and society. This helps in recognizing the functioning of businesses, identifying potential business opportunities, evolution of business enterprises and exploring the entrepreneurial opportunities.

PO2: Critical thinking, Business Analysis, Problem Solving and Innovative Solutions (CBPI): Competencies in quantitative and qualitative techniques. Graduates are expected to develop skills on analyzing the business data, application of relevant analysis, and problem solving in other functional areas such as marketing, business strategy and human resources.

PO3: Global Exposure and Cross-Cultural Understanding (GECCU): Demonstrate a global outlook with the ability to identify aspects of the global business and Cross Cultural Understanding.

PO4: Social Responsiveness and Ethics (SRE): Developing responsiveness to contextual social issues/ problems and exploring solutions, understanding business ethics and resolving ethical dilemmas. Graduates are expected to identify the contemporary social problems, exploring the opportunities for social entrepreneurship, designing business solutions and demonstrate ethical standards in organizational decision making. Demonstrate awareness of ethical issues and can distinguish ethical and unethical behaviors.

PO5: Effective Communication (EC): Usage of various forms of business communication, supported by effective use of appropriate technology, logical reasoning, articulation of ideas. Graduates are expected to develop effective oral and written communication especially in business applications, with the use of appropriate technology (business presentations, digital communication, social network platforms and so on).

PO6: Leadership and Teamwork (LT): Understanding leadership roles at various levels of the organization and leading teams. Graduates are expected to collaborate and lead teams across organizational boundaries and demonstrate leadership qualities, maximize the usage of diverse skills of team members in the related context.

PO7: Knowledge Application (KA): Acquire knowledge in different areas of management such as finance, marketing, accounting, human resource and operations and apply

quantitative techniques such as operations research, statistical methods, financial models, econometrics for making informed business decisions in organizations

APPENDIX – I

Scheme of Instruction and Evaluation for **M.Com.**, Programme for the batch of students admitted during 2021-'22 and onwards.

Course Code	Title of the Course	Instruction Hours per week			Credits	Evaluation		
		L	T	P		CIA MARKS	SEE	
							MARKS	DURATION
SEMESTER – I								
CO111	Management Theory & Practice	4	1	1	4	30	70	3 Hrs.
CO112	Business Economics	4	1	1	4	30	70	3 Hrs.
CO113	Business Environment	4	1	1	4	30	70	3 Hrs.
CO114	Entrepreneurship Development & Business Models	4	1	1	4	30	70	3 Hrs.
CO115	Information Technology for Business	4	1	1	4	30	70	3 Hrs.
CO116	Quantitative Techniques for Business Decisions	4	1	1	4	30	70	3 Hrs.

III SEMESTER

Course Code	Title of the Course	Instruction Hours per week			Credits	Evaluation		
		L	T	P		CIA MARKS	SEE	
							MARKS	DURATION
Generic core course								
CO311	Business Communication Skills	4	1	1	4	30	70	3 Hrs.
CO312	Financial Institutions & Markets	4	1	1	4	30	70	3 Hrs.
FUNCTIONAL SPECIALISATIONS								
From the following three specialization areas choose any two elective courses each from two specialization areas of your choice :								
1. Accounting & Taxation 2. Banking, Insurance & Finance 3. International Business								
Accounting & Taxation								
CO321	Advanced Cost Accounting	4	1	1	4	30	70	3 Hrs.
CO322	Corporate Accounting	4	1	1	4	30	70	3 Hrs.
CO323	Direct Taxes	4	1	1	4	30	70	3 Hrs.
CO324	Management Control System	4	1	1	4	30	70	3 Hrs.
Banking, Insurance & Finance								
CO331	Security Analysis & Portfolio Management	4	1	1	4	30	70	3 Hrs.
CO332	Bank Management	4	1	1	4	30	70	3 Hrs.
CO333	Export Finance	4	1	1	4	30	70	3 Hrs.
CO334	Insurance Products and Management	4	1	1	4	30	70	3 Hrs.
International Business								
CO341	International Business Environment	4	1	1	4	30	70	3 Hrs.
CO342	International Accounting	4	1	1	4	30	70	3 Hrs.
CO343	International Financial Management	4	1	1	4	30	70	3 Hrs.
CO344	International Business Law & Taxation	4	1	1	4	30	70	3 Hrs.
Generic Elective Courses(Choose any one out of three courses)								
GE04	Fundamentals of Goods & Service Tax	1	1	1	2	50	-	
GE05	Soft and Employability Skills	1	1	1	2	50	-	
GE06	MOOCS: NPTEL/SWAYAM/edX/Coursera/Stanford Online/Udacity/ OpenClassrooms/ Open2Study/ ALISON/ Khan Academy/ NSE-NCFM/IRDA/NISM/ Any course related to MBA from the authentic sources with prior permission.	1	1	1	2	50	-	
CO351	Project Work	-	-	-	2	50	-	



A. G & S.G. SIDDHARTHA DEGREE COLLEGE OF ARTS & SCIENCE

Vuyyuru-521165.

NAAC reaccredited at 'A' level

Autonomous -ISO 9001 – 2015 Certified

TITLE OF THE PAPER: MANAGEMENT THEORY AND PRACTICE

Semester: I

CO111: MANAGEMENT THEORY AND PRACTICE (4L + 1T + 1P)

Course Code	CO111	Course Delivery Method	Class Room / Blended Mode - Both
Credits	4	CIA Marks	30
No. of Lecture Hours / Week	5	Semester End Exam Marks	70
Total Number of Lecture Hours	75	Total Marks	100
Practical Component	01 Hour/Week	Exam Hours	03
Year of Introduction:	Year of Offering: 2021 - 22	Year of Revision: ----	Percentage of Revision: 0%
CLASS:	1 M.Com		

Course Outcomes:

- CO-1 To provide knowledge and understanding of the Principles of Management will enable the students gain valuable insight into the workings of business and other organizations.
- CO-2 To enable the students understand the managerial functions and practices of various
- CO-3 To make the students understand elements of organizing and staffing.
- CO-4 To evaluate the influence of effective communication, motivation and leadership
- CO-5 To understand the significance of managerial control and formulate best control methods.

MANAGEMENT THEORY AND PRACTICE

Unit–I: Introduction: Management, Concept, Significance, Levels, Skills, Functions and Principles - Management as an Art, Science and Profession – Social responsibilities of business.

Unit–II: Planning: Nature, Purpose, Process of Planning, Types of Plans – Premising & Forecasting, Decision Making: Concept, Process, Management By Objectives: Concepts, Process. Advantages and Limitations.

Unit–III: Organizing: Process - Formal and Informal Organizations -Departmentation: Methods of Departmentation, Span of Control; V.A. Graicuna’s Theory - Factors Determining Span of Control - Delegation: Concept, Process, Advantages and Principles of Effective Delegation; Decentralization: Factors, Advantages and Disadvantages. Line and Staff: Concept- Reasons for Conflicts between Line and Staff and Measures to Overcome; Committees, Types of Committees.

Unit–IV: Staffing: Nature and Importance of Staffing, Elements of Staffing. Directing: Meaning, Assumptions of Human Behavior by Douglas McGregor, Edgar Shien and Elton Mayo.

Unit–V: Motivation: Significance, Process-Theories of Maslow, Herzberg, Porter and Lawler; Leadership: Trait Approach, Leadership Styles, Managerial Grid; Likert’s Four Systems of Leadership- Communication: Importance, Process, Barriers, Measures to overcome Barriers of an Effective Communication. Controlling: Basis - Control Process, Requirements of adequate Control - Techniques of control, PERT and CPM.

Note: *Bold Content can be delivered online

Suggested Books:

- Heinz Wihrich., H.Koontz and Markv Cannice, *Management*, 13ed. 2010, Tata McGraw, New Delhi
- Prasad L.M, Principles and Practice of Management, Edition2019, Sultan Chand and Sons, New Delhi.
- Rama Swamy T, Principles of Management. First Ed.,2014, Himalaya Publishing House, Mumbai.
- Stoner, J. *Management*, 6th ed., 1995, Pearson Education, New Delhi.

The Guidelines to be followed by the question paper setters in

MANAGEMENT THEORY AND PRACTICE for the first semester-end exams

PAPER TITLE: MANAGEMENT THEORY AND PRACTICE

PAPER-1 Semester-1 Maximum Marks: 70 Duration: 3 Hours

Weightage for the question paper

syllabus	Section –A (short answer questions) (with internal choice)	Section- B (Long answer questions) (with internal choice)	Section –C (essay question) (with internal choice)
Unit -1	1 (a or b)	1 (a or b)	Any unit
Unit -2	1 (a or b)	1 (a or b)	
Unit -3	1 (a or b)	1 (a or b)	
Unit -4	1 (a or b)	1 (a or b)	
Unit -5	1 (a or b)	1 (a or b)	

- Each short answer question carries 4 marks in section-A.
- Each long answer question carries 8 marks in section-B.
- Each essay answer question carries 10 marks in section-C.

The Question Paper Setters are requested to cover all the topics in the syllabus stipulated as per the weightage given by us.

MODEL QUESTION PAPER
M.COM. (REGULAR) DEGREE EXAMINATION
First Semester
MANAGEMENT THEORY AND PRACTICE
(2021-22 Regulation Onwards)

Duration: 3 hours

Maximum Marks: 70

SECTION- A

1. Answer All Questions

5×4=20 Marks

- i. a) Concept of management (CO1)(L1) OR
b) Skills of management (CO1)(L1)
- ii. a) Explain the purpose of Planning (CO2)(L2) OR
b) Distinguish between the concepts Delegation and Decentralization.(CO2) (L4)
- iii. a) Classify the types of Committees.(CO3)(L2) OR
b) Define Departmentation .(CO3)(L1)
- iv. a) Define Staffing. (CO4)(L1) OR
b) Explain Executive Development Programme (CO4)(L2)
- v. a) Show the list of Leadership Traits.(CO5) (L2) OR
b) Define PERT AND CPM.(CO5)(L1)

SECTION – B

Answer All Questions

5×8=40Marks

- 2. a) Explain the Nature and significance of Management.(CO1)(L2)
(Or)
b) Discuss the functions of Management.(CO1)(L3)
- 3. a) Define MBO. Explain the steps in MBO process.(CO2)(L2)
(Or)
b) Describe steps in the process of Planning.(CO2)(L2)
- 4. a) Examine the methods of Departmentation with merit and limitations of each.(CO3)
(L3)
(Or)
b) Define Span of Management. Analyze determining factors that influence span of
management. (CO3)(L4)
- 5. a) Identify the nature and elements of staffing.(CO4)(L4)
(Or)
b) Distinguish between theory X and theory Y proposed by McGregor.(CO4)(L4)
- 6. a) Examine the motivation theory of Need Hierarchy.(CO5)(L4)
(Or)
b) Define Leadership. Categorize the Styles of leadership(CO5)(L4)

SECTION C - (1 x 10=10 marks)

Answer the following question.

7. **a)** Define Management. Explain the 14 principles of management as given by Henry Fayol.(CO1)(L4)

(Or)

- b)** Define Communication. Analyze various barriers to effective communication. Suggest measures to make communication more effective(CO5)(L4)



A. G & S.G. SIDDHARTHA DEGREE COLLEGE OF ARTS & SCIENCE

Vuyyuru-521165.

NAAC reaccredited at 'A' level

Autonomous -ISO 9001 – 2015 Certified

TITLE OF THE PAPER: BUSINESS ECONOMICS

Semester: I

Course Code	CO112	Course Delivery Method	Class Room / Blended Mode - Both
Credits	4	CIA Marks	30
No. of Lecture Hours / Week	5	Semester End Exam Marks	70
Total Number of Lecture Hours	75	Total Marks	100
Practical Component	01 Hour/Week	Exam Hours	03
Year of Introduction:	Year of Offering: 2021 - 22	Year of Revision: ----	Percentage of Revision: 0%
CLASS:	1 M.Com		

Course Outcomes:

- CO-1 To outline expert knowledge about the concept of managerial economics, to analyze the students to understand the concepts of demand, utility and demand forecasting.
- CO-2 To Organize an insight in the basic features of production and cost function.
- CO-3 To explain the students to familiarize with different market structures and its importance
- CO-4 To experiment impart knowledge on the concepts of pricing and pricing policy.
- CO-5 To understand Pricing Practices of Firms

BUSINESS ECONOMICS

Unit-I: Introduction – Definition, Nature and Scope of Managerial Economics; Economic Goals of a Business Firm: Profit Maximization Vs Wealth Maximization, Sales Revenue Maximization.

Unit-II: Consumer Equilibrium under Cardinal and Ordinal Utility - Demand Analysis – Law of Demand – Demand Function and determinants of Market Demand – Concept of Price, Cross, Income and Promotional Elasticity; their measurement and relevance in Managerial Decision – Making Methods of Demand Forecasting.

Unit-III: Firm’s Equilibrium – Iso-quant and Iso-cost analysis; Least – Cost Combination of inputs – The law of Diminishing Marginal Returns in Production – Production Function – Total Product, Marginal and Average Product Curves, their inter – relationships – Cobb – Douglas Production Function and its relevance - Scale and proportion, Cost Functions – Derivation of total, marginal and average cost functions – Long run cost curves

Unit-IV: Market Structures and their characteristics – Pricing and output Decisions of firm under different Market structures – Perfect Competition, Pure Monopoly, Oligopoly, Monopolistic / Imperfect Competition under short and long runs. Discriminative Monopoly Regulation of Monopoly through Prices and Taxes.

Unit-V: Pricing Practices of Firms – Objectives of Pricing Policy – Approaches to Pricing New Products; Skimming Price, Penetration Pricing, Costs Plus Pricing, Managerial Cost Pricing, Psychological Pricing, Odd Number Pricing, Regulated Pricing, Predatory Pricing.

Note: * Bold Content can be delivered online

Suggested Books

- Gauvrav Datt and Ashwani Mahajan, Indian Economy. 5th Ed, 2015, S Chand and Co, New Delhi.
- Mithani DM, Managerial Economics-Theory and Applications,5th Ed,2010,Himalaya publishing house ,Mumbai.
- Thomas R, Christopher Charles, Maurice, “Managerial Economics: Concepts and .Applications”, 4th 2012, Tata McGraw-Hill, New Delhi..
- Sudip Chaudhuri, Anindya Sen, Economics,19th Ed,2016,Tata Mc Grail Education Pvt Ltd, New Delhi.

The Guidelines to be followed by the question paper setters in BUSINESS ECONOMICS for the first semester-end exams

PAPER TITLE: BUSINESS ECONOMICS

PAPER-2 Semester-1 Maximum Marks: 70 Duration: 3 Hours

Weightage for the question paper

syllabus	Section –A (short answer questions) (with internal choice)	Section- B (Long answer questions) (with internal choice)	Section –C (essay question) (with internal choice)
Unit -1	1 (a or b)	1 (a or b)	Any unit
Unit -2	1 (a or b)	1 (a or b)	
Unit -3	1 (a or b)	1 (a or b)	
Unit -4	1 (a or b)	1 (a or b)	
Unit -5	1 (a or b)	1 (a or b)	

- Each short answer question carries 4 marks in section-A.
- Each long answer question carries 8 marks in section-B.
- Each essay answer question carries 10 marks in section-C.

The Question Paper Setters are requested to cover all the topics in the syllabus stipulated as per the weightage given by us.

MODEL QUESTION PAPER
M.COM. (REGULAR) DEGREE EXAMINATION
First Semester
BUSINESS ECONOMICS
(2021-2022 Regulation Onwards)

Duration: 3 hours

Maximum Marks: 70

SECTION- A

1. Answer All Questions

5×4=20 Marks

- i. a) Define Wealth maximization.(CO1)(L1) or
b) Distinguish Business Economics from Managerial Economics .(CO1)(L4)
- ii. a) Explain Demand function.(CO2)(L2) or
b) Explain Consumer Equilibrium (CO2)(L2)
- iii. a) What is Marginal cost.(CO3)(L1) or
b) Explain Cobb-Douglas production function. (CO3)(L2)
- iv. a) Define Perfect competition.(CO4)(L1) or
b) Define Oligopoly .(CO4)(L1)
- v. a) Explain Penetration Pricing.(CO5)(L2) or
b) Analyse Good value strategy.(CO5)(L4)

SECTION – B

Answer All Questions

5×8=40Marks

2. a) Define Business economics? Discuss its nature and scope? (CO1)(L1)
(OR)
b) What are the economic goals of a firm? (CO1)(L1)
3. a) What is the meaning of Demand? What are the determinants of market demand?
(CO1)(L1)
(OR)
b) Explain about the income elasticity of demand with some examples? (CO1)(L2)
4. a) Examine the firm's equilibrium using ISOCOST and ISOQUANT
analysis? (CO1)(L4)
(OR)
b) Explain the managerial uses of cost concepts? (CO1)(L2)
5. a) Distinguish between perfect competition and monopolistic competition? (CO1)(L4)
(OR)
b) Explain the features of oligopoly? (CO1)(L2)
6. a) Examine briefly about objectives of pricing policy? (CO1)(L4)
(OR)
b) Outline in detail about cost plus pricing and managerial cost pricing? (CO1)(L2)

SECTION C - (1 x 10=10 marks)

Answer the following question.

7. a) Discuss how price determined under perfect competitive market? (CO1)(L6)
(OR)
b) Explain the cost output relationships both in short-run and long-run? (CO1)(L2)



A. G & S.G. SIDDHARTHA DEGREE COLLEGE OF ARTS & SCIENCE

Vuyyuru-521165.

NAAC reaccredited at 'A' level

Autonomous -ISO 9001 – 2015 Certified

TITLE OF THE PAPER : BUSINESS ENVIRONMENT

Semester: I

Course Code	CO113	Course Delivery Method	Class Room / Blended Mode - Both
Credits	4	CIA Marks	30
No. of Lecture Hours / Week	5	Semester End Exam Marks	70
Total Number of Lecture Hours	75	Total Marks	100
Practical Component	01 Hour/Week	Exam Hours	03
Year of Introduction:	Year of Offering: 2021 - 22	Year of Revision: ----	Percentage of Revision: 0%
CLASS:	1 M.Com		

Course Outcomes:

- CO-1 To understand the concept of business and elements of business environment.
- CO-2 To explain the effects of government policy on the economic environment of business.
- CO-3 To improve the ability to recognize and manage legal risks in business decision making.
- CO-4 To understand and appreciate the social aspects of business.
- CO-5 To develop an idea of international environment and recent issues in environment.

BUSINESS ENVIRONMENT

Unit-I: Business Environment: Components and Significance - Nature of Business Environment - Techniques of Environmental Scanning and Monitoring – **Economic Scope – Cultural, Political, Technological and External Factors Influencing Business Environment –Challenges- Economic systems.**

Unit-II: Economic Environment of Business: Significance for Business – Economic Planning – Objectives and Achievements; Government policies – Industrial policy of 1991; Fiscal policy; **Economic Reforms and LPG**

Unit-III: Political and Legal Environment of Business: Political Institutions – Legislature, Executive and Judiciary – Changing Dimensions of Legal Environment in India; **Patents Act-1970, SICA-1985, SEZ Act-2005.**

Unit-IV: Cultural and Technological Environment: Elements of Socio – Cultural Environment; Impact on Business – Social Audit - Technological Environment in India; Technology Transfer – Technology Policy.

Unit -V: International and Recent Issues in Environment: Multinational Corporations; Foreign Collaborations and Indian Business; International Economic Institutions: **WTO, World Bank, IMF and their importance to India;** Foreign Trade Policies.

NOTE: * BOLD CONTENT CAN BE DELIVERED ONLINE

Suggested Books

1. Francis Cherunilam, *Business Environment*, 25th revised edition 2017, Himalaya Publishing House, Mumbai.
2. Fernando, A.C., *Business Environment*, 1st edition 2011, Pearson, Delhi.
3. Suresh Bedi, *Business Environment*, 1st edition 2005, Excel Books, New Delhi,
4. Adhikary.M. *Economic Environment of Business*, 2004, Sultan Chand & Sons, New Delhi.
5. Aswathappa.K. *Essentials of Business Environment*, 12th revised edition 2014, Himalaya Publishing, Delhi.
6. Justin Paul, *Business Environment*, Text and Cases, 12th edition 2018, Tata McGraw Hill.
7. H.L.Ahuja, *“Economic Environment of Business”*, 13th edition 2016, S.Chand, New Delhi.

The Guidelines to be followed by the question paper setters in BUSINESS ENVIRONMENT for the first semester-end exams

PAPER TITLE: BUSINESS ENVIRONMENT

PAPER-3 Semester-1 Maximum Marks: 70 Duration: 3 Hours

Weightage for the question paper

Syllabus	Section –A (short answer questions) (with internal choice)	Section- B (Long answer questions) (with internal choice)	Section –C (essay question) (with internal choice)
Unit -1	1 (a or b)	1 (a or b)	Any unit
Unit -2	1 (a or b)	1 (a or b)	
Unit -3	1 (a or b)	1 (a or b)	
Unit -4	1 (a or b)	1 (a or b)	
Unit -5	1 (a or b)	1 (a or b)	

- Each short answer question carries 4 marks in section-A.
- Each long answer question carries 8 marks in section-B.
- Each essay answer question carries 10 marks in section-C.

The Question Paper Setters are requested to cover all the topics in the syllabus stipulated as per the weightage given by us.

MODEL QUESTION PAPER
M.COM. (REGULAR) DEGREE EXAMINATION
First Semester
BUSINESS ENVIRONMENT
(2021-2022 Regulation Onwards)

Duration: 3 hours

Maximum Marks: 70

SECTION- A

1. Answer All Questions

5×4=20 Marks

- i. a) Define Concept of Environment (CO1)(L1) or
b) Explain Business Environment Scanning (CO1)(L2)
- ii. a) Examine the Significance of Economic Environment of Business(CO2)
(L4) or
b) Define LPG (CO2) (L1)
- iii. a) Define Political Institutions (CO3) (L1) or
b) Define Legal Environment in India (CO3) (L1)
- iv. a) Define Cultural Environment (CO4) (L1) or
b) Define Technological Policy (CO4) (L1)
- v. a) Define Foreign Collaboration(CO5) (L1) or
b) Define WTO(CO5) (L1)

SECTION – B

Answer All Questions

5×8=40Marks

2. (a) Define Business Environment? Explain the nature and significance of Business Environment? (CO1) (L1)

(OR)

(b) Explain various techniques of environmental scanning? (CO1) (L2)
3. (a) What is economic planning? Explain the objectives of present economic plan? (CO2) (L1)

(OR)

(b) Critically examine the new industrial policy resolutions? (CO2) (L4)
4. (a) Define the political institutions? Explain the role of Government towards Business. (CO3) (L1) (L2)

(OR)

(b) Identify the role of SEZ act 2005 in the present context? (CO3) (L3)
5. (a) Explain the elements of socio-cultural elements? (CO4) (L2)

(OR)

(b) Discuss the importance of technological environment in India? (CO4) (L6)
6. (a) Define MNC? Explain the scope and importance of MNC? (CO5) (L1)(L2)

(OR)

(b) Determine the role of IMF in India? (CO5) (L5)

SECTION C - (1 x 10=10 marks)

Answer the following question.

7. (a) Define privatization? Explain the merits and demerits of privatization? (CO3)(L1)(L2)
(OR)
(b) Why WTO replaced GATT - Impact of Regional Trading Agreement on WTO?
(CO5) (L1)



A. G & S.G. SIDDHARTHA DEGREE COLLEGE OF ARTS & SCIENCE

Vuyyuru-521165.

NAAC reaccredited at 'A' level

Autonomous -ISO 9001 – 2015 Certified

TITLE OF THE PAPER: ENTREPRENEURSHIP DEVELOPMENT & BUSINESS MODELS

Semester: I

Course Code	CO114	Course Delivery Method	Class Room / Blended Mode - Both
Credits	4	CIA Marks	30
No. of Lecture Hours / Week	5	Semester End Exam Marks	70
Total Number of Lecture Hours	75	Total Marks	100
Practical Component	01 Hour/Week	Exam Hours	03
Year of Introduction:	Year of Offering: 2021 - 22	Year of Revision: ----	Percentage of Revision: 0%
CLASS:	1 M.Com		

Course Outcomes:

- CO-1 To understand the concept of Entrepreneurship and role of women entrepreneurs.
- CO-2 To know the importance of ideas in entrepreneurship and the ability to assess business potentiality of ideas.
- CO-3 To know the need for financial planning and preparation of business plans.
- CO-4 To analyze various business models in the emerging scenario.
- CO-5 To provide insights of business excellence models.

ENTREPRENEURSHIP DEVELOPMENT & BUSINESS MODELS

UNIT-I:

Entrepreneur: Evolution, Characteristics, Types, Functions of Entrepreneur - Factors influencing entrepreneurship - Barriers to entrepreneurship - Growth of Entrepreneurship in India - **Women entrepreneurship in India - Role of Entrepreneurship in Economic Development**

UNIT-II:

Idea Generation and Opportunity Assessment: Importance of Ideas in Entrepreneurship - Sources of New Ideas – Techniques for generating ideas- Steps in assessing business potential of an idea- **Opportunity Recognition- sources and process- Steps in tapping opportunity.**

UNIT-III:

Financing Of Enterprises: Need for Financial Planning- Sources of finance, Capital Structure, Term-loan, - Sources of Short-Term Finance, Venture capital, Export Finance,- **Institutional Finance To Entrepreneurs, - Preparation of Business Plans.**

UNIT-IV:

Business Model: Definition — **Generating a business model** – Nine building blocks of a canvas (Value Propositions; Key Activities; Key Partners; Key Resources; Customer Relationships; Customer Segments; Channels; Cost Structure and Revenue Streams)

UNIT-V:

Business Excellence Models: Core values and concepts – Business Excellence frameworks of USA (MBNQA); Europe (EFQM) and CII-EXIM Model of India.

Note * Bold : Content can be delivered online
--

TEXT BOOKS

1. Osterwalder, Alexander and Yves Pigneur; “Business Model Generation”, John Wiley & Sons, New Jersey, 2012.
2. Roy Rajeev, “Entrepreneurship” Oxford Latest Edition, 2008

REFERENCE

1. Arya Kumar, Entrepreneurship, 1st Edition, Pearson, Delhi, 2012.
2. Poornima M. Ch., Entrepreneurship Development- Small Business Enterprises, 1st Edition, Pearson, Delhi, 2009
3. Afuah, Allan; “Business Models: A Strategic Management Approach”, 1st Edition, McGraw-Hill, New York, 2004.
4. E. Gordon & K. Natarajan “Entrepreneurship Development” 6th Revised Edition, Himalaya Publishing house, 2008,
5. Coulter, Entrepreneurship in Action, 2nd Edition, PHI, 2002.

The Guidelines to be followed by the question paper setters in ENTREPRENEURSHIP DEVELOPMENT for the first semester-end exams

PAPER TITLE: ENTREPRENEURSHIP DEVELOPMENT

PAPER-4 Semester-1 Maximum Marks: 70 Duration: 3 Hours

Weightage for the question paper

Syllabus	Section –A (short answer questions) (with internal choice)	Section- B (Long answer questions) (with internal choice)	Section –C (essay question) (with internal choice)
Unit -1	1 (a or b)	1 (a or b)	Any unit
Unit -2	1 (a or b)	1 (a or b)	
Unit -3	1 (a or b)	1 (a or b)	
Unit -4	1 (a or b)	1 (a or b)	
Unit -5	1 (a or b)	1 (a or b)	

- Each short answer question carries 4 marks in section-A.
- Each long answer question carries 8 marks in section-B.
- Each essay answer question carries 10 marks in section-C.

The Question Paper Setters are requested to cover all the topics in the syllabus stipulated as per the weightage given by us.

MODEL QUESTION PAPER
M.COM. (REGULAR) DEGREE EXAMINATION
First Semester
ENTREPRENEURSHIP DEVELOPMENT
(2021-2022 Regulation Onwards)

Duration: 3 hours

Maximum Marks: 70

SECTION- A

1. Answer All Questions

5×4=20 Marks

- i. a) Distinguish Entrepreneurship Vs. Intrapreneurship. (CO1) (L4) or
b) Define an Entrepreneur (CO1) (L1)
- ii. a) Define the source of Ideas. (CO2) (L1) or
b) Business Development (CO2) (L1)
- iii. a) What do you mean by Working Capital Management ? (CO3) (L1) or
b) Project appraisal (CO3) (L1)
- iv. a) KVIC (CO4) (L1) or
b) CII (CO4) (L5)
- v. a) Meaning of SSIs(CO5) (L2) or
b) Explain Tax Holiday (CO5) (L2)

SECTION – B

Answer All Questions

5×8=40Marks

2. a) Explain the importance of entrepreneurship in economic development. (CO1) (L2)
(Or)
b) Elaborate the role of women entrepreneurship in India. (CO1) (L6)
3. a) What are the steps in assessing business potential of an idea? (CO2) (L1)
(Or)
b) Explain the importance of ideas in entrepreneurship. (CO2) (L2)
4. a) What is meant by Venture Capital? Explain the relevance of Venture Capital finance in Economic Development. (CO3) (L1, L2)
(Or)
b) Discover the role of institutional finance in entrepreneurship development. (CO3) (L1)
5. a) Examine the role of SFC in supporting small business enterprises in India.
(Or)
b) Evaluate the role of SFC in supporting small business enterprises in AP.(CO4) (L6)
6. a) Critically examine the policy of the Govt. towards SSIs. (CO5) (L5)
(Or)
b)What are the tax concessions available to SSIs in rural and backward areas?. (CO5) (L6)

SECTION C - (1 x 10=10 marks)

Answer the following question.

7. a) What are the guidelines observed for project report preparation? (CO5) (L6)
(Or)
b) Distinguish between management and entrepreneurship. (CO5) (L3)



A. G & S.G. SIDDHARTHA DEGREE COLLEGE OF ARTS & SCIENCE

Vuyyuru-521165.

NAAC reaccredited at 'A' level

Autonomous -ISO 9001 – 2015 Certified

TITLE OF THE PAPER: INFORMATION TECHNOLOGY FOR BUSINESS

Semester: I

Course Code	CO115	Course Delivery Method	Class Room / Blended Mode - Both
Credits	4	CIA Marks	30
No. of Lecture Hours / Week	5	Semester End Exam Marks	70
Total Number of Lecture Hours	75	Total Marks	100
Practical Component	01 Hour/Week	Exam Hours	03
Year of Introduction:	Year of Offering: 2021 - 22	Year of Revision: ----	Percentage of Revision: 0%
CLASS:	1 M.Com		

Course Outcomes:

- CO-1 To explain the role of Information Technology in Business
- CO-2 To illustrate the Information Technology Infrastructure
- CO-3 To describe Information Systems Support to for Business Functions
- CO-4 To represent Data, Knowledge and Implication of Decision Support Systems
- CO-5 To relating Strategic Advantage and Information Technology.

INFORMATION TECHNOLOGY FOR BUSINESS

Unit-I: Information Technology (IT) in Business Environment: Business in the Information Age - Pressures and Responses, **Why do we need to know about Information Technology**, What is an Information System, Capabilities of Information Systems - Basic concepts of Information Systems, organizations - Structures and **IT support - IT support at different organizational levels, Managing IT in organizations.**

Unit-II: IT Infrastructure: Computer Hardware - Input Technologies, Output Technologies - Computer Software - Types of software, general functions of Operating system, Types of application software - Managing organizational Data and Information - Basics of Data arrangement and Access, Traditional file Environment. Databases: Modern Approach, Database Management Systems - Logical Data Models, Data Warehouse. **Telecommunications systems and Networks - Network communications software, Internet: Services provided by Internet, World Wide Web, Intranets and Extranets.**

Unit-III: Information Systems to Support Business Functions: Transaction Processing Systems, Accounting and Finance Systems, Production Management Systems, Human Resources Management Systems, Integrated Information Systems and Enterprise Resource Planning, Inter-organizational/Global Information Systems. **Electronic Commerce - Types, Benefits of E-Commerce, Infrastructure and E-commerce support, Legal and ethical issues in E-commerce.** Computer-based Supply chain management and IS Integration: IT supply chain support and systems Integration: Enterprise Resource Planning.

Unit-IV: Data, Knowledge and Decision Support: Decision making and Decision support systems, Enterprise Decision support, Knowledge Management and Organizational Knowledge bases. Intelligent systems in Business: Expert systems, Intelligent Agents.

Unit-V: MS Office (Advanced): MS Word, Excel, and Power Point etc.

Reference Books:

1. V. Rajaraman- Introduction to Information Technology 2nd Edition (2013), PHI
2. Turban/Rainer/Potter- Introduction to Information Technology, 3rd Edition Willey.
3. Alexis Leon, Mathew Leon, Fundamentals of Information Technology, 2nd Edition (2015) LeonVikas.
4. [Turban/Volonino/Wood/O.P. Wali](#) - Information Technology for Management,(2015).

The Guidelines to be followed by the question paper setters in INFORMATION TECHNOLOGY FOR BUSINESS for the first semester-end exams

PAPER TITLE: INFORMATION TECHNOLOGY FOR BUSINESS

PAPER-5 Semester-1 Maximum Marks: 70 Duration: 3 Hours

Weightage for the question paper

syllabus	Section –A (short answer questions) (with internal choice)	Section- B (Long answer questions) (with internal choice)	Section –C (essay question) (with internal choice)
Unit -1	1 (a or b)	1 (a or b)	Any unit
Unit -2	1 (a or b)	1 (a or b)	
Unit -3	1 (a or b)	1 (a or b)	
Unit -4	1 (a or b)	1 (a or b)	
Unit -5	1 (a or b)	1 (a or b)	

- Each short answer question carries 4 marks in section-A.
- Each long answer question carries 8 marks in section-B.
- Each essay answer question carries 10 marks in section-C.

The Question Paper Setters are requested to cover all the topics in the syllabus stipulated as per the weightage given by us.

MODEL QUESTION PAPER
M.COM. (REGULAR) DEGREE EXAMINATION
First Semester
INFORMATION TECHNOLOGY FOR BUSINESS
(2021-2022 Regulation Onwards)

Duration: 3 hours

Maximum Marks: 70

SECTION- A

1. Answer All Questions

5×4=20 Marks

- i. a) What are the differences between Information Technology and Information Systems?(CO1)(L1) or
b) What are the capabilities of information system? (CO1)(L1)
- ii. a) What are the various input devices of the computers?(CO2)(L1) or
b)What are the differences between intranet and extranet(CO2)(L1)
- iii. a) Distinguish integrated information systems(CO3)(L4) or
b) What is a human resource management systems(CO3)(L1)
- iv. a) What are the differences between decision making and decision support systems(CO4)(L1) or
b) Explain knowledge management bases(CO4)(L2)
- v. a) Explain internet communities.(CO5)(L2) or
b) What do you mean by business process re-engineering? (CO5)(L1)

SECTION – B

Answer All Questions

5×8=40Marks

2. a)What is an Information system. Explain the capabilities of Information systems (CO1)(L1)

(OR)

b) Explain about Information Technology in organizations. (CO1)(L2)
3. a) What is an operating system. Explain the general functions of operating systems. (CO2)(L1)

(OR)

b) What are the differences between File based approach and Database Approach. (CO2)(L1)
4. a)Explain the types and benefits of E-commerce. (CO3)(L2)

(OR)

b) Explain briefly about computer based supply chain management. (CO3)(L2)
5. a) Explain briefly about the features, benefits and limitations of export systems. (CO4)(L2)

(OR)

b) Explain intelligent agents and how they are used in today business. (CO4)(L2)
6. a) Explain how Information Technology is implemented in organization and its impact on society. (CO5)(L2)

(OR)

b) What are the ethical issues involved in implementing Information Technology.
(CO5)(L1)

SECTION C - (1 x 10=10 marks)

Answer the following question.

7. a) What is DBMS. Explain the architecture and benefits of this system(CO2)(L1)
(OR)
b) Explain the societal impacts of Information Technology and different ways of protecting Information Systems(CO5)(L2)



A. G & S.G. SIDDHARTHA DEGREE COLLEGE OF ARTS & SCIENCE

Vuyyuru-521165.

NAAC reaccredited at 'A' level

Autonomous -ISO 9001 – 2015 Certified

TITLE OF THE PAPER: QUANTITATIVE TECHNIQUES FOR BUSINESS DECISIONS

Semester: I

Course Code	CO116	Course Delivery Method	Class Room / Blended Mode - Both
Credits	4	CIA Marks	30
No. of Lecture Hours / Week	5	Semester End Exam Marks	70
Total Number of Lecture Hours	75	Total Marks	100
Practical Component	01 Hour/Week	Exam Hours	03
Year of Introduction:	Year of Offering: 2021 - 22	Year of Revision: ----	Percentage of Revision: 0%
CLASS:	1 M.Com		

Course Outcomes:

- CO-1 To provide students with knowledge of mathematical models for quantitative analysis of managerial problems in Industry.
- CO-2 To develop the ability to evaluate the forecasting models like correlation and regression analysis.
- CO-3 To enable the students understanding probability concepts and its applications in business.
- CO-4 To evaluate the probability distributions and its applications in industry.
- CO-5 To understand the significance of testing of hypothesis in managerial decision-making.

QUANTITATIVE TECHNIQUES FOR BUSINESS DECISIONS

UNIT-I: Matrices, Differentiation, Permutations and combinations: Matrices –Basic concepts ,Solving system of equations with Cramer’s rule and Inverse method - Differentiation and integration of simple functions and their applications- Permutations and Combinations.

UNIT-II: Correlation and Regression: Correlation: Types of Correlation - Simple and Rank Correlation coefficient in the case of two variables- **Regression: Meaning and importance of Regression Analysis.** Estimation of Lines of Regression in the case of two variables.

UNIT-III: Probability: Concept of Probability: Definitions of Probability, Addition Theorem of Probability, Conditional Probability and Multiplication theorems of Probability, Baye’s Theorem of Probability and its **Applications.**

UNIT- IV: Theoretical distributions: Binomial Distribution, Poisson distribution and Normal distribution – their **Properties and Applications.**

UNIT-V: Testing of Hypothesis: Concept of Testing of Hypothesis, Types of Errors, Standard deviations and Proportions, Z- test for Means, T-test, F-test for two variances and Chi-Square test for goodness of fit and independent of Attributes and their Applications – Confidence intervals.

NOTE: *BOLD CONTENT CAN BE DELIVERED ONLINE

Suggested Books:

1. S.C. Gupta.-, Fundamentals of Statistics, 7th Revised Edition (2013) Himalaya Publishing House, New Delhi..
2. Sharma, J.K.-, Fundamentals of Business Statistics, 2nd Edition (2000) Pearson Education, New Delhi..
3. Sancheti, Dc & V.K Kapoor, Business Mathematics, 3rd Edition (2014) Sultan Chand & Sons, New Delhi..
4. Arora, P. N., S. Arora- Comprehensive Statistical Methods, 2nd Edition (2007) S. Chand, New Delhi.
5. Sharma, J.K., Quantitative Methods- Theory & Applications, 3rd Edition (2010) Macmillan New Delhi

The Guidelines to be followed by the question paper setters in QUANTITATIVE TECHNIQUES FOR BUSINESS for the first semester-end exams

PAPER TITLE: QUANTITATIVE TECHNIQUES FOR BUSINESS

PAPER-6 Semester-1 Maximum Marks: 70 Duration: 3 Hours

Weightage for the question paper

syllabus	Section –A (short answer questions) (with internal choice)	Section- B (Long answer questions) (with internal choice)	Section –C (essay question) (with internal choice)
Unit -1	1 (a or b)	1 (a or b)	Any unit
Unit -2	1 (a or b)	1 (a or b)	
Unit -3	1 (a or b)	1 (a or b)	
Unit -4	1 (a or b)	1 (a or b)	
Unit -5	1 (a or b)	1 (a or b)	

- Each short answer question carries 4 marks in section-A.
- Each long answer question carries 8 marks in section-B.
- Each essay answer question carries 10 marks in section-C.

The Question Paper Setters are requested to cover all the topics in the syllabus stipulated as per the weightage given by us.

MODEL QUESTION PAPER
M.COM. (REGULAR) DEGREE EXAMINATION
First Semester
QUANTITATIVE TECHNIQUES FOR BUSINESS DECISIONS
(2021-2022 Regulation Onwards)

Duration: 3 hours

Maximum Marks: 70

SECTION- A

1. Answer All Questions

5×4=20 Marks

- i. a) Explain permutations and combinations. (CO1)(L2) or
b) Distinguish Differentiation from Integration (CO1) (L4)
- ii. a) What is correlation and explain different types of correlation?(CO2) (L2) or
b) What are the properties of regression coefficients? (CO2)(L1)
- iii. a) State Addition Theorem of Probability(CO3)(L2) or
b) Define i) Exhaustive events ii) Equally likely events(CO3)(L1)
- iv. a) What is the importance of Poisson distribution?(CO4)(L2) or
b) What are the properties of Binomial Distribution (CO4)(L2)
- v. a) Distinguish between Type-I and Type-II errors(CO5)(L4) or
b) Explain the procedure for testing of hypothesis (CO5)(L2)

SECTION – B

Answer All Questions

5×8=40Marks

2.a) Solve the following Simultaneous Linear Equations by using Cramer's Rule (CO1)(L3)

$$2x+y-Z=3; x+y+z =1; x-2y-3Z=4$$

OR

b)A company has examined its cost structure and revenue structure and has determined that C the total cost, R total revenue, and x the number of units produced are related as: (CO1)(L3)

$$C=100+0.015 x^2 \text{ and } R=3x$$

Find the production rate x that will maximize profits of the company. Find that profit. Find also the profit when x=120.

3. a) Find the Karl Pearson's Coefficient of Correlation from the following data: (CO2)(L1)

Marks in Economics	45	55	56	58	60	65	68	70	75	80	85
Marks in Statistics	56	50	48	60	62	64	65	70	74	82	90

OR

b) The following data about the sale and advertisement expenditure of a firm is given below. (CO2)(L3)

	Sales(in Crores of Rupees)	Advertisement Expenditure(in Crores of Rs)
Means	40	6
Standard Deviation	10	1.5

Coefficient of Correlation $=r= 0.9$

- I. Estimate the likely sales for a proposed advertisement expenditure of Rs. 10 Crores.
- II. What should be the advertisement expenditure if the firm proposes a sales target of 60 Crores of Rupees?

4.a)i) A box contains 6 red, 4 white and 5 blue balls. From this box 3 balls are drawn in succession. Find the probability that they are drawn in the order red, white and blue if each balls is i) replaced ii) not replaced(CO3)(L1)

OR

b) The contents of urns I, II and III are as follows: (CO3)(L3)

1 white, 2 black and 3 red balls,

2 white, 1 black and 1 red balls, and

4 white, 5 black and 3 red balls

One urn is chosen at random and two balls drawn. They happen to be white and red. What is the probability that they came from urns I, II or III?

5.a) What is Normal Distribution? Explain characteristics and importance of the normal distribution. (CO4)(L2)

OR

b) If 5% of the electric bulbs manufactured by a company are defective, use Poisson distribution to find the probability that in a sample of 100 bulbs (i) none is defective, (ii) 5 bulbs will be defective.(Given $e^{-5}=0.007$) (CO4)(L3)

6. a) In a sample of 400 parts manufactured by a factory, the number of defective parts was found to be 30. The company, however, claimed that only 5% of their product is defective. Is the claim tenable? (CO5)(L3)

OR

b) Two types of batteries are tested for their length of life and the following data are obtained: (CO5)(L3)

	No. of Samples	Mean life in Hours	Variance
Type A:	9	600	121
Type B:	8	640	144

Is there a significance difference in the two means? (Table value=2.131)

SECTION C - (1 x 10=10 marks)

Answer the following question.

a) From the following data, use χ^2 -test and conclude whether inoculation is effective in preventing tuberculosis: (CO5)(L4)

	Attacked	Not attacked	Total
Inoculated	31	469	500
Not inoculated	185	1,315	1,500
Total	216	1,784	2,000

OR

b) In order to make a survey of the buying habits, two markets A and B are chosen at two different parts of a city. 400 women shoppers are chosen at random in market A. Their average weekly expenditure on food is found to be Rs.250 with a standard deviation of Rs.40. The figures are Rs.220 and Rs.55 respectively in the market B where also 400 women shoppers are chosen at random. Test at 1% level of significance whether the average weekly food expenditures of the two populations of shoppers are equal. (CO5)(L4)



A. G & S.G. SIDDHARTHA DEGREE COLLEGE OF ARTS & SCIENCE

Vuyyuru-521165.

NAAC reaccredited at 'A' level

Autonomous -ISO 9001 – 2015 Certified

TITLE OF THE PAPER: BUSINESS COMMUNICATION SKILLS

Semester: III

Course Code	CO311	Course Delivery Method	Class Room / Blended Mode - Both
Credits	4	CIA Marks	30
No. of Lecture Hours / Week	5	Semester End Exam Marks	70
Total Number of Lecture Hours	75	Total Marks	100
Practical Component	01 Hour/Week	Exam Hours	03
Year of Introduction:	Year of Offering: 2021 - 22	Year of Revision: ----	Percentage of Revision: 0%
CLASS:	II M.Com		

Course Outcomes:

- CO-1 To explain the importance of business correspondence and differentiate between formal and informal communication.
- CO-2 To impart knowledge in completing forms and learning and understanding the different accents and dialects.
- CO-3 To prepare and deliver effective business presentation with modern days technology.
- CO-4 To develop the art of business reporting system with good vocabulary and with lucid numerical presentations.
- CO-5 To explain the importance of feedback mechanism motivating others and building team management skills.

BUSINESS COMMUNICATION SKILLS

UNIT – I

Business Correspondence – Significance – Formal, informal and semiformal correspondence – **Written Correspondence** – Differences between formal and informal writings – Use of formal vocabulary and functional language in business letter writing–e-mail writing skills, **call taking etiquette/skills**.

UNIT – II

Business Information– Polite phrases of confirmation and communication breakdown – understanding native speaking accents and dialects – **Functional language used in making verbal agreements**.

UNIT – III:

Business Presentations– Use of information in presenting product features –Giving and Interpreting numerical data, **Business abbreviations, and acronyms** – **7C's of Communication**.

UNIT – IV:

Business Reporting– Effective presentation of oral and written instructions – Presenting and describing company information: **Summarizing important information concisely** – **Report Writing**.

UNIT – V:

Feedback and Evaluation– Giving feedback to others – Use of questions in self – Assessment elicitation – Agreement/disagreement and opinion giving – Feedback – **Strategies for effective relationship** – **Team building skills**.

NOTE: *BOLD CONTENT CAN BE DELIVERED ONLINE

References :

1. Barry, R. E., & Ellison, P. T. (1997). *Business Communication for 21st Century* (3rd ed.) Prentice Hall.
2. Bhatia, R. C. (2006). *Business Communication*. New Delhi, India: Ane Books .
3. Guffey, M. E., & Seefer, C. M. (2016). *Business English* (12th ed.). Massachusetts, US: Cengage Learning.
4. Henderson, G. L., & Voiles, P. R. (1986). *Business English Essentials* (7th ed.). New York, US: Gregg Division McGraw-Hill.
5. Stewart, Marie M, Hutchinson, Lois, & Zimmer, Kenneth . (1961). *Business English & Communication*. New York, US: McGraw-Hill .

The Guidelines to be followed by the question paper setters in BUSINESS COMMUNICATION SKILLS for the first semester-end exams

PAPER TITLE: BUSINESS COMMUNICATION SKILLS

PAPER-1 Semester-3 Maximum Marks: 70 Duration: 3 Hours

Weightage for the question paper

syllabus	Section –A (short answer questions) (with internal choice)	Section- B (Long answer questions) (with internal choice)	Section –C (essay question) (with internal choice)
Unit -1	1 (a or b)	1 (a or b)	Any unit
Unit -2	1 (a or b)	1 (a or b)	
Unit -3	1 (a or b)	1 (a or b)	
Unit -4	1 (a or b)	1 (a or b)	
Unit -5	1 (a or b)	1 (a or b)	

- Each short answer question carries 4 marks in section-A.
- Each long answer question carries 8 marks in section-B.
- Each essay answer question carries 10 marks in section-C.

The Question Paper Setters are requested to cover all the topics in the syllabus stipulated as per the weightage given by us.

MODEL QUESTION PAPER
M.COM. (REGULAR) DEGREE EXAMINATION
Third Semester
CO311 – BUSINESS COMMUNICATION SKILLS
(2021-2022 Regulation Onwards)

Duration: 3 hours

Maximum Marks: 70

SECTION- A

Answer Any Five of the Following Questions

5×4=20 Marks

1. **Write Short Notes on:**
- a. Vocabulary.(CO-1)(L1)
 - b. Writing Skills. (CO-1)(L2)
 - c. Communication Break Down(CO-2)(L3)
 - d. Accents. (CO-2)(L2)
 - e. Dialects. (CO-2)(L2)
 - f. Verbal Agreements. (CO-2)(L2)
 - g. Report Writing. (CO-4)(L2)
 - h. Feedback. (CO-5)(L4)

SECTION – B

Answer All Questions

5×8=40 Marks

2. a) Discuss the importance of communication in business. (CO-1)(L2)
OR
b) Explain the importance of functional language in business letter writing. (CO-1)(L2)
3. a) Discuss the importance of gathering business information. (CO-2)(L2)
OR
b) Discuss the importance of native speaking accents. (CO-2)(L2)
4. a) Explain 7Cs of communication. (CO-3)(L2)
OR
b) Discuss different business presentation techniques. (CO-3)(L3)
5. a) Discuss effective business reporting methods. (CO-4)(L3)
OR
b) Explain the importance of conciseness while preparing business reports. (CO-4)(L3)
6. a) Discuss the feedback and evaluation process in communication. (CO-5)(L4)
OR

- b) Explain the role of communication in team building. (CO-5)(L2)

SECTION C - (1 x 10=10 marks)

Answer the following question.

7. a) Explain the role of technology in communication. (CO-1)(L2)
OR
b) Discuss the importance of negotiation techniques in agreement and disagreement.
(CO-1)(L2)



A. G & S.G. SIDDHARTHA DEGREE COLLEGE OF ARTS & SCIENCE

Vuyyuru-521165.

NAAC reaccredited at 'A' level

Autonomous -ISO 9001 – 2015 Certified

TITLE OF THE PAPER: FINANCIAL INSTITUTIONS & MARKETS

Semester: III

Course Code	CO312	Course Delivery Method	Class Room / Blended Mode - Both
Credits	4	CIA Marks	30
No. of Lecture Hours / Week	5	Semester End Exam Marks	70
Total Number of Lecture Hours	75	Total Marks	100
Practical Component	01 Hour/Week	Exam Hours	03
Year of Introduction:	Year of Offering: 2021 - 22	Year of Revision: ----	Percentage of Revision: 0%
CLASS:	II M.Com		

Course Outcomes:

- CO-1 To examine the role of the financial system in the economy.
- CO-2 To familiarize the students with the financial institutions, markets and its regulations.
- CO-3 To help the students in acquiring analytical skills in the market analysis in the context of raising medium and long term funds.
- CO-4 To give the students an understanding of the behaviour of banks and other financial firms.
- CO-5 To make the students understand the role and functions of organized financial markets and financial Service Firms.

FINANCIAL INSTITUTIONS & MARKETS

UNIT-I

Structure of Indian Financial System – Role of Financial System in Economic Development – Financial Markets and Financial Instruments – Capital Markets – Money Markets – Primary Market Operations – Role of SEBI – Secondary Market Operations – Functions of Stock Exchange – Financial Services Sector Problems and Reforms.

UNIT-II

Financial Institutions – Banking & Non-banking Financial Institutions – New Financial Institutions– the Discount Finance House of India, Stock Holding Corporation of India Limited, Infrastructural Leasing and Financial Services Limited– Indian Banking System: An Overview, Role of Reserve Bank of India.

UNIT-III

Development Banks– Objectives and Scope of Development Banks – Industrial Finance Corporation of India(IFCI Ltd.), – National Bank for Agricultural and Rural Development(NABARD), National Housing Bank(NHB), Export and Import Bank of India(EXIM Bank of India), Small Industrial Development Bank of India(SIDBI).

UNIT-IV

International Financing Institutions: Objectives of International Financial Institutions – Source of Funds – The International Bank for Reconstruction and Development(IBRD), International Finance Corporation(IFC),International Development Association (IDA), Asian Development Bank(ADB) and International Monetary Fund(IMF).

UNIT-V

Financial Services – Concept, Nature and Scope of Financial Services – Merchant Banking – Meaning – Types – Responsibilities of Merchant Bankers in Issue Management – Credit Rating – Meaning, Functions – Mutual Funds – Concept ,Objectives and Functions.

Note: Bold Content can be Delivered online.

References:

- .Bhole LM, Financial Institutions and Market-Structure, Growth and Innovations, 6th,2018 . Tata McGraw Hill, Chennai.
- N K Gupta, Monika Chopra, Financial Markets and Services,2nd 2008,New Delhi.
- V A. Avadhani, Financial Services in India, 2nd 2010, Himalaya Publishers, Mumbai.
- Vasant Desai, Financial Markets and Financial, 4th 2013, Himalaya Publisher, Mumbai.

The Guidelines to be followed by the question paper setters in FINANCIAL INSTITUTIONS & MARKETS for the first semester-end exam

PAPER TITLE: FINANCIAL INSTITUTIONS & MARKETS

PAPER-2 Semester-3 Maximum Marks: 70 Duration: 3 Hours

Weightage for the question paper

syllabus	Section –A (short answer questions) (with internal choice)	Section- B (Long answer questions) (with internal choice)	Section –C (essay question) (with internal choice)
Unit -1	1 (a or b)	1 (a or b)	Any unit
Unit -2	1 (a or b)	1 (a or b)	
Unit -3	1 (a or b)	1 (a or b)	
Unit -4	1 (a or b)	1 (a or b)	
Unit -5	1 (a or b)	1 (a or b)	

- Each short answer question carries 4 marks in section-A.
- Each long answer question carries 8 marks in section-B.
- Each essay answer question carries 10 marks in section-C.

The Question Paper Setters are requested to cover all the topics in the syllabus stipulated as per the weightage given by us.

MODEL QUESTION PAPER
M.Com. (REGULAR) DEGREE EXAMINATION
Third Semester
CO312 – FINANCIAL INSTITUTIONS & MARKETS
(2021-2022 Regulation Onwards)

Time: Three hours

Maximum Marks: 70

SECTION – A

1. Answer any Five of the Following Questions (5X4 = 20 Marks)

- a) What do you understand by financial markets? (CO1)(L1)
- b) State the functions of The Discount Finance House of India. (CO2)(L2)
- c) Explain the importance of NABARD. (CO3)(L2)
- d) List out the objectives of International Monetary Fund.(CO4) (L2)
- e) Classify the Credit Rating Agencies.(CO5) (L1)
- f) Summarize Role of SEBI.(CO1)(L2)
- g) Examine the role of RBI. (CO2)(L3)
- h) Outline the major activities of Export and Import Bank. (CO3)(L1)

SECTION B

Answer All Questions: (5X8 = 40 Marks)

2. a) What is meant by Stock Exchanges? Explain the functions of Stock Exchanges.(CO1) (L2)
Or
b) Examine the Money Market Instruments. (CO1)(L4)
3. a) Analyze the Indian Banking System.(CO2)(L3)
Or
b) Explain the Role of Reserve Bank of India.(CO2)(L2)
4. a) Identify the Objectives and Scope of Development Banks of India(CO3) (L3)
Or
b) Justify the support of Small Industrial Development Bank of India in promotion of Small scale industries. (CO3)(L5)
5. a) Summarize the major activities of Asian Development Bank. (CO4)(L2)
Or
a) List out the objectives of International Financial Institutions.(CO4)(L3)
6. a) Explain the nature and scope of financial Services. (CO5)(L2)
Or
b) Explain the responsibilities of merchant bankers in issue management.(CO5)(L2)

SECTION –C 1X10 = 10 Marks

7. a) Analyse the Role of Financial System in Economic Development. (CO1)(L4)
Or

- b) Define Mutual Funds. Examine the concept, objectives and functions of mutual funds.
(CO5)(L4)



A. G & S.G. SIDDHARTHA DEGREE COLLEGE OF ARTS & SCIENCE

Vuyyuru-521165.

NAAC reaccredited at 'A' level

Autonomous -ISO 9001 – 2015 Certified

TITLE OF THE PAPER: ADVANCED COST ACCOUNTING

Semester: III

Course Code	CO321	Course Delivery Method	Class Room / Blended Mode - Both
Credits	4	CIA Marks	30
No. of Lecture Hours / Week	5	Semester End Exam Marks	70
Total Number of Lecture Hours	75	Total Marks	100
Practical Component	01 Hour/Week	Exam Hours	03
Year of Introduction:	Year of Offering: 2021 - 22	Year of Revision: ----	Percentage of Revision: 0%
CLASS:	II M.Com		

Course Outcomes:

- CO-1 To understand the basic concepts and processes used to determine product costs. And to interpret cost accounting statements.
- CO-2 To analyse and evaluate information for cost ascertainment in process, batch and job costing.
- CO-3 To analyse and evaluate the methodology for costing of operating and service industry.
- CO-4 To scrutinize various types of manufacturing waste and present a comprehensive cost system for recognizing and reporting waste costs.
- CO-5 To appraise the need for reconciliation between cost and financial accounts along with the preparation of a reconciliation statement. And explain the utility – concept and preparation of different types of budgets.

ADVANCED COST ACCOUNTING

UNIT – I

Overview of basic concepts in Accounting – Elements of Cost – Material – Labour and Overheads – Material Purchase procedure – **Storage and Inventory control** – **Methods of pricing of issues** – **Methods of inventory control** – **Labour** – Classification of Labour – Principles and Methods of Remuneration – Overheads – Meaning – classification – allocation – apportionment and absorption (Theory & Problems).

UNIT – II

Methods of Costing– Job Costing– Batch Costing – Unit Costing and Process Costing (Theory & Problems).

UNIT – III

Operating Costing – **Operating Costing** – **Costing and Service Industry** – **Hospital–Hotel** – **Transportation** – **Electricity** – **Power House and Telecommunication (Theory)**

UNIT – IV

Treatment of certain items – **General Principles of Treatment of Depreciation** – Amortization – interest on capital – Cost of Finance – Research and Development Cost – Material Losses – Waste – Scrap – Spoilage – Defectives (Theory).

UNIT – V

Cost Book Keeping and Reconciliation between Cost and Financial Accounts – Cost Book-Keeping – Cost Ledgers – Interlocking and Integral Accounts – **Reconciliation of Cost and Financial Accounts** – **Reasons** – **Need**. Cost Audit: Meaning – Advantages – Propriety Audit and efficiency Audit – Cost Audit Program. (Theory & Problems)

NOTE: * BOLD CONTENT CAN BE DELIVERED ONLINE

References:

1. M.Y Khan and P.K. Jain - Cost Accounting, 2nd edition, 2000, Tata McGraw Hill – New Delhi
2. A Murthy and S Gurusamy - Cost Accounting, 2nd edition, 2012, Tata McGraw Hill – New Delhi.
3. M.N. Arora – Accounting for Management, 3rd edition, 2010 – Himalaya Publishing House - New Delhi.
4. Periaswamy – Financial Cost & Management Accounting, 3rd edition, 2011 – Himalaya Publishing House - New Delhi.
5. Mitra J.K. Advanced Cost Accounting, 3rd edition, 2009 New Age International Pvt. Ltd. New delhi.

The Guidelines to be followed by the question paper setters in **ADVANCED COST ACCOUNTING** for the first semester-end exams

PAPER TITLE: ADVANCED COST ACCOUNTING

PAPER-3 Semester-3 Maximum Marks: 70 Duration: 3 Hours

Weightage for the question paper

syllabus	Section –A (short answer questions) (with internal choice)	Section- B (Long answer questions) (with internal choice)	Section –C (essay question) (with internal choice)
Unit -1	1 (a or b)	1 (a or b)	Any unit
Unit -2	1 (a or b)	1 (a or b)	
Unit -3	1 (a or b)	1 (a or b)	
Unit -4	1 (a or b)	1 (a or b)	
Unit -5	1 (a or b)	1 (a or b)	

- Each short answer question carries 4 marks in section-A.
- Each long answer question carries 8 marks in section-B.
- Each essay answer question carries 10 marks in section-C.

The Question Paper Setters are requested to cover all the topics in the syllabus stipulated as per the weightage given by us.

MODEL QUESTION PAPER
M.COM. (REGULAR) DEGREE EXAMINATION

Third Semester

CO321 – ADVANCED COST ACCOUNTING

(2021-2022 Regulation Onwards)

Duration: 3 hours

Maximum Marks: 70

SECTION- A

1. Answer Any Five of the Following Questions

5×4=20 Marks

- a. Elements of cost. (CO1) (L2)
- b. By product. (CO1) (L2)
- c. Abnormal loss. (CO2) (L2)
- d. Fixed Vs. Variable cost. (CO5) (L2)
- e. Job Costing. (CO2) (L2)
- f. Amortization. (CO4) (L2)
- g. Cost sheet (CO5) (L2)
- h. Memorandum reconciliation account. (CO5) (L2)

SECTION – B

Answer All Questions
Marks

5×8=40

2. a) Define cost accounting and explain its objectives. (CO 1)(L1)

OR

- b) In an engineering factory, the following particulars have been extracted for the year ended 31.12.2016.

	Production depts.			Service depts.	
	A	B	C	X	Y
Direct wages	30,000	45,000	60,000	15,000	30,000
Direct materials	15,000	30,000	30,000	24,500	22,500
Staff number	1,500	2,250	2,250	750	750
Electricity(kwh)	6,000	4,500	3,000	1,500	1,500
Asset value(Rs.)	60,000	40,000	30,000	10,000	10,000
Light points	10	16	4	6	4
Area(square meters)	150	250	50	50	50

The expenses for the period were as follows:

	Rs.
Power	1,100
Lighting	200
Stores overhead	800

Rent and taxes	550
Depreciation	30,000
Repairs	6,000
General overheads	12,000

Absorption the expenses of service dept. Y according to direct wages and those service dept. X in the ratio of 5:3:2 to the production depts.

You are required to prepare an overhead distribution summary.(CO1)(L 2)

3. a) Define costing techniques. Describe various techniques of costing.(CO2)(L1)

OR

- b) What is job costing? Explain the features of job costing.(CO2)(L1)(L2)

4. a) What is operating costing and explain different situations where operating costing be implemented?(CO3)(L1)(L2)

OR

- b) From the following data relating to a vehicle compute the cost per running km/hour.

	Rs.
Kilometers run (annual)	30,000
Km/hour (average)	12
Road license (average)	3,600
Cost of vehicle	5,00,000
Insurance(annual)	5,000
Salaries	3,400
Cost of fuel per hour	70
Repairs and maintenance/Km	4

Estimated life of the vehicle 2,00,000 Kms. Charge interest at 10% p.a. on the cost of vehicle. The vehicle runs 12 km per hour on an average.(CO3)(L3)

5. a) Explain how depreciation and research and development cost treated in cost accounting records.(CO4)(L 2)

OR

- b) State important ways of classification of costs and discuss each of them in detail.(CO4)(L2)(L6)

6. a) Why is reconciliation of cost and financial necessary? State the possible reasons for the difference.(CO5)(L 1)

OR

- b) Define cost audit. Explain about the cost audit programme and its advantage.(CO5)(L1)(L2)

SECTION C - (1 x 10=10 marks)

Answer the following question.

7. a) Explain the causes for disagreement in profits between cost and financial accounts.(CO5)(L2)

OR

- b) The following data relate to a manufacturing firm for 4 weeks ending on 31st Mar 2016.(CO5)(L 1)

Raw materials consumed	Rs.20,000/-
Direct wages	Rs.12,000/-
Machine hours worked	1000 hrs
Machine hour rate	Rs.2/- per hour
Office overheads	20% on works cost
Selling overheads	Rs.0.40/- per unit
Units produced	20,000 units
Units sold at Rs. 3 each	18,000 units

Prepare a cost sheet to show

- (i) Prime cost
- (ii) Works cost
- (iii) Cost of production
- (iv) Cost of goods sold and profit



A. G & S.G. SIDDHARTHA DEGREE COLLEGE OF ARTS & SCIENCE

Vuyyuru-521165.

NAAC reaccredited at 'A' level

Autonomous -ISO 9001 – 2015 Certified

TITLE OF THE PAPER: CORPORATE ACCOUNTING

Semester: III

Course Code	CO322	Course Delivery Method	Class Room / Blended Mode - Both
Credits	4	CIA Marks	30
No. of Lecture Hours / Week	5	Semester End Exam Marks	70
Total Number of Lecture Hours	75	Total Marks	100
Practical Component	01 Hour/Week	Exam Hours	03
Year of Introduction:	Year of Offering: 2021 - 22	Year of Revision: ----	Percentage of Revision: 0%
CLASS:	II M.Com		

Course Outcomes:

- CO-1 To understand financial statements (comprising statement of comprehensive income, balance sheet, statement of cash flow, statement of changes in equity and notes to accounts) from a user perspective such as an equity investor, lender, financial analyst and management.
- CO-2 To analyse the user perspective on the role of International financial reporting system.
- CO-3 To describe the importance of valuation of shares and elaborate the methods of valuation of shares.
- CO-4 To prepare the consolidated statement of financial statement and the consolidated statement of profit or loss.
- CO-5 To know the concepts of new trends in inflation accounting and human resource accounting.

CORPORATE ACCOUNTING

UNIT – I

Corporate Financial Accounting– Objectives-Scope – **Analysis and Interpretation of Financial Statements** – Common Size Balance Sheet – Comparative Balance Sheet.

UNIT – II

IFRS – Introduction – Meaning – scope – An overview of the IFRS, Role of IASB – Arguments for Global Convergence – Required disclosure as per IFRS - Achievements of IASB and obstacles in convergence – Difference between IFRS and IAS.

UNIT – III

Valuation of Shares – Need for Valuation of Shares – Factors Effecting Value of Shares – Methods of Valuation – Impact of Earnings on Share Valuation – Fair Value of a Share – Buy Back of Equity Shares.

UNIT – IV

Consolidated Financial Statements – Definition of Parent or Holding and its Subsidiary – Need for Consolidated Financial Statement – Preparation of Consolidated Balance Sheet of a Holding Company with one Subsidiary – Consolidation of Profit of Loss Account – Consolidated Statement of Changes in Financial Position.

UNIT-V

Human Resource Accounting– **Objectives – Methods of Valuation – Advantages and disadvantages** – Accounting for price level changes – CPP – CCA.

NOTE: * BOLD CONTENT CAN BE DELIVERED ONLINE

References :

1. Ashok Sehgal & Deepak Sehgal, Advanced Accounting – Corporate Accounting Vol. 2 2008, Taxmann Allied Services Pvt Ltd, New Delhi.
2. R.L. Gupta & Radhaswami, Advanced Accounting – Volume – 2; 2015, S. Chand & Co. Delhi.
3. R. Narayana Swami, Financial Accounting – A Managerial Perspective — 5th edition 2014, Prentice Hall of India, New Delhi.
4. S.N. Maheswari & S.K. Maheswari Corporate Accounting –, 6th edition 2018, Vikas Publishing House, NewDelhi.
5. Dr. S. Anil Kumar Dr. V. Rajesh Kumar Dr. B. Mariyappa, Advanced Corporate Accounting, 1st edition 2015, Himalaya Publishing House, NewDelhi.

The Guidelines to be followed by the question paper setters in CORPORATE ACCOUNTING for the first semester-end exams

PAPER TITLE: CORPORATE ACCOUNTING

PAPER-4 Semester-3 Maximum Marks: 70 Duration: 3 Hours

Weightage for the question paper

syllabus	Section –A (short answer questions) (with internal choice)	Section- B (Long answer questions) (with internal choice)	Section –C (essay question) (with internal choice)
Unit -1	1 (a or b)	1 (a or b)	Any unit
Unit -2	1 (a or b)	1 (a or b)	
Unit -3	1 (a or b)	1 (a or b)	
Unit -4	1 (a or b)	1 (a or b)	
Unit -5	1 (a or b)	1 (a or b)	

- Each short answer question carries 4 marks in section-A.
- Each long answer question carries 8 marks in section-B.
- Each essay answer question carries 10 marks in section-C.

The Question Paper Setters are requested to cover all the topics in the syllabus stipulated as per the weightage given by us.

MODEL QUESTION PAPER
M.COM. (REGULAR) DEGREE EXAMINATION
Third Semester
CO322 – CORPORATE ACCOUNTING
(2021-2022 Regulation Onwards)

Duration: 3 hours

Maximum Marks: 70

SECTION- A

1. Answer Any Five of the Following Questions

5×4=20 Marks

- a. Define nature and Scope of corporate accounting (CO1) (L1)
- b. Define concept of Inflation Accounting(CO5) (L1)
- c. Meaning of IFRS(CO2) (L1)
- d. Comparative balance sheet(CO1) (L1)
- e. Define Holding Company(CO4) (L1)
- f. Human Resources accounting(CO5) (L1)
- g. Need for valuation of shares(CO3) (L1)
- h. Buy Back of equity shares(CO3) (L1)

SECTION – B

Answer All Questions

5×8=40 Marks

2. a) Discuss the objectives and Scope of Financial Statements. (CO1) (L6)
(or)

b) From the following particulars prepare company Income statement(CO1) (L1)

Particulars	2005 (Rs)	2006 (Rs)
Net sales	1000000	1200000
Cost of sales	550000	605000
Selling Exp	60000	80000
Interest paid	40000	50000
Income tax	50000	80000

3. a) What are the need for valuation of shares. (CO2) (L1)
(or)

b) What are the methods of valuation of shares? (CO2) (L1)

4. a) Discuss the objectives and role of IASB. (CO3) (L6)
(or)

b) What is IFRS? Write a note on IFRS in India. (CO3) (L1)

5. a) Define a need for consolidated financial statement(CO4) (L1)
(or)

b) H ltd. acquires all the shares of S ltd on 1-1-2015 from the Balance sheet gives below demonstrate consolidated balance sheet. (CO4) (L2)

Liabilities	H.Ltd Rs.	S.Ltd Rs.	Assets	H.LtdRs.	S.LtdRs.
ShareCapital:			Land & Building	400000	270000
Shares of Rs 10 each	800000	300000	Plant & Machinery	200000	100000
Creditors	350000	160000	Furniture & Fitting	50000	20000
Bills Payable	40000	20000	Investments of Shares of S Ltd	500000	--
Reserves 1.4.2014	210000	40000	Stock	150000	80000
Profit & Loss	50000	30000	Sundry Debtors	100000	60000
			Bank Balance	50000	20000
Total	1450000	550000		1450000	550000

6. a) Define Inflation Accounting. Briefly explain its merits and demerits. (CO5) (L1)
(or)

b) Discuss the importance and problems in Human Resource Accounting. (CO5) (L6)

SECTION C - (1 x 10=10 marks)

Answer the following question.

7. a) What is meant by financial statements analysis. Explain its usefulness to different parties(CO1) (L1)

(or)

b)On 31-03-2016 the balance sheet of limited company disclosed the following position.
(CO3) (L5)

Liabilities	Rs.	Assets	Rs.
Share Capital	400000	Fixed Assets	500000
Reserve fund	90000	Current Assets	200000
Profit & Loss Account	20000	Good Will	40000
5% Debentures	100000		
Current Liabilities	130000		
Total	740000		740000

On 31st March,2016 the fixed assets were independently valued at Rs. 350000 and the Good will at Rs. 50000. The net profit for the three years were Rs.51600, Rs.52000, Rs. 51650.Of which 20% was placed to Reserve this proportion being considered reasonable in the industry in which the company is engaged and where a fair investment return may be taken at 10%.

Evaluate the value of shares by

(1) Net assets method

(2) Yield method.



A. G & S.G. SIDDHARTHA DEGREE COLLEGE OF ARTS & SCIENCE

Vuyyuru-521165.

NAAC reaccredited at 'A' level

Autonomous -ISO 9001 – 2015 Certified

TITLE OF THE PAPER: SECURITY ANALYSIS AND PORTFOLIO MANAGEMENT
Semester: III

Course Code	CO331	Course Delivery Method	Class Room / Blended Mode - Both
Credits	4	CIA Marks	30
No. of Lecture Hours / Week	5	Semester End Exam Marks	70
Total Number of Lecture Hours	75	Total Marks	100
Practical Component	01 Hour/Week	Exam Hours	03
Year of Introduction:	Year of Offering: 2021 - 22	Year of Revision: ----	Percentage of Revision: 0%
CLASS:	II M.Com		

Course Outcomes:

After completion of the course, the student is able to

- CO-1 Understand the various forms of investment, security Markets and other concepts
- CO-2 Understand risks associated with investment
- CO-3 Measure risk and return of different security instruments and portfolio
- CO-4 Analyse the fundamental strength of stocks and predict the price trends of securities using technical analysis and valuation of stocks and fixed income securities
- CO-5 Evaluate the performance of portfolio.

SECURITY ANALYSIS AND PORTFOLIO MANAGEMENT

UNIT – I

Concept of Investment – Objectives – Investment Vs Speculation – Security Investment Vs Non-security Forms of Investment – Investment Process – Sources of Investment Information – Security Markets – Primary and Secondary – Market Indices.

UNIT – II

Return and Risk – Meaning and Measurement of Security Returns – Types of Security Risks – Systematic Vs Non-systematic Risk – Measurement of Total Risk.

UNIT – III

Fundamental Analysis of Stocks – Economy, Industry and Company Analysis, Intrinsic Value – Approach to Valuation of Bonds, Preference Shares and Equity Shares.

UNIT – IV

Technical Analysis– Concept and Tools of Technical Analysis – Technical Analysis Vs Fundamental Analysis – Efficient Market Hypothesis – Concept and Forms of Market Efficiency.

UNIT – V

Elements of Portfolio Management – Portfolio Models – Markowitz Model, Efficient Frontier, Sharpe Single Index Model and Capital Asset Pricing Model – Performance Evaluation of Portfolios – Sharpe Model, Treynor model – Jensen’s Model for PF Evaluation – Portfolio Revision.

Note:

Unit 3& 4 will be taught through online classes

References :

1. Fisher and Jordan, Security Analysis & Portfolio Management 6e, (2011) Pearson, PHI.
2. S. Kevin, Security Analysis & Portfolio Management, 2e (2015) Prentice Hall India.
3. Avadhani VA, Securities Analysis & Portfolio Management, 9e (2017) Himalaya Publishing House.
4. Prasanna Chandra, Investment Analysis and Portfolio Management 3e, (2011) Tata McGraw-Hill Education
5. P. Pandian, Security Analysis and Portfolio Management, 1e (2014), Vikas Publishing House Pvt Limited.
6. Bhalla, VK, Investment Management, 19e (2017), S Chand.
7. Preeti Singh, Investment Management, 9e (2000), Himalaya Publishers.

The Guidelines to be followed by the question paper setters in SECURITY ANALYSIS AND PORTFOLIO MANAGEMENT for the first semester-end exams

PAPER TITLE: SECURITY ANALYSIS AND PORTFOLIO MANAGEMENT

PAPER-5 Semester-3 Maximum Marks: 70 Duration: 3 Hours

Weightage for the question paper

syllabus	Section –A (short answer questions) (with internal choice)	Section- B (Long answer questions) (with internal choice)	Section –C (essay question) (with internal choice)
Unit -1	1 (a or b)	1 (a or b)	Any unit
Unit -2	1 (a or b)	1 (a or b)	
Unit -3	1 (a or b)	1 (a or b)	
Unit -4	1 (a or b)	1 (a or b)	
Unit -5	1 (a or b)	1 (a or b)	

- Each short answer question carries 4 marks in section-A.
- Each long answer question carries 8 marks in section-B.
- Each essay answer question carries 10 marks in section-C.

The Question Paper Setters are requested to cover all the topics in the syllabus stipulated as per the weightage given by us.

MODEL QUESTION PAPER

M.COM. (REGULAR) DEGREE EXAMINATION

Third Semester

CO331 – SECURITY ANALYSIS & PORTFOLIO MANAGEMENT

(2021-2022 Regulation Onwards)

Duration: 3 hours

Maximum Marks: 70

SECTION- A

1. Answer Any Five of the Following Questions

5×4=20 Marks

- a. Speculation (CO1) (L2)
- b. Market indices (CO1,CO3) (L2)
- c. Systematic Risk (CO2) (L2)
- d. Market breadth (CO1) (L2)
- e. Industry life cycle (CO1) (L2)
- f. DOW Theory (CO4) (L2)
- g. Efficient frontier (CO1) (L2)
- h. Jensen measure (CO1) (L2)

SECTION – B

Answer All Questions

5×8=40 Marks

2. a. Explain different investment avenues and their characteristics. (CO1) (L2)
(OR)
b. Explain the Investment Process. (CO1) (L2)
3. a. Explain different types of Systematic Risks associated with Investment. (CO2) (L2)
(OR)
b. Calculate the expected return and the standard deviation of returns for a stock having the following probability distribution of returns. (CO3) (L4)

Possible returns (in per cent)	Probability of occurrence
-25	0.05
-10	0.05
0	0.15
15	0.25
20	0.30
30	0.15
35	0.05

4. a. Explain the fundamental analysis of stocks. (CO4) (L2)

(OR)

b. Explain different models of calculating intrinsic value of stock. (CO4) (L4)

5. a. Discuss different Tools used in Technical Analysis. (CO3) (L4)

(or)

b. What is Random Walk Theory? Explain different forms of EMH. (CO1) (L2)

6. a. Explain Capital Asset Pricing Model and assumptions. (CO3) (L2)

(OR)

b. Given below are the historical performance of different mutual funds. The market return is 12% having a standard deviation of 9% and risk free return is 7%. (CO5) (L5)

Year	Mutual fund return (percent)	Mutual fund beta	Standard deviation
1	13.85	1.25	10.00
2	28.00	1.20	21.00
3	35.00	1.18	11.05
4	11.25	1.20	7.50
5	20.0	1.02	12.00

Calculate the following risk adjusted return measures for the mutual fund and rank them using:

a) Sharpe ratio

b) Treynor ratio

c) Jensen differential return

SECTION C - (1 x 10=10 marks)

Answer the following question.

7. A) Explain Markowitz Model of Portfolio Construction. (CO3) (L2)
(OR)

B) The share of ABC Company is currently selling for Rs.65 per share, dividend per share has grown from Rs.2 to the current level of Rs.5 over the past 10 years, and this dividend growth is expected to continue in the future. Calculate the rate of return, if we purchase at this price. (CO5) (L5)



A. G & S.G. SIDDHARTHA DEGREE COLLEGE OF ARTS & SCIENCE

Vuyyuru-521165.

NAAC reaccredited at 'A' level

Autonomous -ISO 9001 – 2015 Certified

TITLE OF THE PAPER: BANK MANAGEMENT

Semester: III

Course Code	CO332	Course Delivery Method	Class Room / Blended Mode - Both
Credits	4	CIA Marks	30
No. of Lecture Hours / Week	5	Semester End Exam Marks	70
Total Number of Lecture Hours	75	Total Marks	100
Practical Component	01 Hour/Week	Exam Hours	03
Year of Introduction:	Year of Offering: 2021 - 22	Year of Revision: ----	Percentage of Revision: 0%
CLASS:	II M.Com		

Course Outcomes:

- CO-1 To familiarize the students with various laws related to banking.
- CO-2 To offer in-depth knowledge on banking systems and organizational structure of commercial banks in India.
- CO-3 To equip the students with the concepts of balance sheet management, profitability, and productivity in banks and management information system.
- CO-4 To understand the concepts of manpower planning, bank marketing and computerization of banks.
- CO-5 To provide conceptual understanding about e-banking, security methods and risk management.

BANK MANAGEMENT

UNIT – I

Nature of Banking Business – Banking Regulation Act, 1949 – Reserve Bank of India Act, 1934– Banking Companies Act, 1970.

UNIT – II

Forms of Banking – Branch Banking – Unit Banking – Group Banking – Chain Banking – Business, Correspondent Banking – Process of Bank Management – Organizational Structure of Commercial Banks in India.

UNIT – III

Bank Balance Sheet – Management of Assets and Liabilities in banks – Profit, Profitability and Productivity in banks – **Management of large sized branches and rural branches – Internal control and Performance budgeting system.**

UNIT – IV

Human Resource Development in Banks – Manpower Planning – Recruitment – Training – Promotion – Motivation – Bank Marketing – Product Planning and Development – **Computerization of Banks – Need – Application – Progress – Problems.**

UNIT – V

E-Banking – Aspects of E-Banking – Traditional Vs. E-Banking Models – Advantages and Constraints – Security Methods – Risk Management – **Outsourcing E-Banking – Legal and Regulatory Compliance.**

Note : * Bold Content can be delivered online
--

References :

1. Hawtrey, The art of Central Banking, 1st Edition, Sugustus M Kelley Publishers, 1970, New York.
2. Narendra Kumar, Bank Nationalism of India – A Symposium, 1st Edition, Lalvani Publishing House, 1969, Mumbai.
3. Koch, Bank Management , 8th Edition, South-Western College, 2015.
4. Vasant Desai, Indian Banking – Nature and Problems, 4th Revised Edition, Himalaya Publishing House, Mumbai, 1979.
5. Neelam C. Gulati , Principles of Banking Management, 9th Edition, Excel Books, 2010.

The Guidelines to be followed by the question paper setters in BANK MANAGEMENT for the first semester-end exams

PAPER TITLE: BANK MANAGEMENT

PAPER-6 Semester-3 Maximum Marks: 70 Duration: 3 Hours

Weightage for the question paper

syllabus	Section –A (short answer questions) (with internal choice)	Section- B (Long answer questions) (with internal choice)	Section –C (essay question) (with internal choice)
Unit -1	1 (a or b)	1 (a or b)	Any unit
Unit -2	1 (a or b)	1 (a or b)	
Unit -3	1 (a or b)	1 (a or b)	
Unit -4	1 (a or b)	1 (a or b)	
Unit -5	1 (a or b)	1 (a or b)	

- Each short answer question carries 4 marks in section-A.
- Each long answer question carries 8 marks in section-B.
- Each essay answer question carries 10 marks in section-C.

The Question Paper Setters are requested to cover all the topics in the syllabus stipulated as per the weightage given by us.

MODEL QUESTION PAPER
M.COM. (REGULAR) DEGREE EXAMINATION
Third Semester
CO332: BANK MANAGEMENT
(2021-2022 Regulation Onwards)

Duration: 3 hours

Maximum Marks: 70 marks

SECTION - A

- 1. Answer Any Five of the Following Questions** **5 x 4 = 20 Marks**
- a) Define Commercial Banks. (CO1) (L1)
 - b) Explain Unit Banking. (CO2) (L2)
 - c) What is Manpower Planning? (CO3) (L1)
 - d) Determine Bank Marketing. (CO3) (L5)
 - e) Define E- Banking. (CO5) (L1)
 - f) What do you mean by Overdraft ? (CO2) (L1)
 - g) Outline Foreign Banks. (CO5) (L2)
 - h) Interpret Risk Management. (CO5) (L2)

SECTION - B

Answer All Questions. **5 x 8 = 40 Marks**

2. a) Discover the constitution and main functions of Reserve Bank of India. (CO1) (L4)
(Or)
b) Examine the organization structure of Commercial Banks in India. (CO1) (L4)
3. a) Explain the merits and demerits of Branch Banking. (CO2) (L1)
(Or)
b) Evaluate the process of Commercial Bank management. (CO2) (L5)
4. a) What are the various assets in Banking Sector? (CO3) (L1)
(Or)
b) Explain the Non- performing assets on the profitability of Banks. (CO3) (L5)
5. a) Explain the importance of risk management in Banks. (CO4) (L1)
(Or)
b) Determine the recruitment and promotion policies followed in Nationalized Commercial Banks in India. (CO4) (L5)
6. a) Demonstrate the need and significance of computerization of accounts in Banks. (CO5) (L2)

(Or)

b) Build out the differences in the management of large sized branches and small branches. (CO5) (L3)

SECTION C - (1 x 10 = 10 marks)

Answer the following question.

7. a) Explain the salient features of Banking Regulation Act 1949. (CO3) (L2)

(Or)

b) Explain the role of Banks in the Economic Development of a Country. (CO5) (L2)



A. G & S.G. SIDDHARTHA DEGREE COLLEGE OF ARTS & SCIENCE

Vuyyuru-521165.

NAAC reaccredited at 'A' level

Autonomous -ISO 9001 – 2015 Certified

TITLE OF THE PAPER: FUNDAMENTALS OF GOODS AND SERVICES TAX

Semester: III

Course Code	GE04	Course Delivery Method	Class Room / Blended Mode - Both
Credits	2	CIA Marks	50
No. of Lecture Hours / Week	2	Semester End Exam Marks	--
Total Number of Lecture Hours	30	Total Marks	50
Practical Component	01 Hour/Week	Exam Hours	0
Year of Introduction:	Year of Offering: 2021 - 22	Year of Revision: ----	Percentage of Revision: 0%
CLASS:	II M.Com		

Course Outcomes:

CO-1 To equip the students with the concepts of GST

CO-2 To familiarize the students with GST Act.

CO-3 To offer in-depth knowledge on various types of GST

CO-3 To know the GST rates on various items for practical knowledge

CO-4 To understand Taxation of Services under GST

CO-5 To provide conceptual understanding about Inter-State Goods and Services Tax

FUNDAMENTALS OF GOODS & SERVICE TAX

Unit I: Introduction: Overview of GST - Concepts – Justification for introduction of GST - Shortcomings and advantages at the Central Level and State Level on introduction of GST- Process of Introduction of GST - Constitutional Amendments.

Unit-II: Taxes and Duties: Subsumed under GST - Taxes and Duties outside the purview of GST: Tax on items containing Alcohol – Tax on Petroleum products - Tax on Tobacco products - Taxation of Services

Unit-III: Inter-State Goods and Services Tax: Major advantages of IGST Model – Interstate Goods and Service Tax: Transactions within a State under GST – Interstate Transactions under GST - Illustrations.

References:

1. Goods and Services Tax in India – Notifications on different dates.
2. GST Bill 2012.
3. Background Material on Model GST Law, Sahitya Bhawan Publications, Hospital Road, Agra - 282 003.
4. The Central Goods and Services Tax Act, 2017, NO. 12 OF 2017 Published by Authority, Ministry of Law and Justice, New Delhi, the 12th April, 2017.

Guidelines to the paper setter

Marks	UNIT-I	UNIT-III	UNIT-IV
	Inrtoduction	Taxes and Duties	Inter-State Goods and Services Tax
5Marks	1	2	1
10Marks	2	2	2
Weight age	25	30	25

MODEL QUESTION PAPER
M.COM. (REGULAR) DEGREE EXAMINATION
Third Semester
GE 04: FUNDAMENTALS OF GOODS AND SERVICES TAX
(2021-2022 Regulation Onwards)

Duration: 2 hours

Maximum Marks: 50 marks

SECTION-A

I. Answer any TWO of the following

2x5=10M

1. What is GST?
2. What is IGST?
3. Subsumed under GST
4. Central GST

SECTION-B

II. Answer any FOUR of the following

4x10=40M

5. What are the advantages of Goods and Services Tax
6. What is the Comprehensive Structure of GST in India?
7. Explain the Taxes and Duties outside the Purview of GST
8. What are the advantages of IGST?
9. Explain about interstate transactions under GST
10. What is Time supply of goods and services?

**Adusumilli Gopalakrishnaiah & Sugarcane Growers
Siddhartha Degree College of Arts & Science (Autonomous)**

Vuyyuru-521 165, Krishna District, A.P.

--)00(--



Department of Zoology (Aquaculture)

Minutes of the meeting of Board of Studies

01.11.2021

Minutes of the meeting of Board of studies in Zoology for the Autonomous courses of AG & SG Siddhartha Degree College of Arts & Science, Vuyyuru, held at 2:30 pm on 01-11-2021 in the Department of Zoology.

Smt.D.A. Kiranmayee. ...

Presiding

Members Present:

- 1) Chair person Head, Department of Zoology,
(Smt. D.A.Kiranmayee.) A.G&S.G.S Degree College of
Vuyyuru-521165.
- 2)..... University Nominee Bio Sciences & Bio technology
(Smt. Dr.L.Suseela.) Krishna University
Machilipatnam.
- 3)..... Academic Council Head,Department of Zoology,
(Sri Dr.M.Viyay kumar.) Nominee SRR & CVR Govt. Degree College,
Vijayawada.
- 4)..... Academic Council Head, Department of Zoology,
(Sri Ch. Venkateswaralu.) Nomine P.B. Siddhartha College,
Vijayawada.
- 5)..... Member Lecturer in Zoology,
(Smt. K. Padmaja.) A.G&S.G.S Degree College
Vuyyuru-521165.
- 6)..... Industrialist Asst. Project Manager,
(B. Appala Naidu.) RGCA
Manikonda.
- 7)..... Student Represent P.hd –Research Scholar,
(Ch.Chiranjeevi.) Dept.of Botany & Microbiology,
Acharya Nagarjuna University,
Guntur.

AQUACULTURE

Agenda for B.O.S Meeting.

1. To recommend the syllabi (Theory & Practical), Model question paper for I Semester of I B.Sc (A.B.C) for the academic year 2021-2022.
2. To recommend the syllabi (Theory & Practical), Model question paper for III Semester of II B.Sc (A.B.C) for the academic year 2021-2022.
3. To recommend the syllabi (Theory & Practical), Model question paper for V Semester of III B.Sc (A.B.C) for the academic year 2021-2022.
4. To recommend the syllabi (Theory & Practical), Model question paper and Blue print of I, III & V semester of I, II, III B.Sc (A.B.C.) for the academic year 2021-2022.
5. To recommend the teaching and evolution methods to be followed under Autonomous statues.
6. Any other matter.

Chairman.

AQUACULTURE -RESOLUTIONS

1. It is resolved to continue the same syllabi (Theory & Practical), model question paper of I Semester of I B.Sc. (A.B.C) under Choice Based Credit System (CBCS) for the academic Year 2021 – 2022.
2. It is resolved to continue the same syllabi (Theory & Practical), model question paper of III Semester of II B.Sc. (A.B.C) under Choice Based Credit System (CBCS) for the academic Year 2021 – 2022.
3. It is resolved to continue the same syllabi (Theory & Practical), model question paper of V Semester of III B.Sc. (A.B.C) under Choice Based Credit System (CBCS) for the academic Year 2021 – 2022.
4. It is resolved to follow the Model question paper and Blue print of I,III & V semester of I,II & III B.Sc (A.B.C.) for the academic year 2021-2022.
5. It is resolved to continue the following teaching & evolution methods for the Academic year 2021-22.
6. Any other matter.

Teaching methods:

Besides the conventional methods of teaching, we use modern technology i.e. Using of OHP and LCD projector to display on U boards etc; for better understanding of concepts.

Evaluation of a student is done by the following procedure:

❖ **Internal Assessment Examination:**

- ❖ Out of maximum 100 marks in each paper for II & III B.Sc(A.B.C) 30 marks shall be allocated for internal assessment.
- ❖ Out of these 30 marks, 20 marks are allocated for announced tests (i.e . IA-1& IA-2). Two announced tests will be conducted and average of these two tests shall be deemed as the marks obtained by the student, 5 marks are allocated on the basis of candidate's percentage of attendance and remaining 5 marks are allocated for the assignment for I,II & III B.Sc (A.B.C).
- ❖ Out of maximum 100 marks in each paper for I B.Sc(A.B.C) 25 marks shall be allocated for internal assessment.
- ❖ Out of these 25 marks, 20 marks are allocated for announced tests (i.e . IA-1& IA-2). Two announced tests will be conducted and average of these two tests shall be deemed as the marks obtained by the student, 5 marks are allocated on the basis of candidate's percentage of attendance / assignment for I, semester.
- ❖ There is no pass minimum for internal assessment for I, II, III B.Sc

❖ **Semester – End Examination:**

- ❖ The maximum mark for I (ABC) semester – End examination shall be 75 marks and duration of the examination shall be 3 hours.
- ❖ The maximum mark for III, V (A.B.C) semester – End examination shall be 70 marks and duration of the examination shall be 3 hours. Even though the candidate is absent for two IA exams/ obtain Zero marks the external marks are considered (if the candidate gets 40/70) and the result shall be declared as “PASS”.
- ❖ Semester – End examination shall be conducted in theory papers at the end of every semester, while in practical papers, these examinations are conducted at the end of I, III & V semester for I, II & III B.Sc, (A.B.C).

- ❖ **Note: - Only for the semester I, we are following same syllabus, Question paper, Guidelines of P.B. Siddhartha Degree College & SDMS Mahila Kalasala.**

ALLOCATION OF CREDITS

Structure of AQUACULTURE Syllabus

For the Papers offered during I, III & V Semesters

<i>Year</i>	<i>Semester</i>	<i>Title</i>	<i>Teaching hours</i>	<i>Internal marks</i>	<i>External marks</i>	<i>Credits</i>
I	I	Principles of Aquaculture	4	25	75	03
		Practical - I	2	10	40	01
II	III	Fresh water & Brackish wter Aquaculture	4	30	70	03
		Practical -III	2	25	25	01
III	V(501)	Fish health Management	4	30	70	03
		Practical - 501p	2	25	25	01
	V(502)	Extension, Economics & Marketing	4	30	70	03
		Practical - 502p	2	25	25	01
		Total Credits				16

Annexure- I

**ADUSUMILLI GOPALAKRISHNAIAH & SUGAR CANE GROWERS SIDDHARTHA DEGREE COLLEGE
OF ARTS & SCIENCE, VUYYURU-521165, KRISHNA Dt., A.P. (AUTONOMOUS).**

NACC recredited at 'A' level
Autonomous –ISO 9001-2015 Certified

Title of the Paper: **Basic Principles of Aquaculture**

Semester: - I

Course Code	<i>AQUT11A</i>	Course Delivery Method	Class Room/Blended Mode - Both
Credits	3	CIA Marks	25
No. of Lecture Hours/ Week	4	Semester End Exam Marks	75
Total Number of Lecture Hours	60	Total Marks	100
Year of Introduction : 2017-18	Year of Offering 2021-2022	Year of Revision – 2021-22	Percentage of Revision: 0%

AIM

- To know the basic principles of Aquaculture.

OBJECTIVES

- To study the concept of blue revolution and its impact at global, national and state level.
- To get acquainted with different culture systems and culture methods.
- To study the different types of ponds used in culture practices.
- To study the criteria for construction of ideal fish pond.
- To study the management practices in fish/ prawn culture.

PREREQUISITE

- Knowledge of fisheries management acquired in Intermediate.

COURSE OUTCOMES

By the end of the course students will be able to

CO 1	Understand the concept of blue revolution, analyse the history and compare the present status of aquaculture at global, national and state levels and its significance over agriculture and gain knowledge in the various aquaculture resources and advantages of culture over capture.
CO 2	Acquire knowledge in the different types of aquaculture, culture systems and culture methods in practice worldwide.
CO 3	Gain knowledge in the different types of culture ponds.
CO 4	Understand the arrangement of different types of ponds in a fish farm and design an ideal fish farm.
CO 5	Comprehend the best management practices to be adopted in aquaculture for good yield and acquire the skill in the analysis of water and soil parameters of a culture pond.
CO 6	Identify the different types of weeds and predators in a culture pond and suggest the suitable control measures for their eradication.

Syllabus
Course Details

Unit	Learning Units	Lecture Hours
I	<p>UNIT-I (Introduction) Definition and History of Aquaculture Concept of Blue Revolution and Pradhan Mantri Matsya Sampada Yojana (PMMSY) Present status of Aquaculture at global level, India and Andhra Pradesh Aquaculture versus Agriculture; Present day needs with special reference to Andhra Pradesh Aquaculture resources: Ponds, tanks, lakes, reservoirsetc. Capture and Culture fisheries; Advantages of culture fishery over capture fishery</p>	11
II	<p>UNIT-II (Types of Fish Ponds) Lotic and lentic systems, streams and springs Classification of ponds based on water resources – spring, rain water, flood water, well water and water courseponds Functional classification of ponds – head pond, hatchery, nursery, rearing, production and stocking ponds; quarantine ponds, isolation ponds and wintering ponds Hatchery design</p>	11
III	<p>UNIT- III (Design and Construction of Aqua Farms) Important factors in the construction of an ideal fish pond – site selection, topography, nature of the soil, water resources Lay out and arrangement of ponds in a fishfarm Construction of an ideal fish pond – space allocation, structure and components of barrage Pond</p>	10
IV	<p>UNIT-IV (Aquaculture Systems and Practices) Types of aquaculture Fresh water aquaculture Brackish water aquaculture Mariculture Aquaculture Systems – Pond, Raceways, Cage, Pen, Rafts, Running water, Water Recirculating Systems, Biofloc Technology and 3-C System Pond culture practices- Traditional, Extensive, Modified Extensive, Semi-Intensive, Intensive & Super-intensive systems of fish and shrimp and their significance. Fin fish culture methods - Monoculture, Polyculture and Monosex cultureand Integrated fish farming.</p>	12
V	<p>UNIT-IV (Management Factors of Culture Ponds Pre-stocking Management Dewatering, drying, ploughing/desilting Liming and fertilization; Need of fertilizer and manure application, NPK contents of different fertilizers and manures and precautions in their Application Predators, weeds and weed fish in culture ponds - Advantages and disadvantages of weed plants; Toxins used for weed control and control of predators. Algal blooms and their control Stocking Management – Stocking density and stocking Post-stocking Management Feeding: Role of nutrients Water quality: Physico-chemical conditions of soil and water optimum for culture – temperature, depth, turbidity, light, water and shore currents, PH, DOD, CO₂,</p>	14

NH ₃ , NO ₂ and nutrients	
---	--

. Measures to increase oxygen and reduce ammonia & hydrogen sulphide in culture ponds; correction of PH

PRESCRIBED BOOK(S):

1. Jhingran VG 1998. Fish and Fisheries of India. Hindusthan Publishing Corporation, New Delhi
2. Pillay TVR, 1996. Aquaculture Principles and Practices, Fishing News Books Ltd., London

REFERENCES:

1. Pillay TVR & M.A. Dill, 1979. Advances in Aquaculture. Fishing News Books Ltd., London
2. Stickney RR 1979. Principles of Warm Water Aquaculture. John Wiley & Sons Inc. 1981
3. Boyd CE 1982. Water Quality Management for Pond Fish Culture. Elsevier Scientific Publishing
4. Bose AN et al, 1991. Coastal Aquaculture Engineering. Oxford & IBH Publishing Company.

CO-CURRICULAR ACTIVITIES

1. Collection of data on present status of aquaculture
2. Animal album-making
 - a. Plankton
 - b. Aquatic weeds
 - c. Aquatic Insects
 - d. Algal Blooms
 - e. Weed and Predatory fish
3. Preparation of clay models of different ponds in a fish farm.
4. Field survey of nearby habitat for dietary dependency on and requirement of aqua-products
5. Collection of water and soil samples and estimation of various parameters.
6. Preparation of charts on aeration devices.
7. Collection of different culture species stage-wise {spawn, fry, fingerlings, zero size and adult (more than 200 g)}

I SEMESTER END EXAMINATIONS

PAPER – I

MODEL PAPER

Course Code: AQUT11A

Title of the paper: Basic Principles of Aquaculture

Time: 3 Hours

Max. Marks: 75

SECTION –A

Draw neat labeled diagrams wherever necessary.

Answer and FIVE of the following

5x5=25 Marks

1. Explain the significance of Biofloc Technology CO2, L2
2. Explain the concept of blue revolution CO1, L2
3. What is Mari culture? CO2, L1
4. Explain the importance of pond fertilization. CO5, L2
5. Explain the functional role of Rearing and Stocking ponds CO3, L2
6. Mention the criteria for site selection of an ideal fish pond CO4, L1
7. Analyze the control measures for weed fish in culture ponds CO6, L4
8. Justify the role of nutrients in a fish pond. CO5, L5

SECTION – B

Answer the following questions.5X10=50 Marks

9. Define capture and culture fisheries. List out the advantages of culture fishery over capture fishery.

CO1, L1

OR

Mention the present status of Aquaculture at global level, India and Andhra Pradesh. CO1, L1

10. Explain the different types of freshwater aquaculture. CO2, L2

OR

Describe the different types of pond culture methods. CO2, L2

11. Give an account of the different types of hatcheries and describe the design of a modern hatchery.

CO4, L2

OR

Classify ponds based on water resources. CO4, L2

12. Describe the structure and components of a barrage pond. CO4, L1

OR

Describe the lay out and arrangement of nursery pond in a fish farm. CO4, L1

13. Analyze the physico-chemical conditions of water optimum for fish culture. CO5, L4

OR

Write an essay on aquatic weed plants in a fish pond, their advantages and disadvantages. CO6, L4

PRACTICAL- I (At the end of I Semester)

Title of the paper: Basic Principles of Aquaculture.

No of Hours: 30
WEF: 2021-2022

Credits: 01
Course Code:AQU P11A

LEARNING OUTCOMES:

By the end of the course students will be able to

- Identify the various live food organisms in the culture ponds.
- Identify the aquatic weeds, insects and weed fish causing damage to the cultured animals and suggest measures to control the algal blooms in culture ponds.
- Understand the mechanism of aeration devices used in culture ponds.
- Develop skill in analysing the various water and soil parameters.
- Gain practical knowledge in the management of different types of ponds in a fish farm.
- Understand the importance of preservation of museum specimens and identify the animals based on special identifying characters.
- Maintain a neat, labeled record of identified museum specimens and exhibit the hidden creative talent.
 1. Estimation of Carbonates, Bicarbonates in water samples
 2. Estimation of Chlorides in water samples
 3. Estimation of Dissolved Oxygen
 4. Estimation of Ammonia in water.
 5. Estimation of Total Hardness of water sample.
 6. Determination of soil Nitrogen and Phosphorus.
 7. Study of beneficial and harmful algal species
 8. Study of aeration devices
 9. Collection, identification and isolation of zooplankton and phytoplankton
 10. Collection and study of aquatic weeds, aquatic insects, weed fish and larvivorous fish
 11. Study of fish species banned from culture (*Clarius gariepinus*, *Hypostomus plecostomus*)
 12. Field visit to hatchery, nursery, rearing and stocking ponds of aqua farms.

PRESCRIBED BOOK(S):

1. Jhingran VG 1998. Fish and Fisheries of India, Hindustan Publishing Corporation, New Delhi
2. Pillay TVR, 1996. Aquaculture Principles and Practices, Fishing News Books Ltd., London

REFERENCES

1. Boyd CE. 1979. *Water Quality in Warm Water Fish Ponds*. Auburn University
2. Boyd, CE. 1982. *Water Quality Management for Pond Fish Culture*. Elsevier Sci. Publ. Co.
3. FAO. 2007. *Manual on Freshwater Prawn Farming*.
4. ICAR. 2006. *Hand Book of Fisheries and Aquaculture*. ICAR.
5. Lovell RT. 1998. *Nutrition and Feeding of fishes*. Chapman & Hall.
6. Mcvey JP. 1983. *Handbook of Mariculture*. CRC Press.
7. MPEDA: *Handbooks on culture of carp, shrimp, etc.*
8. Bose AN et al., 1991. *Costal Aquaculture Engineering*. Oxford & IBH Publishing Company Pvt. Ltd.
9. Stickney RR 1979. *Principles of Warm Water Aquaculture*. John Wiley & Sons Inc. 1981
10. Pillay TVR & M.A. Dill, 1979. *Advances in Aquaculture*. Fishing News Books Ltd., London

I B.Sc AQUACULTURE PRACTICAL EXAMINATION

Practical - I

Course Code: AQU P11A

Title of the paper: Basic Principles of Aquaculture

Time: 3hrs.

Max. Marks 40M

I. Estimate the amount of Chlorides/ Dissolved Oxygen/Free Carbon dioxide /Total Hardness of the given sample. CO4, L5 **10 M**

Procedure: 5M

Calculations: 3M

Report: 2M

II. Identify, draw labelled diagram, classify and comment on CO1, CO2, CO6, L3 **5x3=15 M**

A. Algal Blooms

Identification : 1M

B. Plankton

Diagram :1/2 M

C. Aquatic weed

Notes : 11/2M

D. Aquatic Insect

E. Weed Fish

III. Practical Record Book CO7, L3 **5M**

IV. Field note Book CO5, L1 **5M**

V. VIVA CO7, L5 **5M**

**ADUSUMILLI GOPALAKRISHNAIAH & SUGAR CANE GROWERS SIDDHARTHA DEGREE COLLEGE
OF ARTS & SCIENCE, VUYYURU-521165, KRISHNA Dt., A.P. (AUTONOMOUS).**

NACC reaccredited at 'A' level
Autonomous –ISO 9001-2015 Certified

Title of the Paper: **Fresh water & Brackish water Aquaculture**

Semester: - III

Course Code	<i>AQU-301C</i>	Course Delivery Method	Class Room/Blended Mode - Both
Credits	3	CIA Marks	30
No. of Lecture Hours/ Week	4	Semester End Exam Marks	70
Total Number of Lecture Hours	60	Total Marks	100
Year of Introduction : 2017-18	Year of Offering 2021-2022	Year of Revision – 2021-22	Percentage of Revision: 0%

Objective of the course: The students understand Fresh water & Brackish water Aquaculture.

Course outcomes:

CO1: Learn the Status, Scope and Prospects of fresh water aquaculture in the world, India and AP.

CO2: Learn about Major Cultivable Indian Carps and Exotic fish Species introduced in India

CO3: Know about recent developments in the culture of clarius, anabas and murrels and special systems of aquaculture.

CO4: Gain knowledge of commercially valuable Fresh water prawns of India and their culturing methods.

CO5: Learn about culturing of brackish water Prawn Species *P.mondon* and *L.vannamei* and hatchery technology's involved

Learning Objectives:

- To know the present status of freshwater and brackish water aquaculture and their role in world economy and food production.
- To gain knowledge on carp, prawn, shrimp and crab culture and composite fish culture systems.
- To improve the technical knowledge on fish and shrimp hatchery technology and culture practices.
- To improve the knowledge and technical skills for the identification of cultivable fin fish and shell fish.

Syllabus
Course Details

Unit	Learning Units	Lecture Hours
I	UNIT- I: Introduction Status, scope and prospects of freshwater aquaculture in the world, India and AP Status, scope and prospects of brackish water aquaculture in the world, India and AP Freshwater and brackish water resources in India. Special culture systems - brief study of culture in running water, recirculatory systems, cages and pens, sewage-fed fish culture.	10
II	UNIT-II: Culture of carp, air-breathing, and exotic fishes Bundh breeding and Induced breeding of Indian major carp by hypophysation technique .Synthetic harmones used for induced breeding of carps. Types of fish hatcheries- traditional, Chinese and jar hatcheries. Preparation and Management of Indian major carp culture ponds – nursery, rearing and grow-out ponds. Culture of air-breathing fishes in India; Pangasius fish farmin Exotic fishes introduced to India and their impact on indigenous species. Composite fish culture of Indian and exotic carps – compatibility and competition.	10
III	UNIT-III: Culture of prawn and ornamental fishes Breeding and hatchery management of freshwater prawn, Macrobrachium rosenbergii. Culture of Macrobrachium rosenbergii and M. malcolmsonii – biology, seed production, pond preparation, stocking, management, feeding, morph types and harvesting. Ornamental fish culture– Common freshwater and marine ornamental fishes; Fabrication, setting up and maintenance of freshwater and marine aquarium. Breeding and rearing of freshwater ornamental fishes.	15
IV	UNIT-IV: Culture of shrimp and crab Breeding and Hatchery management of a typical penaeid shrimp (Penaeus monodon or Litopenaeus vannamei) Transportation of shrimp seed and nursery management. Culture of P. mondon or L. vannamei –pond preparation, stocking, management of water, feedand diseases, and harvesting. Culture of mud crab, Scylla serrata.	15
V	UNIT-V: Culture of brackish water fishes Breeding and Culture of milk fish, Chanos chanos. Breeding and Culture of Asian sea bass, Lates calcarifer. Breeding and Culture of grey mullet, Mugil cephalus. Fish and shellfish culture in cages and pens.	10

*A.G. & S.G.Siddhartha Degree College of Arts & Science, Vuyyuru – 521165, Krishna Dt. A.P.
(Autonomous)*

Semester –III

w.e.f. 2021-2022

Time: 3hrs (Model question paper)

Title of the paper: Fresh water & Brackish water Aquaculture.

Code – AQU-301C

max.marks: 70

Section – A

Answer any **four** questions. Each question carries **five** marks.

4 x 5 = 20.

Draw neat labeled diagrams wherever necessary.

1. Freshwater culture systems
2. Cages
3. Bundh breeding
4. Nursery pond
5. Seed production
6. Feed and diseases
7. Harvesting
8. chanos chanos

Section – B

Answer any **five** questions. Each question carries **Ten** marks.

5 x 10 = 50

Draw neat labeled diagrams wherever necessary.

9. Describe the status and prospects of freshwater aquaculture in A.P.?
10. Write an essay on major cultivable Indian carps
11. Explain recent culture trends in murrels
12. . Describe composite fish culture system of Indian and exotic carps
13. Explain advantages in the culture of air-breathing fishes.
- 14 Write an essay on the commercial value of Indian freshwater prawn.
15. Breeding and Culture of milk fish

A.G & S.G.S.DEGREE COLLEGE OF ARTS & SCIENCE, VUYURU 521165, KRISHNA Dt., A.P.
(AUTONOMOUS)

SEMESTER-III

Guide lines to the paper setter

Time: 3 hrs

Max.Marks:70

Paper Title: - Fresh water & Brackish water Aquaculture.

Paper Code: AQU-301C

Note: 1. Answer **any four** questions out of eight in Part-A. Each question carries five marks. 4X 5 = 20M.

2. Answer any **five** questions out of eight in Part-B. Each question carries 10 marks. 5 X 10 = 50M.

	PART	Unit –I	Unit – II	Unit-III	Unit – IV	Unit – V
5 Marks Questions	A	1	2	2	2	1
10 Marks Questions	B	1	2	2	1	2
Weightage		15	30	30	20	25

Note: 1. please provide the scheme of valuation for the paper.

2. Question paper should be both in English and Telugu media.

Code: AQU- 301P
(2hrs/week)

w.e.f. 2021-2022.
MAX.MARKS: 50.

PRACTICAL SYLLABUS

1. Identification of important cultivable carps.
2. Identification of important cultivable air-breathing fishes.
3. Identification of important cultivable fresh water prawns.
4. Identification of different life history stages of fish.
5. Identification of different life history stages of fresh water prawn Collection and study of weed fish.
6. Identification of commercially viable crabs – *Scylla cerrata*, *Portunus pelagicus*, *P.sanguinolentus*, *Neptunus pelagicus*, *N. Sanguinolentus* .
7. Identification of lobsters – *Panulirus polyphagus*, *P.ornatus*, *P.homarus*, *P.sewelli*, *P.penicillatus*.
8. Identification of oysters of nutritional significance – *Crossostrea madrasensis*, *C.gryphoides*, *C. cucullata*, *C.rivularis* , *Picnodanta* .
9. Identification of mussels and clams.
10. Identification of developmental stages of oysters.
- 11 .Field visit to aqua farm and study of different components like dykes etc.

PRESCRIBED BOOK(S):

1 Jhingran VG 1998. Fish and Fisheries of India. Hindusthan Publishing Corporation, New Delhi

REFERENCES:

1. Santharam R, N Sukumaran and P Natarajan 1987. A manual of aquaculture, Oxford-IBH, New Delhi .
2. Srivatsava 1993. Fresh water aquaculture in India, Oxford-IBH, New Delhi Marcel H 1972. Text book of fish culture.Oxford fishing news books.

Practical - III

w.e.f. 2021 - 2022

Model Question Paper (External)

Max. Marks: 25

Paper Code: AQU-301P

I. Nutrition:

1. Identify, draw labeled diagram & write notes on important cultivable carps. 2x2=4
A & B
2. Identify, draw labeled diagram & write notes on air-breathing fishes. 2x2=4
A & B
- 2 Identify, draw labeled diagram & write notes on. Important cultivable fresh water prawns. 2x2=4
A & B
1. Identification of commercially viable crabs 2x2=4
A & B
6. Identify, draw labeled diagram & write notes on 3X2=06
A, B, C,
7. Identification of developmental stages of oysters 3 M

Total-----25m

Guide lines for the practical Examiners

1. ½ Mark for identification, ½ Mark for labeled diagram & 1 Mark for notes for each question.
(2 specimens / slides / models.)
2. ½ Mark for identification, ½ Mark for labeled diagram & 1 Mark for notes for each question.
(2 specimens / slides / models.)
3. ½ Mark for identification, ½ Mark for labeled diagram & 1 Mark for notes for each question.
(2 specimens / slides / models.)
4. ½ Mark for identification, ½ Mark for labeled diagram & 1 Mark for notes for each question.
(2 specimens / slides / models.)
5. ½ Mark for identification, ½ Mark for labeled diagram & 1 Mark for notes for each question.
(2 specimens / slides / models.)
6. ½ Mark for identification, ½ Mark for labeled diagram & 2 Mark for notes for each question.
(3 specimens / slides / models.)
7. Labeled diagrams 1 mark & 2 marks for notes (3marks)

A. G.& S.G. SIDDHARTHA DEGREE COLLEGE OF ARTS & SCIENCE, VUYYURU-521165

INTERNAL PRACTICAL- III

**w.e.f. 2021-2022.
(2 hrs/week).**

Code: AQU-301P.

Max.marks:25M.

**(Practical -III)
MODEL QUESTION PAPER -III**

Time: 3hrs.

- | | | | |
|----|------------------|-------|------|
| 1. | Attendance | ----- | 05M. |
| 2. | Record | ----- | 10M. |
| 3. | Field note book. | ----- | 05M |
| 4. | Assignment | ----- | 05M. |

Total ----- 25M.

**ADUSUMILLI GOPALAKRISHNAIAH & SUGAR CANE GROWERS SIDDHARTHA DEGREE COLLEGE
OF ARTS & SCIENCE, VUYYURU-521165, KRISHNA Dt., A.P. (AUTONOMOUS).**

NACC reaccredited at 'A' level
Autonomous –ISO 9001-2015 Certified

Title of the Paper: **Fish health management**

Semester: - V

Course Code	<i>AQU-501C</i>	Course Delivery Method	Class Room/Blended Mode - Both
Credits	3	CIA Marks	30
No. of Lecture Hours/ Week	4	Semester End Exam Marks	70
Total Number of Lecture Hours	60	Total Marks	100
Year of Introduction : 2019	Year of Offering 2021-2022	Year of Revision – 2021-22	Percentage of Revision: 0%

Objective of the course: The students understand Fresh health management and Diseases of fishes.

Course outcomes:

CO1: Provide students with knowledge about fish diseases and pathological aspects of diseases.

CO2: Learn about Fungal, Viral and Bacterial diseases of finfish.

CO3: Learn about major shrimp viral, bacterial and protozoan diseases and prevention and therapy methods.

CO4: Gain knowledge of Nutritional deficiency related diseases and antibiotic and chemotherapeutics.

CO5: Understand and learn the importance of diagnostic tools in identification of diseases and application and development of vaccines. To know about production of disease free seeds and good feed management.

Learning Objectives:

- To understand the principles of disease diagnosis and fish health management.
- To know the prophylactic and therapeutic methods to control the diseases.
- To understand the defence mechanism and immune system in fish and shrimp.
- To gain detailed knowledge on the disease symptoms, causative agent, preventive measures and treatment for microbial, parasitic, nutritional and environmental disorders in fish and shrimp.
- To understand the diagnosis tools that is followed in field of aquaculture and vaccine production for fish immunization.

Syllabus
Course Details

Unit	Learning Units	Lecture Hours
I	<p>UNIT I: Pathology and parasitology Introduction to fish diseases –Definition and categories of diseases – Disease and environment Disturbance in cell structure – changes in cell metabolism, progressive and retrogressive tissue changes, types of degeneration, infiltration, necrosis, cell death and causes Atrophy, hypertrophy, neoplasms, inflammation, healing and repair</p>	10
II	<p>UNIT II: Diseases of fin fish. Fungal diseases (both of shell and finfish) – Saprolegniosis, brachiomycosis, ichthyophorus diseases – Lagenidium diseases – Fusarium disease, prevention and therapy Viral diseases – Emerging viral diseases in fish, haemorrhagic septicemia, spring viremia of carps, infectious hematopoietic necrosis in trout, infectious pancreatic necrosis in salmonids, swim-bladder inflammation in cyprinids, channel cat fish viral disease, prevention and therapy Bacterial diseases – Emerging bacterial diseases, aeromonas, pseudomonas and vibrio infections, columnaris, furunculosis, epizootic ulcerative syndrome, infectious abdominal dropsy, bacterial gill disease, enteric red mouth, bacterial kidney disease, proliferative kidney disease, prevention and therapy</p>	15
III	<p>UNIT III: Diseases of shell fish Major shrimp viral diseases – Baculovirus penaei, Monodon Baculovirus, Baculoviral midgut necrosis, Infectious hypodermal and haematopoietic necrosis virus, Hepatopancreatic parvo like virus, Yellow head baculovirus, white spot baculovirus. Bacterial diseases of shell fish – aeromonas, pseudomonas and vibrio infections, luminous bacterial disease, filamentous bacterial disease. Prevention and therapy Protozoan diseases- Ichthyophthiriasis, Costiasis, whirling diseases, trypanosomiasis Prevention and therapy</p>	12
IV	<p>UNIT IV: Nutritional diseases Nutritional pathology – lipid liver degeneration, Vitamin and mineral deficiency diseases. Aflatoxin and dinoflagellates. Antibiotic and chemotherapeutics. Nutritional cataract. Genetically and environmentally induced diseases</p>	8
V	<p>UNIT V: Fish health management Diagnostic tools – immune detection- DNA/RNA techniques, General preventive methods and prophylaxis. Application and development of vaccines. Quarantine – Significance, methods and regulations for transplants. Production of disease-free seeds. Evaluation criteria of healthy seeds. Good Feed management for healthy organisms, Zero water exchange, Probiotics in health management, Issues of bio security.</p>	15

**A.G. & S.G.Siddhartha Degree College of Arts & Science, Vuyyuru – 521165, Krishna Dt.
A.P. (Autonomous)**

Semester –V
(Model question paper)

w.e.f. 2021-2022

Title of the paper: Fish health management.
Time: 3hrs.

Code – AQU-501C
max.marks: 70

Section – A

4 x 5= 20.

Answer any **four** questions. Each question carries **five** marks. Draw neat labelled diagrams wherever necessary.

1. Necrosis.
2. Atrophy
3. Lagenidium diseases
- 4 Bacterial kidney diseases.
5. Monodon Bacculovirus
6. Yellow head bacculovirus
7. Lipid liver degeneration
- 8, Zero water exchange.

Section – B

5 x 10 =50.

Answer any **five** questions. Each question carries **Ten** marks. Draw neat labelled diagrams wherever necessary.

9. Write an essay on any two nutritional Requirements for cultivable fish?
10. Explain the changes in cell metabolism?
11. Explain about Bacterial diseases of shell fish?
12. Explain about channel cat fish viral disease prevention and therapy?
13. Describe the Protozoan diseases??
14. Write an essay on genetically and environmentally induced diseases?
15. Explain about application and development of vaccines?
16. Methods and regulations for transplants?

**A.G. & S.G. Siddhartha Degree College of Arts & Science, Vuyyuru – 521165,
Krishna Dt. A.P. (Autonomous)**

**Semester - V
Guide lines to the Paper Setter.**

Title of the paper: Fish health management

Time: 3hrs.

W.e.f. 2021-2022

Code – AQU-501C

Max. Marks: 70.

1. Answer any **four** questions out of eight in Section – A. Each question carries five marks. 4x5 = 20M.

2. Answer any **five** questions out of eight in Section – B. Each question carries Ten marks. 5x10= 50M.

	Section	UNIT-I	UNIT-II	UNIT-III	UNIT-IV	UNIT-V
5 Marks Questions	A	2	2	2	1	1
10 Marks Questions	B	1	2	2	1	2
Weightage		20	30	20	20	25

Note: 1. please provide the scheme of valuation for the paper.

2. Question paper should be in English medium.

Code: AQU- 501P
(2hrs/week)

w.e.f. 2021-2022.
MAX.MARKS: 50.

PRACTICAL SYLLABUS

1. Enumeration of Bacteria by TPC Method
2. Enumeration of total Coli forms
3. Observation of gross pathology and external lesions of fish and prawn with reference to the common diseases in aquaculture
4. Examination of pathological changes in gills and gut lumen, lymphoid organ, muscles and nerves of fish
5. Examination of pathological changes in gut lumen, hepatopneacas, lymphoid organ, muscles and nerves of prawn and shrimp
6. Collection, processing and analysis of data for epidemiological investigations of viral diseases
7. Bacterial pathogens – isolation, culture and characterization
8. Identification of parasites in fishes: Protozoan, Helmiths, Crustaceans
9. Antibiograms – preparation and evaluation
10. Molecular and immunological techniques; Biochemical tests; PCR; ELISA; Agglutination test; Challenge tests; Purification of virus for development of vaccines (Demonstration at institutes/labs)
11. Estimation of dose, calculation of concentration, methods of administration of various chemotherapeutics to fish and shell fish
12. Estimation of antibiotics used in aquaculture practices
13. Estimation of probiotics used in aquaculture
14. Field visit to farm for health monitoring and disease diagnosis

PRESCRIBED BOOK(S):

1. Shaperclaus W. 1991 Fish Diseases- Vol.I & II. Oxonian Press Pvt.ltd
2. Roberts RJ 1989. Fish pathology. Bailliere Tindall, New York
3. Lydia Brown 1993. Aquaculture for veterinarians- fish husbandray and medicine. Pergamon Press. Oxford

REFERENCES:

1. Shankar KM & Mohan CV. 2002. Fish and Shellfish Health Management. UNESCO Publ. Sindermann CJ. 1990
2. Walker P & Subasinghe RP. (Eds.). 2005 Principal Diseases of Marine Fish and Shellfish. Vols. I, II. 2nd Ed. Academic Press
3. DNA Based Molecular Diagnostic Techniques: Research Needs for Standardization and Validation of the Detection of Aquatic Animal Pathogens and Diseases. FAO Publ. Wedmeyer G, Meyer FP & Smith L. 1999.
4. Bullock G et.al., 1972 Bacterial diseases of fishes. TFH publications, New Jersey
5. Post G 1987. Text book of Fish Health. TFH publications, New Jersey
6. Johnson SK 1995. Handbook of shrimp diseases. Texas A & M University, Texas

A. G.& S.G. SIDDHARTHA DEGREE COLLEGE OF ARTS & SCIENCE, VUYYURU-521165

EXTERNAL PRACTICAL- V

(2hrs/week)

MODEL QUESTION PAPER -V

w.e.f. 2021-2022.

Code: AQU-501P

Time: 3 hrs.

Max.marks: 25m.

- | | |
|--|--------|
| I. Estimation of antibiotics used in aquaculture practices | 5M. |
| II. Biochemical tests | 5M. |
| III. ELISA; | 5M |
| IV. Identify, draw labelled diagram & write notes on
A, B, C, D | 5X2=10 |

V.

TOTAL: -----

25M.

Guide lines for the practical Examiners

- I: Estimation of carbohydrate content in aquaculture feeds (4 marks notes & Result 1 mark.)
- II: Biochemical tests. (5 marks notes)
- III: ELISA (5 marks notes)
- IV. ½ Mark for identification, ½ Mark for labeled diagram & 2 Mark for notes for each question.
- 4 specimens / slides / models.

A. G.& S.G. SIDDHARTHA DEGREE COLLEGE OF ARTS & SCIENCE, VUYYURU-521165

INTERNAL PRACTICAL-V

w.e.f. 2021-2022.

(2 hrs/week).

Code: AQU-501P.

MODEL QUESTION PAPER -V

Max.marks:25M.

Time: 3hrs.

- | | | |
|---------------|-------|------|
| 1. Attendance | ----- | 05M. |
| 2. Record | ----- | 10M. |
| 3. Field trip | ----- | 10M |

Total ----- 25M.

**ADUSUMILLI GOPALAKRISHNAIAH & SUGAR CANE GROWERS SIDDHARTHA DEGREE COLLEGE
OF ARTS & SCIENCE, VUYYURU-521165, KRISHNA Dt., A.P. (AUTONOMOUS).**

NACC reaccredited at 'A' level
Autonomous –ISO 9001-2015 Certified

Title of the Paper: **Extension, Economics & Marketing**

Semester: - V

Course Code	<i>AQU-502C</i>	Course Delivery Method	Class Room/Blended Mode - Both
Credits	3	CIA Marks	30
No. of Lecture Hours/ Week	4	Semester End Exam Marks	70
Total Number of Lecture Hours	60	Total Marks	100
Year of Introduction : 2019	Year of Offering 2021-2022	Year of Revision – 2021-22	Percentage of Revision: 0%

Objective of the course: The students understand Extension, Economics & Marketing aspect of fisheries and aquaculture and help the students in applying their theoretical knowledge into practical in order to be self reliance and to be a good pace setters in the business world.

Course outcomes:

CO1: Gain the Knowledge of basic concepts of economics with reference to fisheries and various factors influencing the fishery products price.

CO2: Will come to know about fisheries marketing, methods of economic analysis of business organizations and preparation of project and project appraisal.

CO3: To know about application of economic principles to aquaculture operations.

CO4: Get the broad knowledge of scope and objectives, principles of fisheries extension.

CO5: Understand the importance of transfer technology of ICAR programmes and training at DAATT Centres and their role in education of aqua farmers through print and electronic media.

Learning Objectives:

- To explain fisheries economics and marketing.
- To understand economics constraints in fisheries development, free access to fisheries, sustainable yield curve and total revenue curve, bio economic equilibrium, factor rents welfare economic theory and its relevance for fisheries externalities.
- To understand fisheries extension methods and rural development
- Write Feasibility report

Syllabus
Course Details

Unit	Learning Units	Lecture Hours
I	<p>UNIT – 1 Introduction Meaning and scope of economics with reference to fisheries Basic concepts of economics – goods, services, wants and utility, demand and supply, value price, market demand and individual demand, elasticity of demand, law of diminishing marginal utility Theory of production, production function in fisheries Various factors influencing the fishery product's price.</p>	10
II	<p>UNIT – II Fisheries marketing Basic marketing functions, consumer behavior and demand, fishery market survey and test marketing a product Fish marketing – prices and price determination of fishes Marketing institutions- primary (producer fishermen, fishermen cooperatives, and fisheries corporations) and secondary (merchant/agent/speculative middlemen) Methods of economic analysis of business organizations Preparation of project and project appraisal</p>	15
III	<p>UNIT-III Fisheries economics Aquaculture economics- application of economics principles to aquaculture operations Various inputs and production function. Assumptions of production function in aquaculture analysis, least cost combination of inputs, laws of variable proportions 3Cost and earnings of aquaculture systems – carp culture, shrimp farming systems, hatcheries, Cost and earnings of fishing units and freezing plants Socio-economic conditions of fishermen in Andhra Pradesh, Role of Matsyafed and NABARD in uplifting fishermen's conditions, fishermen cooperatives Contribution of fisheries to the national economy</p>	15
IV	<p>UNIT-IV Fisheries extension Fisheries extension – scope and objectives, principles and features of fisheries extension education Fisheries extension methods and rural development Adoption and diffusion of innovations</p>	10
V	<p>UNIT-V Transfer of technology ICAR programs – salient features of ORP, NDS, LLP, IRDP, ITDA, KVK, FFDA, FCS, FTI, TRYSEM Training – meaning, training vs. education and teaching DAATT centers and their role in tot programs, video conferencing, education of farmers through print and electronic media.</p>	15

Semester –V
(Model question paper)

w.e.f. 2021-2022

Title of the paper: Extension, Economics & Marketing
Time: 3hrs.

Code – AQU-502C
max.marks: 70

Section – A

4 x 5= 20.

Answer any **four** questions. Each question carries **five** marks. Draw neat labelled diagrams wherever necessary.

1. Demand and supply.
2. Goods
3. Consumer behaviour
4. Preparation of project
5. NABARD
6. Scope and objectives
7. IRDP
8. Salient features of ORP

Section – B

5 x 10 =50.

Answer any **five** questions. Each question carries **Ten** marks. Draw neat labelled diagrams wherever necessary.

9. Write an essay on any two nutritional Requirements for cultivable fish?
10. Explain the market demand and individual demand?
11. Explain about production function in fisheries?
12. Give an account of Marketing institutions?
13. Methods of economic analysis of business organizations?
14. Write an essay on shrimp farming systems?
15. Explain about Fisheries extension methods and rural development?
16. DAATT centers and their role in tot programs?

*A.G. & S.G. Siddhartha Degree College of Arts & Science, Vuyyuru – 521165,
Krishna Dt. A.P. (Autonomous)*

*Semester - V
Guide lines to the Paper Setter.*

Title of the paper: Extension, Economics & Marketing

Time: 3hrs.

*W.e.f. 2021-2022
Code – AQU-502C*

Max. Marks: 70.

1. Answer any **four** questions out of eight in Section – A. Each question carries five marks. 4x5 = 20M.

2. Answer any **five** questions out of eight in Section – B. Each question carries Ten marks. 5x10= 50M.

	Section	UNIT-I (Pr	UNIT-II	UNIT-III	UNIT-IV	UNIT-V
5 Marks Questions	A	2	2	1	1	2
10 Marks Questions	B	2	2	2	1	1
Weightage		30	30	25	20	25

Note: 1. please provide the scheme of valuation for the paper.

2. Question paper should be in English medium.

A.G. & S.G.SIDDHARTHA DEGREE COLLEGE OF ARTS & SCIENCE, VUYYURU-521165, KRISHNA Dt.,A.P.
(AUTONOMOUS)
AQUACULTURE
PRACTICAL - VI

Code :AQU- 502P
(2hrs/week)

w.e.f. 2021-2022.
MAX.MARKS : 50.

PRACTICAL SYLLABUS

PRACTICAL:

Project work/on-job training at industry.

PRESCRIBED BOOK(S):

1. Adivi Reddy sv 1997. An introduction to extension education. Oxford & IBH Co.Pvt. Ltd. New Delhi
2. Jayaraman R 1996. Fisheries Economics. Tamilnadu Veterinary and Animal Science University. Tuticorn
3. Subba Rao N 1986. Economics of Fisheries. Daya publishing house, Delhi

REFERENCES:

1. Dewwett KK and Varma JD 1993. Elementary economic theory. S.chand, New Delhi
2. Korakandy R 1996. Economics of Fisheries Mangement. Daya Publishing House, Delhi
3. Tripathi SD 1992. Aquaculture Economics. Asian Fisheries Society, Mangalore.



AG & SG Siddhartha Degree College of Arts & Science (Autonomous)

Vuyyuru – 521165, Krishna District, AP.

Accredited 'A' Grade by NAAC



Department of Statistics

Minutes of the meeting of Board of Studies

12-11-2021

Minutes of the meeting of BOS in Statistics for B. Sc (MSCs) Degree Courses of AG & SG Siddhartha Degree College of Arts & Science, Vuyyuru, held at 3.00 PM on 12 – 11 – 2021.

N.V. Srinivasa Rao

Presiding

Members Present:

- | | | |
|---|--------------------|--|
| 1) <u><i>N.V. Srinivasa Rao</i></u>
(N.V. Srinivasa Rao) | Chairman | Head, Department of Mathematics,
AG & SG S Degree College. |
| 2) <u><i>R. Ravi Kumar</i></u>
(R. Ravi Kumar) | University Nominee | Department of Statistics,
Pavitra Degree College,
Machilipatnam. |
| 3) <u><i>G. Chakravarthy</i></u>
(G. Chakravarthy) | Subject Expert | Head. Department of Statistics,
P. B. Siddhartha College,
Vijayawada |
| 4) <u><i>D. Sunitha</i></u>
(D. Sunitha) | Member | Lecturer in Mathematics
AG & SG S Degree College. |
| 5) <u><i>A. Bhargava</i></u>
(A. Bhargava) | Member | Lecturer in Mathematics
AG & SG S Degree College. |
| 6) <u><i>Noor Mohammad</i></u>
(Noor Mohammad) | Member | Lecturer in Mathematics
AG & SG S Degree College. |
| 7) <u><i>K. Rajya Lakshmi</i></u>
(K. Rajya Lakshmi) | Member | Lecturer in Mathematics
AG & SG S Degree College. |

Agenda of B.O.S Meeting:

1. To discuss and recommend the Syllabi, Model Question Papers and Guidelines to be followed by question paper setters in Statistics for 1st Semester as per the guidelines and instructions under CBCS prescribed by Krishna University from the Academic Year 2021-22.
2. Any other matter.

Resolutions.

1. Discussed and recommended that changes are required in Syllabi, Model Question Papers and Guidelines to be followed by the question paper setters in Statistics for 1st Semesters from the Academic year 2021-22. The maximum marks for IA is 25 and SE is 75. Each IA written examination is of 1 Hr. 30 min duration for 20 marks. The tests will be conducted centrally. The average of two such IA is calculated for 20 marks. 5 marks will be allotted basing on Assignment. There is no minimum passing for IA and there is no provision for improvement in IA. Even though the candidate is absent for two IA exams/obtain zero marks the external marks are considered (if he/she gets 40 out of 75) and the result shall be declared as 'PASS' from the Academic year 2021-22.
2. Discussed and recommended for organizing seminars, Guest lecturers, Online Examinations and Workshops to upgrade the knowledge of students for Competitive Examinations for the approval of the Academic Council.

N.V. Srinivasan
Chairman

University Nominee

Subject Expert

A. G & S. G Siddhartha Degree College of Arts and Science (Autonomous), Vuyyuru

(An Autonomous College in the jurisdiction of Krishna University, Machilipatnam)

NAAC reaccredited at 'A' level

*Autonomous -ISO 9001 – 2015 Certified***Title of the Paper: DESCRIPTIVE STATISTICS AND THEORY OF PROBABILITY****Semester: I**

Course Code	STATIIB	Course Delivery Method	Class Room / Blended Mode - Both
Credits	4	CIA Marks	25
No. of Lecture Hours / Week	4	Semester End Exam Marks	75
Total Number of Lecture Hours	60	Total Marks	100
Year of Introduction :2021-22	Year of Offering: 2021 - 22	Year of Revision: ----	Percentage of Revision: 0%

SEMESTER-1**PAPER - 1****No of Credits: 3**

S. No	PROGRAMME OUTCOMES
PO1	Remember the basic concepts of statistics at different levels and to understand them for gaining of knowledge.
PO2	Apply the statistical techniques in the analysis of data and also acquire knowledge in optimization techniques.
PO3	Facilitate students to acquire flair knowledge to estimate the values in real life problems.

COURSE OUTCOMES

CO.NO	Upon successful completion of this course, students should have the knowledge and skills to:	Mapping
CO1	knowledge of various types of data, their organization and evaluation of summary measures such as non- central and central moments , measures of skewness and kurtosis.	BTL2, PO2
CO2	knowledge to conceptualize the probabilities of events including frequentist and axiomatic approach. simultaneously, they will learn the notion of conditional probability including the concept of Bayes' Theorem,	BTL3, PO2
CO3	knowledge related to concept of discrete and continuous random variables and their probability distributions including expectation and moments,	BTL4, PO2
CO4	knowledge related to concept of generating functions and weak law of large numbers.	BTL4,PO2

About this Course

Statistics is an important field of math that is used to analyze, interpret, and predict outcomes from data. Descriptive statistics will teach you the basic concepts used to describe data. This is a great beginner course for those interested in Data Science, Economics, Psychology, Machine Learning, Sports analytics and just about any other field. This paper deals with the situation where there is uncertainty and how to measure that uncertainty by defining the probability.

A. G & S. G Siddhartha Degree College of Arts and Science (Autonomous), Vuyyuru
(An Autonomous College in the jurisdiction of Krishna University, Machilipatnam)

STATISTICS	STATIIB	2021-22 Onwards	B.Sc.(MSCs)
-------------------	----------------	------------------------	--------------------

SEMESTER-I **PAPER- I** **No. of Credits: 4**

DESCRIPTIVE STATISTICS AND THEORY OF PROBABILITY

Unit- I **12L**

Moments: Central and non-central moments and their inter-relationships, Sheppard's corrections for moments for grouped data. **Skewness:** Definition, measures of skewness by Karl Pearson's, Bowley's formulae and based on moments. **Kurtosis:** Definition, measures of kurtosis based on moments, Simple problems.

Unit- II **12L**

Probability-I: Definitions of various terms - Random experiments, trial, sample space, mutually exclusive, exhaustive, equally likely, favourable and independent events. Definitions-Mathematical, Statistical and Axiomatic definitions of probabilities. Law of addition of probabilities for two events and extension of general law of addition of probabilities. Boole's inequality for n events and real-life problems.

Unit -III **12L**

Probability-II : Conditional Probability-Definition - dependent and independence events, multiplication law of probability for two events, extension of multiplication law of probability. Pairwise independent events and conditions for mutual independence of n events and Baye's theorem and its applications and problems.

Unit- IV **12L**

Random Variables: Univariate Random variables- Definition, Discrete and Continuous random variables - Probability mass function and probability density function with illustrations. Distribution function and its properties. Bivariate random variables- Definition, Discrete and Continuous bi-variate random variables- joint, marginal and conditional distributions- its properties. Distribution functions of the bivariate random variables and its properties. Independence of random variables, and simple problems.

UnitV: **12L**

Mathematical Expectations: Definition, Mathematical expectation of function of a random variable, Properties of Expectations - Addition and Multiplication theorems of expectation. Properties of Variance and Covariance. Cauchy-Schwartz Inequality. Generating Functions- Definition of moment generating function (m.g.f), Cumulant generating function (c.g.f), Probability generating function (p.g.f) and Characteristic function (c.f) and statements of their properties with applications. Chebyshev's inequality and its applications. Statement of Weak Law of Large Numbers for identically and independently distributed (i.i.d) random variables with finite variance.

Text Book: Fundamentals of Mathematical Statistics, 12th Edition, 10th September 2020,

S. C. Gupta and V. K. Kapoor, Sultan Chand & Sons, New Delhi.

Recommended References books:

1. B.A/B.Sc. First Year Statistics(2010), Telugu Academy, Hyderabad.
2. Mathematical Statistics with Applications, 2009, K.M.Ramachandran and Chris P.Tsokos Academic Press(Elsevier), Haryana.
3. Probability and Statistics,Volume I, D.Biswas, New central book Agency (P) Ltd, New Delhi.
4. An outline of Statistical theory, Volume Two,3rd Edition,2010(with corrections) A.M.Goon,M.K. Gupta, B.Dasgupta ,The World Press Pvt.Ltd., Kolakota.
5. Sanjay Arora and Bansilal: New Mathematical Statistics, SatyaPrakashan, New Delhi.

Websites of Interest:

<http://onlinestatbook.com/rvls/index.html>

Co-Curricular Activities in the class:

1. Pictionary
2. Case Studies on topics in field of statistics
3. Snap test and Open Book test
4. Architectural - To be build the procedures
5. Extempore - Random concept to students
6. Interactive Sessions
7. Teaching through real world examples

Model Paper Structure

Section A: Answer FIVE questions out of EIGHT questions (5 x SM= 25 M)

Section B: Answer FIVE questions out of FIVE questions with internal choice .(5 x 10M = SOM)

A. G & S. G Siddhartha Degree College of Arts and Science (Autonomous), Vuyyuru
(An Autonomous College in the jurisdiction of Krishna University, Machilipatnam)

STATISTICS	STAT11B	2021-22 Onwards	B.Sc.(MSCs)
-------------------	----------------	------------------------	--------------------

Model Paper

Section-A

Answer any FIVE of the following

5 x 5 = 25Marks

1. Show that for discrete distributions $\beta_1 > 1$ **(L-2, C0-1)**
2. State and prove addition theorem of probability for two events **(L-1, C0-2)**
3. If A and B are independent events, then prove that **(L-3, C0-2)**
 $i) \overline{A \text{ and } B} \text{ and } \overline{A \text{ and } \overline{B}}$ are also independent
4. Define the "distribution function" (or cumulative distribution function) of a random variable and state its essential properties. **(L-2, C0-3)**
5. Explain the concepts marginal and conditional probability distributions. **(L-2, C0-3)**
6. Show that the mathematical expectation of the sum of two random variables is the sum of their individual expectations. **(L-3, C0-3)**
7. Define moment generating function (m.g.f.) of a random variable X. If $M_X(t)$ is the m.g.f. of a random variable X about the origin, show that the moment μ'_r is given by **(L-1, C0-4)**
$$\mu'_r = \left[\frac{d^r}{dt^r} M_X(t) \right]_{t=0}$$
8. Explain the concept of "weak law of large numbers". **(L-2, C0-4)**

Section- B

Answer ALL the questions

5 x 10 = 50 Marks

9. A) Define moments. Establish the relationship between the moments about mean, (Central moments) in terms of moments about any arbitrary point and vice versa. **(L-3, C0-1)**
(OR)
B) The scores in Statistics of 250 candidates appearing at an examination have Mean= 39.72, variance= 97.80, 3rd central moment and fourth central moments are -114.18 and 28,396.14. It was later found on scrutiny that the score 61 of a candidate has been wrongly recorded as 51. Make necessary corrections in the given values of the mean and the central moments. **(L-3, C0-1)**

10. A) State and Prove Boole's inequality. **(L-1, C0-2)**

(OR)

B) For two events A and B, prove that **(L-1, C0-2)**

(i) $P(A \cap B) = P(B) - P(A \setminus B)$ (ii) $P(A \cap B) = P(A) - P(A \setminus B)$

(iii) if $B \subseteq A$ then $P(A \cap B) = P(A) - P(B)$ (iv) If $A \subseteq B$ then $P(A \cap B) = P(B) - P(A)$

11. A) It is 8:5 against the wife who is 40 years old living till she is 70 and 4:3 against her husband now 50 living till he is 80. Find the probability that
 (i) Both will be alive, (ii) None will be alive,
 (iii) Only wife will be alive, (iv) Only husband will be alive,
 (v) Only one will be alive, (vi) At least one will be alive. **(L-3, C0-2)**

(OR)

B) A and B are two weak students of statistics and their chances of solving a problem in statistics correctly are 1/6 and 1/8 respectively. If the probability of their making a common error is 1/525 and they obtain the same answer, find the probability that their answer is correct. **(L-3, C0-2)**

12. A) Let X be a random variable with cumulative distribution function

$$F(x) = \begin{cases} 0, & \text{if } x < 0, \\ x^2 + 2 & \text{if } 0 \leq x < \frac{1}{2}, \\ 1 - \frac{1}{3} & \text{if } \frac{1}{2} \leq x < 1, \\ x + \frac{1}{8} & \text{if } 1 \leq x < 2, \\ x + 1 & \text{if } 2 \leq x < 3, \\ 1, & \text{if } x \geq 3 \end{cases}$$

Find

i) $P(0 \leq X < 1/4)$ (ii) $P(0 < X \leq 1/4)$ (iii) $P(0 \leq X \leq 1/4)$

(iv) $P(0 < X < 1)$ (v) $P(X = 3/4)$

(L-5, C0-3)

(OR)

B) Two discrete random variables X and Y have the joint probability density

function: $p(x, y) = \frac{Axe^{-x} p^y (1-p)^{y-x}}{y!(x-y)!}$, $y = 0, 1, 2, \dots$, $x = 0, 1, 2, \dots$

Where A, 1, > 0 & 0 < p < 1 are constants.

Find (i) The marginal probability density functions of X and Y.

(ii) The conditional distribution of Y for a given X and of X for a given Y.

(L-5, C0-3)

13. A) Explain the variance of a Linear Combination of Random Variables. **(L-2, C0-4)**

(OR)

B) (i) Define characteristic function of random variables and state its properties.

(ii) State and Prove Chebychev's inequality.

(L-2, C0-4)

A. G & S. G Siddhartha Degree College of Arts and Science (Autonomous), Vuyyuru
(An Autonomous College in the jurisdiction of Krishna University, Machilipatnam)

STATISTICS	STATIIB	2021-22 Onwards	B.Sc.(MSCs)
-------------------	----------------	------------------------	--------------------

SEMESTER-I

Practical - I: Descriptive Statistics

No of Credits: 1

CO.NO	Upon successful completion of this course, students should have the knowledge and skills to:	Mapping
CO1	draw the suitable diagram and graphs of the given sample data	P02
CO2	Analyze the uni-variate data using statistical techniques.	P02

List of Practicals

1. Diagrams & Graphs- Bar, Pie , Histogram, frequency polygon, and Ogive curves
2. Computation of measures of central tendency- Arithmetic Mean, Geometric mean and Harmonic Mean - Grouped Data.
3. Computation of measures of central tendency- Median, Mode and Partition Values - Grouped Data.
4. Computation of measures of Dispersion - Quartile Deviation, Mean Deviation, Standard Deviation, Variance and Coefficient of Variation - Grouped Data.
5. Computation of non-central, central moments, μ_1 and μ_2 and Sheppard's corrections for grouped data.
6. Computation of central moments, μ_1 and μ_2 and Sheppard's corrections when non -central moments are given.
7. Computation of Karl Pearson's coefficients, Bowley's coefficients of Skewness and coefficients of skewness based on moments - Grouped Data

Note: Training shall be on establishing formulae in Excel cells and derive the results. The excel output shall be exported to MS word for writing inference.

Reference Books

1. Practical Manual -Prepared by the Department Faculty Members
2. K.V.S. Sarma: Statistics Made Simple: Do it yourself on PC. PHI

Websites of Interest: <http://www.statsci.org/datasets.html>

**Adusumilli Gopalakrishnaiah & Sugarcane Growers
Siddhartha Degree College of Arts & Science
(Autonomous)**

Vuyyuru-521 165, Krishna District, A.P.

--00(--



Department of Environmental Studies

Minutes of the meeting of Board of Studies

29.11.2021

**Minutes of the meeting of Board of studies in Environmental Studies for the
Autonomous courses of AG & SG Siddhartha Degree College of Arts & Science,
Vuyyuru, held at 10.30 A.M on 29-11-2021 in the**

Department of ENVIRONMENTAL STUDIES

Sri R.V. Sivarao *Presiding*

Members Present:

- | | | |
|--|-----------------------|---|
| 1).....
(Sri.R.V. Sivarao) | Chairman | Head, Department of Environmental Studies
AG & SG S Degree College of Arts & Science
Vuyyuru-521165 |
| 2).....
(Dr.P.Brahmaji Rao) | University
Nominee | Dept of Environmental Science
Acharya Nagarjuna University
Guntur |
| 3).....
(Dr.K.Lakshmi) | Subject Expert | Dept of Zoology
S.D.M.Siddhartha Mahila Kalasala
Vijayawada. |
| 4).....
(V.Sailaja) | Subject Expert | Lecturer in Zoology
KTR Women's College
Gudiwada |

**Minutes of the meeting of Board of studies in Environmental Studies for the
Autonomous courses of AG & SG Siddhartha Degree College of Arts &
Science, Vuyyuru, held at 10.30 A.M on 29-11-2021 in the**

Department of ENVIRONMENTAL STUDIES

Sri R.V. Sivarao *Presiding*

Members Present:

- 1).....*R.V. Siva Rao*..... Chairman Head, Department of Environmental Studies
(Sri.R.V. Sivarao) AG & SG S Degree College of Arts & Science
Vuyyuru-521165

- 2).....*P. Brahmaji Rao*..... University Dept of Environmental Science
(Dr.P.Brahmaji Rao) Nominee Acharya Nagarjuna University
Guntur

- 3).....*K. Lakshmi*..... Subject Expert Dept of Zoology
(Dr.K.Lakshmi) S.D.M.Siddhartha Mahila Kalasala
Vijyawada.

- 4).....*V. Sailaja*..... Subject Expert Lecturer in Zoology
(V.Sailaja) KTR Women's College
Gudiwada

Agenda for B.O.S Meeting

- 1 .To recommend the syllabi for III, semester of 2nd Degree IInd year B.A, B.Com B.Sc , Environmental Education Paper Under CBCS for the Academic year 2021-2022
2. To recommend the Teaching and Evaluation Methods to be followed under Autonomous Status.
3. Any other matter.

RESOLUTIONS

- 1). Discussed and Recommended The Syllabi, Model Question Papers Under CBCS and Guidelines to be followed by the Question paper Setters of III Semester of II degree B.A,B.Com , B.Sc for the Approval of the Academic Council (enclosed) for the Academic year 2021– 2022.
- 2). Discussed and Recommended the Teaching and evaluation methods for approval of Academic Council.
 - A) Teaching methods:
Besides the conventional methods of teaching, it is also resolved to use various other methods like Group discussions, Quiz, for the better understanding of the contents.
 - B) Evaluation of a student is done by the following procedure:
 - a) There is no Internal Assessment Examinations.
 - b) Semester-End Examinations:
 - i) The maximum marks for Semester-End examinations shall be 50 and duration of the examination shall be 2 Hours.
 - ii) Semester-End examinations shall be conducted at the end of III semester.
- 3) Resolved to authorize the Chairman of Board of Studies to suggest the Panel of Paper setters and Examiners to the Controller of Examinations as per the requirement.

Chairman

ADUSUMILLI GOPALAKRISHNAIAH & SUGAR CANE GROWERS SIDDHARTHA DEGREE
COLLEGE OF ARTS & SCIENCE, VUYYURU-521165, KRISHNA Dt., A.P. (AUTONOMOUS).

ALLOCATION OF CREDITS

Structure of ENVIRONMENTAL EDUCATION Syllabus

For the Papers offered during I & III

<i>Year</i>	<i>Semester</i>	<i>Title</i>	<i>Teaching hours</i>	<i>Internal marks</i>	<i>External marks</i>	<i>Credits</i>
I	I	Environmental studies	10	10	40	2
	III	Environmental Education	30	---	50	2

Total Credits = 4



A.G & S.G.SIDDHARTHA DEGREE COLLEGE OF ARTS & SCIENCE

Vuyyuru-521165.

NAAC reaccredited at 'A' level

Autonomous -ISO 9001 – 2015 Certified

TITLE OF THE PAPER: ENVIRONMENTAL EDUCATION

Semester: III

Course Code	ENE-301	Course Delivery Method	Class Room / Blended Mode - Both
Credits	2	CIA Marks	-
No. of Lecture Hours / Week	2	Semester End Exam Marks	50
Total Number of Lecture Hours	30	Total Marks	50
Year of Introduction:	Year of Offering: 2021 - 22	Year of Revision: ----	Percentage of Revision: 0%
CLASS:	1ST YEAR BA/B.Com/BSc Programmes		

ENVIRONMENTAL EDUCATION

Common for BA/B.Com/BSc Programmes

Semester – III ENE-301

(Total 30 Hours)

Unit 1: Environment and Natural Resources 06 Hrs.

1. Multidisciplinary nature of environmental education; scope and importance. 2. Man as an integral product and part of the Nature. 3. A brief account of land, forest and water resources in India and their importance. 4. Biodiversity : Definition; importance of Biodiversity - ecological, consumptive, productive, social, ethical and moral, aesthetic, and option value. 5. Levels of Biodiversity: genetic, species and ecosystem diversity.

Unit-2: Environmental degradation and impacts 10Hrs

1. Human population growth and its impacts on environment; land use change, land degradation, soil erosion and desertification. 2. Use and over-exploitation of surface and ground water, construction of dams, floods, conflicts over water (within India). 3. Deforestation: Causes and effects due to expansion of agriculture, firewood, mining, forest fires and building of new habitats. 4. Non-renewable energy resources, their utilization and influences. 5. A brief account of air, water, soil and noise pollutions; Biological, industrial and solid wastes in urban areas. Human health and economic risks. 6. Green house effect - global warming; ocean acidification, ozone layer depletion, acid rains and impacts on human communities and agriculture. 7. Threats to biodiversity: Natural calamities, habitat destruction and fragmentation, over exploitation, hunting and poaching, introduction of exotic species, pollution, predator and pest control.

Unit 3: Conservation of Environment 10 Hrs

1. Concept of sustainability and sustainable development with judicious use of land, water and forest resources; afforestation. 2. Control measures for various types of pollution; use of renewable and alternate sources of energy. 3. Solid waste management: Control measures of urban and industrial waste. 4. Conservation of biodiversity: In-situ and ex-situ conservation of biodiversity. 5. Environment Laws: Environment Protection Act; Act; Wildlife Protection Act; Forest Conservation Act. 6. International agreements: Montreal and Kyoto protocols; Environmental movements: Bishnois of Rajasthan, Chipko, Silent valley.

Reference Books :

1. Environmental Studies by Dr.M.Satyanarayana, Dr.M.V.R.K.Narasimhacharyulu, Dr.G. Rambabu and Dr.V.VivekaVardhani, Published by Telugu Academy, Hyderabad.
2. Environmental Studies by R.C.Sharma, Gurbir Sangha, published by Kalyani Publishers.
3. Environmental Studies by Purnima Smarath, published by Kalyani Publishers.

AG&SG SIDDHARTHA DEGREE COLLEGE OF ARTS & SCIENCES –AUTONOMOUS

VUYYURU-521165

SEMESTER –III

MODEL QUESTION PAPER

COURSE CODE – ENE-301

Common for BA/B.Com/BSc Programmes

PAPER TITLE: ENVIRONMENTAL EDUCATION

DURATION :2 HOURS

SECTION – A

Max:50

ANSWER ANY FOUR OF THE FOLLOWING QUESTIONS

(4x5=20M)

1. Discuss about the Environmental Education.
2. What is Bio-Diversity
3. Deforestation
4. What is Global warming.
5. What is Ozone Layer
6. Forest Resources
7. Explain about Environmental laws
8. Write about Chipko Movement.

SECTION – B

ANSWER ANY THREE OF THE FOLLOWING QUESTIONS

(3x10=30M)

9. Write an essay on Forest Resource?
10. Explain the Scope and importance of Environmental Studies
11. Give an account of Renewable Energy Resource?
12. Write an essay on Air Pollution?
13. What is Sustainable Development?
14. Give an Account on Environmental Acts?

AG&SG SIDDHARTHA DEGREE COLLEGE OF ARTS & SCIENCES –AUTONOMOUS

VUYYURU-521165

The guidelines to be followed by the question paper setters in **ENVIRONMENTAL EDUCATION** for the 3rd semester – end exams (2021-22)

Common for BA/B.Com/BSc Programmes

PAPER TITLE: ENVIRONMENTAL EDUCATION

PAPER-I, SEMESTER – III

MAX :50

DURATION :2 HOURS

Weightage for the question paper

Marks	UNIT-I	UNIT-II	UNIT-III
	Environment and Natural Resources	Environmental degradation and impacts	Conservation of Environment
5Marks	2	3	3
10Marks	2	2	2
Weight age	30	25	25

AG & SG SIDDHARTHA COLLEGE OF ARTS AND SCIENCES - VUYYURU.

An Autonomous college within the jurisdiction of Krishna University A.P, India.

(With Effect from Academic Year 2021-22)

Title of the Paper: **Computer Fundamentals and Office Tools**

Semester: I

Course Code	LSC002	Course Delivery Method	Class Room / Blended Mode - Both
Credits	2	CIA Marks	0
No. of Lecture Hours / Week	2	Semester End Exam Marks	50
Total Number of Lecture Hours	30	Total Marks	50
Year of Introduction :2020-21	Year of Offering: 2021 - 22	Year of Revision: Nil	Percentage of Revision: 0%

COURSE OBJECTIVES: This course aims at providing exposure to students in skill development towards basic office applications.

CO1: Able to learn the basic features characteristics, applications of computer and introduction about windows operating system.

CO2: Able to learn the basic technicalities of creating Writer documents and presentations

CO3: Able to learn how to design a Calc Spreadsheet for general office.

Unit-I: Basics of Computers and Operating Systems

Basics of Computers : Definition of a Computer - Characteristics and Applications of Computers – Block Diagram of a Digital Computer – Classification of Computers based on size and working – Central Processing Unit – I/O Devices. Memory Devices- Primary, Auxiliary and Cache Memory.

Operating Systems: Definition and Types of Operating System – Functions of an Operating System – MS Windows – Desktop, Computer, Documents, Pictures, Music, Videos, Recycle Bin, Task Bar – Control Pane.

Unit-II: Writer Document and Impress Presentation

Writer Document : Features of Writer – Writer Window Components – Creating, Editing, Formatting and Printing of Documents – Headers and Footers – Insert/Draw Tables, Table Auto format – Page Borders and Shading – Inserting Symbols, Shapes, Gallery, Page Numbers, Equations – Spelling and Grammar – Mail Merge

Impress Presentation: Features of Impress Presentation – Creating a Blank Presentation - Creating a Presentation using a Template - Inserting and Deleting Slides in a Presentation – Adding Clip Art/Pictures - Inserting Other Objects, Audio, Video - Resizing and Scaling of an Object – Slide Transition – Animation

Unit-III: Calc Spreadsheet

Overview of Calc features – Creating a new worksheet, Selecting cells, Entering and editing Text, Numbers, Formulae, Referencing cells – Inserting Rows/Columns – Changing column widths and row heights, auto format, changing font sizes, colors, shading.

Reference Books:

1. Fundamentals of Computers by Reema Thareja, Publishers : Oxford University Press, India
2. Fundamentals of Computers by V.Raja Raman, Publishers : PHI
3. Getting Started Guide Libreoffice 5.0

<https://www.libreoffice.org/assets/Uploads/Documentation/GS51-GettingStartedLO.pdf>

AG & SG SIDDHARTHA COLLEGE OF ARTS AND SCIENCES - VUYYURU.
An Autonomous college within the jurisdiction of Krishna University A.P, India.
(With Effect from Academic Year 2021-22)

MODEL Question Paper:

PAPER TITLE: Computer Fundamentals and Office Tools COURSE CODE: LSC002

SEMESTER: I

TIME: 2 Hrs.

MAX: 50M

SECTION – A

(Total: 4x5=20 Marks)

Answer any **four questions**. Each answer carries **5 marks**

- 1.
- 2.
- 3.
- 4.
- 5.
- 6.
- 7.
- 8.

SECTION – B

(Total: 3x10 = 30 Marks)

(Answer any **three questions**. Each answer carries **10 marks**)

- 1.
- 2.
- 3.
- 4.
- 5.

**ADUSUMILLI GOPALAKRISHNAIAH & SUGAR CANE GROWERS SIDDHARTHA DEGREE COLLEGE
OF ARTS & SCIENCE, VUYYURU-521165, KRISHNA Dt., A.P. (AUTONOMOUS).**

NACC reaccredited at 'A' level
Autonomous –ISO 9001-2015 Certified

Title of the Paper: **Environmental Studies.**

Semester: - I

Course Code		Course Delivery Method	Class Room/Blended Mode - Both
Credits	2	CIA Marks	10
No. of Lecture Hours/ Week	10	Semester End Exam Marks	40
Total Number of Lecture Hours	30	Total Marks	50
Year of Introduction : 2021	Year of Offering 2021-2022	Year of Revision – 2021-22	Percentage of Revision: 0%

LIFE SKIL COURSE	CLAC001	2021-2022	B.A., B.Com., A.B.C., & B.Sc
-------------------------	----------------	------------------	---

CO1: Realize the importance of environment, the goods and services of a healthy biodiversity, dependence of humans on environment.

CO2: Evaluate the ways and ill effects of destruction of environment, population explosion on ecosystems and global problems consequent to anthropogenic activities.

CO3: Discuss the laws/ acts made by government for environmental conservation and acquaint with international agreements and national movements and realize citizen's role in protecting environment and nature.

Syllabus
Course Details

Unit	Learning Units	Lecture Hours
I	<p>Unit 1: Environment and Natural Resources Multidisciplinary nature of environmental education. Scope and importance of environmental education. A brief account of forest, water and renewable energy resources. Biodiversity introduction, Levels of Biodiversity: genetic, species and ecosystem diversity. Concept, Structure and functions of an Ecosystem.</p>	8
II	<p>Unit 2 : Environmental degradation and Impacts Threats to Biodiversity: Natural calamities, habitat destruction and fragmentation, over exploitation, hunting and poaching, introduction of exotic species, pollution, predator and pest control. A brief account of causes and effects of Air, Water, Soil and Noise pollution. Non-renewable energy resources, their utilization and influences. Climate change, Global warming, Acid rains, Ozone depletion. Human population growth and its impacts on environment; land use change, land degradation, soil erosion and desertification.</p>	12
III	<p>Unit 3: Conservation of Environment Conservation of biodiversity: In-situ and ex-situ conservation of biodiversity. Control measures for various types of pollution; use of renewable and alternate sources of energy. Solid waste management- Measures for safe urban and Industrial wastes disposal. Environment Laws: Environment Protection Act; Wildlife Protection Act; Forest Conservation Act. International agreements: Montreal and Kyoto protocols. Environmental movements: Bishnois of Rajasthan, Chipko, Silent valley.</p>	10

Suggested activities to learner:

1. Visit to a local polluted site-Urban/Rural/Industrial/Agricultural site.
2. Visit to a local waste disposal/ land filling site

Reference Books :

1. Environmental Studies by Dr.M.Satyanarayana, Dr.M.V.R.K.Narasimhacharyulu, Dr.G. Rambabu and Dr.V.VivekaVardhani, Published by Telugu Academy, Hyderabad.
2. Environmental Studies by R.C.Sharma, Gurbir Sangha, published by Kalyani Publishers.
3. Environmental Studies by Purnima Smarath, published by Kalyani Publishers

MODEL PAPER
AEC002 /HRDMM/

Title of the paper: Environmental Studies.

No. of Pages:-1.

Time: 2 Hrs

No. of Questions: 16

Max. Marks: 40M

Pass min. 16M

SECTION –A

Answer any FOUR of the following:

4x7=28 M

1. Explain the scope and importance of environmental studies?
- . .
2. Give an account of renewable energy resources?
- . .
3. Define ecosystem. Explain the structural components of an ecosystem?
- . .
4. Define biodiversity. Explain various strategies for its conservation?
- . .
5. Explain the causes, effects and control measures of air pollution?
- . .
6. Give an account on environmental acts?

SECTION –B

Answer any SIX of the following:

6x2=12 M

7. Deforestation.
8. Chipko movement
9. Food chain
10. Biodiversity Hotspots
11. Poaching
12. Floods
13. Earthquakes
14. Rainwater harvesting
15. Global warming
16. Population explosion

**ADUSUMILLI GOPALAKRISHNAIAH & SUGAR CANE GROWERS SIDDHARTHA DEGREE COLLEGE
OF ARTS & SCIENCE, VUYYURU-521165, KRISHNA Dt., A.P. (AUTONOMOUS).**

NACC reaccredited at 'A' level
Autonomous –ISO 9001-2015 Certified

Title of the Paper: **Poultry Farming**

Semester: - III

Course Code	PF-301	Course Delivery Method	Class Room/Blended Mode - Both
Credits	2	CIA Marks	00
No. of Lecture Hours/ Week	10	Semester End Exam Marks	50
Total Number of Lecture Hours	30	Total Marks	50
Year of Introduction :	Year of Offering 2021-2022	Year of Revision – 2021-22	Percentage of Revision: 0%

SKILL DEVELOPMENT COURSE	Course code: PF-301	2021-2022	A.B.C., & B.Sc
---------------------------------	------------------------	------------------	---------------------------

Learning Outcomes:

By successful completion of the course, students will be able to;

1. Understand the field level structure and functioning of insurance sector and its role in protecting the risks
2. Comprehend pertaining skills and their application for promoting insurance coverage
3. Prepare better for the Insurance Agent examination conducted by IRDA
4. Plan 'promoting insurance coverage practice' as one of the career options.

Syllabus
Course Details

Unit	Learning Units	Lecture Hours
I	<p>Section I (Introduction to Poultry Farming): General introduction to poultry farming -Definition of Poultry; past and present scenario of poultry industry in India. Principles of poultry housing. Poultry houses. Systems of poultry farming. Management of chicks, growers and layers. Management of Broilers. Preparation of project report for banking and insurance</p>	10
II	<p>Section II (Feed and Livestock Health Management): Poultry feed management – Principles of feeding, Nutrient requirements for different stages of layers and broilers. Feed formulation and Methods of feeding. Poultry diseases – viral, bacterial, fungal and parasitic (two each); symptoms, control and management; Vaccination programme.</p>	10
III	<p>Section III (Harvesting of Eggs and Sanitation): Selection, care and handling of hatching eggs. Egg testing .Methods of hatching. Brooding and rearing. Sexing of chicks. Farm and Water Hygiene, Recycling of poultry waste.</p>	10

Co- Curricular Activities suggested:

(4 Hrs)

1. Group discussion & SWOT analysis
2. Visit to a poultry farm
3. Invited Lectures by Concerned officers of government or private farms
4. Cheap and Healthy Feed preparation by students based on government standards
5. Market study and Survey (Monitoring of daily price hike in poultry market and analysis)
6. Online Swayam Moocs course on poultry farming (see reference 9 below)

Reference books:

1. Sreenivasaiah., P. V., 2015. Textbook of Poultry Science. 1st Edition. Write & Print Publications, New Delhi
2. Jull A. Morley, 2007. Successful Poultry Management. 2nd Edition. Biotech Books, New Delhi"

Semester –III

w.e.f. 2021-2022

Time: 90 mins

(Model question paper)

Title of the paper: Poultry Farming.

Code – PF- 301(SDC)

max.marks: 50

Section – A

Answer any **four** questions. Each question carries **five** marks.

4 x 5= 20.

1. Poultry house
2. Broilers
3. Any two viral diseases of poultry
4. Any two bacterial diseases of poultry
5. Any two fungal diseases of poultry
6. Egg testing
7. Brooding
8. Sexing chicks

Section – B

Answer any **three** questions. Each question carries **Ten** marks.

3 x 10 =30

9. Discuss briefly the past, present and future scenario of poultry farming industry in India
10. Explain principles of poultry housing in detail, with examples.
11. Write an essay on viral diseases of poultry.
12. Give an account of fungal and bacterial diseases (any two each) of poultry
13. Write an essay on selection, handling and hatching of eggs.

SEMESTER-III
SKILL DEVELOPMENT COURSE

Guide lines to the paper setter

Time: 1½ hrs

Max.Marks:50

Paper Title: - Poultry Farming.

Paper Code: PF-301 (SDC)

Note: 1. Answer **any four** questions out of eight in Part-A. Each question carries five marks. 4X 5 = 20M.

2. Answer any **three** questions out of five in Part-B. Each question carries 10 marks. 3 X 10 = 30M.

	PART	Unit –I	Unit – II	Unit-III
5 Marks Questions	A	2	3	3
10 Marks Questions	B	2	2	1
Weightage		30	35	25

- Note:**
1. please provide the scheme of valuation for the paper.
 2. Question paper should be both in English and Telugu media.

**A.G & S.G SIDDHARTHA DEGREE COLLEGE OF ARTS AND SCIENCE,
VUYYURU-521165, KRISHNA Dt, A.P.**
(An Autonomous College in the jurisdiction of Krishna University, Machilipatnam)
Accredited with “A” Grade by NAAC, Bengaluru

Title of the Paper: Analytical Skills

Semester: III

Course Code	ANS - 301	Course Delivery Method	Class Room / Blended Mode - Both
Credits	2	CIA Marks	0
No. of Lecture Hours / Week	2	Semester End Exam Marks	50
Total Number of Lecture Hours	30	Total Marks	50
Year of Introduction :2021-22	Year of Offering: 2021 - 22	Year of Revision: ----	Percentage of Revision: 0%

Course Objective: Intended to inculcate quantitative analytical skills and reasoning as an inherent ability in students.

Course Outcomes:

After successful completion of this course, the student will be able to;

- 1) Understand the basic concepts of arithmetic ability, quantitative ability, logical reasoning, business computations and data interpretation and obtain the associated Skills.
- 2) Acquire competency in the use of verbal reasoning.
- 3) Apply the skills and competencies acquired in the related areas
- 4) Solve problems pertaining to quantitative ability, logical reasoning and verbal ability inside and outside the campus.

UNIT – 1

6 Hrs

Test of Reasoning – I:-Coding – Decoding, Direction Test, Interchange of Signs, Logical Venn diagrams, Series Puzzles.

UNIT – 2

6 Hrs

Test of Reasoning – II: - Analogies of numbers and Alphabets completion of blank spaces following the pattern in A: B: C: D relationship odd thing out; Missing number in a sequence or a series.

UNIT – 3

6 Hrs

Arithmetic ability:-Algebraic operations BODMAS, Fractions, Divisibility rules, LCM and GCD (HCF).

Date, Time and Arrangement Problems: Calendar Problems, Clock Problems, Blood Relationship.

UNIT – 4

6 Hrs

Quantitative aptitude: - Averages, Ration and proportion, Problems on ages, Time-distance-speed.

UNIT – 5

6 Hrs

Business computations:- Percentages, Profit & loss, Partnership, simple, compound interest.

Reference Books:

1. Quantitative Aptitude for Competitive Examination by R S Agrawal, S.Chand publications.
2. Quantitative Aptitude and Reasoning by R V Praveen, PHI publishers.
3. Quantitative Aptitude: Numerical Ability (Fully Solved) Objective Questions, Kiran Prakashan, Pratogitaprakasan, Kic X, Kiran Prakasan publishers
4. Quantitative Aptitude for Competitive Examination by Abhijit Guha, Tata Mc Graw hill Publications.
5. Old question Paper of the exams conducted by (Wipro, TCS, Infosys, Etc) at their recruitment process, source-Internet.

**A.G & S.G SIDDHARTHA DEGREE COLLEGE OF ARTS AND SCIENCE VUYYURU-
521165**

(An Autonomous College in the jurisdiction of Krishna University, Machilipatnam)

Accredited with “A” Grade by NAAC, Bengaluru

DEPARTMENT OF MATHEMATICS

Analytical Skills

Time: 2 Hrs

Code: ANS – 301

Max. Marks: 50

Min. Marks: 20

Guidelines for Paper setter

To be set all the questions are “Multiple Choice” with four (or) five options.

Section – A

Unit – 1:- Ten questions. Each question carries **ONE** mark 10x1=10M

Unit – 2:- Ten questions. Each question carries **ONE** mark 10x1=10M

Section – B

Unit – 3:- Five questions. Each question carries **TWO** mark 5x2=10M

Unit – 4:- Five questions. Each question carries **TWO** mark 5x2=10M

Unit – 5:- Five questions. Each question carries **TWO** mark 5x2=10M

A.G & S.G SIDDHARTHA DEGREE COLLEGE OF ARTS AND SCIENCE: VUYYURU

(An Autonomous College in the jurisdiction of Krishna University, Machilipatnam)

Accredited with “A” Grade by NAAC, Bengaluru

DEPARTMENT OF MATHEMATICS

Analytical Skills Model Paper(w.e.f.2021 – 22)

Time: 2 Hrs

ANS – 301









Max.Marks:50

Min. Marks: 20

Section – A

I Answer the following questions.

20x1 = 20 M

- 1) In a certain code KNIFL is coded as IFLKN, how is DOCTOR coded as? []
a) ROTCOD b) TORDOC c) CTORDO d) ROTDOC e) CODTOR
- 2) In a certain code HUMIDITY is coded as UHIMIDTY, how is POLITICS coded as?[]
a) OPILITCS b) OPILITCS c) OPLITISC d) POLITISC e) NONE
- 3) A man walks 1km towards East and then he turns to South and walks 5km. Again he turns to East and walks 2km. After this, he turns to North and walks 9km. Now how far is he from his starting point? []
a) 3km b) 4km c) 5km d) 7km e) None
- 4) A cyclist goes 30km to North and then turning to East he goes 40km. Again he turns to his right and goes 20km. After this, he turns to his right and goes 40km. How far is he from his starting point? []
a) 0km b) 10km c) 25km d) 40km e) 50km
- 5) If + means \div , - means +, x means - and \div means x, then $8 \div 4 - 6 + 3 \times 4 = ?$ []
a) 8 b) 46 c) 4 d) 13 e) None
- 6) If A stands for +, B stands for -, C stands for x, what is the value of $(10C4)A(4C4)B6?$ []
a) 46 b) 50 c) 56 d) 60 e) None
- 7) Which of the following diagram shows the relationship amongst Husband, Wife, Family[]
a)  b)  c)  d)  e) None
- 8) Which of the following diagram shows the relationship amongst English, Latin, Greek[]
a)  b)  c)  d)  e) None
- 9) $ABD : EFH :: IJL : \text{-----}$. []
a) MNP b) MPN c) NMP d) NMT e) None
- 10) $ABE : 8 :: FBD : \text{-----}$. []
a) 14 b) 13 c) 12 d) 15 e) None
- 11) Find the missing term of the series 2, 15, 41, 80, 132, _____. []
a) 111 b) 120 c) 121 d) 197 e) 215
- 12) Find the missing term of the series 8, 16, 28, 44, _____. []
a) 62 b) 64 c) 66 d) 60 e) 75

- 13) Find the missing term of the series 4, 125, 225, _____, 370, 419. []
 a) 300 b) 295 c) 306 d) 355 e) 315
- 14) Find the wrong number in the series 1, 8, 27, 64, 125, 215? []
 a) 8 b) 27 c) 1 d) 215 e) 125
- 15) Find the wrong number in the series 10, 14, 27, 32, 64, 68, 136? []
 a) 14 b) 27 c) 32 d) 68 e) 136
- 16) Find the missing letter of the series W, T, P, M, I, F, B, _____. []
 a) Z b) X c) U d) Y e) V
- 17) Find the missing letters of the series NZ, OY, PX, QW, RV, _____. []
 a) FS b) SU c) UF d) TU e) SV
- 18) AFL, JOR, MRU, _____? []
 a) GJN b) HMP c) PMO d) RJL e) TUA
- 19) ABD : EFH :: IJL : ----- []
 a) MNP b) MPN c) NMP d) NMT e) None
- 20) ABE : 8 :: FBD : ----- []
 a) 14 b) 13 c) 12 d) 15 e) None

Section – B

II Answer the following questions.

15x2 = 30 M

- 21) Simplify $18 - [5 - \{6 + 2(7 - (8 - 5))\}]$ []
 a) 13 b) 15 c) 27 d) 32 e) None
- 22) Find the H.C.F of 108, 288 and 360. []
 a) 28 b) 32 c) 33 d) 36 e) 39
- 23) What was the day of the week on 15th August 1947? []
 a) Monday b) Wednesday c) Thursday d) Friday e) None
- 24) What is the angle between two hands of a clock at 3:25? []
 a) 45° b) $46\frac{1}{2}^\circ$ c) $47\frac{1}{2}^\circ$ d) 48° e) None
- 25) If B says that his mother is the only daughter of A's mother, then what is the relation of A with B? []
 a) Son b) Father c) Uncle d) Brother e) None
- 26) What is the average of first 40 natural numbers? []
 a) 19 b) 20.5 c) 22 d) 23.5 e) 24
- 27) If $a:b = 5:9$ and $b:c = 4:7$, find $a:b:c$? []
 a) 20:36:63 b) 25:35:45 c) 25:36:49 d) 20:49:81 e) None
- 28) If $x:y = 3:4$, find $(4x+5y) : (5x-2y)$ []
 a) $\frac{20}{7}$ b) $\frac{32}{7}$ c) $\frac{40}{7}$ d) $\frac{47}{7}$ e) None

- 29) Rajeev's age after 15 years will be 5 times his age 5 years back. What is the present age of Rajeev? []
a) 12 years b) 13years c) 10 years d) 14 years e) 11 years
- 30) How many minutes does Aditya take to cover a distance of 400m, if he runs at a speed of 20 km/hr? []
a) $1\frac{1}{5}$ Min b) $1\frac{1}{8}$ Min c) $1\frac{1}{7}$ Min d) $1\frac{1}{6}$ Min e) $1\frac{1}{9}$ Min
- 31) Evaluate 28% of 450 + 45 of 280 []
a) 315 b) 252 c) 275 d) 280 e) 298
- 32) A man buys an article for Rs 27.50 and sells it for Rs 28.60. []
Find his gain percent.
a) 5% b) 3% c) 4% d) 6% e) None
- 33) Anand and Deepak started a business investing Rs 22,500 and 35,000 respectively. Out of a total profit of Rs 13,800, Deepak's share is? []
a) Rs 5400 b) Rs 7200 c) Rs8400 d) Rs9600 e) Rs6500
- 34) Find the simple interest on Rs 68,000 at $16\frac{2}{3}$ % per annum for 9 months. []
a) Rs 8500 b)Rs 6800 c) Rs 7500 d) Rs 9000 e) None
- 35) Find compound interest on Rs 7500 at 4% per annum for 2 years. []
a) Rs 530 b) Rs 600 c) Rs 612 d) Rs 680 e) Rs 710



A. G & S.G. SIDDHARTHA DEGREE COLLEGE OF ARTS & SCIENCE

Vuyyuru-521165.

NAAC reaccredited at 'A' level

Autonomous -ISO 9001 – 2015 Certified

TITLE OF THE PAPER: ONLINE BUSSIENESS

Semester: III

Course Code	COB-301G/C	Course Delivery Method	Class Room / Blended Mode - Both
Credits	2	CIA Marks	---
No. of Lecture Hours / Week	2	Semester End Exam Marks	50
Total Number of Lecture Hours	30	Total Marks	100
Year of Introduction:	Year of Offering: 2021 - 22	Year of Revision: ----	Percentage of Revision: 0%
Class:	I.BCom., (gen/comp)		

Learning Outcomes:

After successful completion of the course, students will be able to;

1. Understand the online business and its advantages and disadvantages
2. Recognize new channels of marketing, their scope and steps involved
3. Analyze the procurement, payment process, security and shipping in online business
4. Create new marketing tools for online business
5. Define search engine, payment gateways and SEO techniques.

Course Details**Syllabus
ONLINE BUSSINESS**

Unit	Learning Units	Lecture Hours
I	Introduction to Online-Business-Definition-Characteristics-Advantages of Online Business-Challenges- Differences between off-line business, e-commerce and Online Business.	10
II	Online-business Strategies-Strategic Planning Process-Procurement -Logistics & Supply Chain Management- Customer Relationship management.	10
III	Designing Online Business Website – Policies - Security & Legal Issues - Online Advertisements - Payment Gateways - Case Study	10

Co-curricular Activities Suggested: (4 hrs)

1. Assignments, Group discussion, Quiz etc.
2. Short practical training in computer lab
3. Identifying online business firms through internet
4. Invited Lectures by e-commerce operators
5. Working with Google and HTML advertisements.
6. Visit to a local online business firm.



A. G & S.G. SIDDHARTHA DEGREE COLLEGE OF ARTS & SCIENCE

Vuyyuru-521165.

**NAAC recredited at 'A' level
Autonomous -ISO 9001 – 2015 Certified**

TITLE OF THE PAPER: ONLINE BUSSINESS

Semester: III

DURATION: 2 HOURS

SECTION – A

Max:50

ANSWER ANY FOUR OF THE FOLLOWING QUESTIONS

(4x5=20M)

1. Define Online Business
2. Explain Charters tics of Online Business
3. E-Commerce
4. Online Business strategies
5. Supply Chain Management
6. Customer Relationship Management
7. Legal issues of Online Business
8. Online Adverting

SECTION – B

ANSWER ANY THREE OF THE FOLLOWING QUESTIONS

(3x10=30M)

9. Explain the Advantages of Online Business?
10. What are the differences between Offline and Online Business?
11. Explain about Online Business Strategic planning process
12. Describe Online Business Strategic Planning process
13. How do you Design Online Business Website
14. Describe the Polices of Online Business



A. G & S.G. SIDDHARTHA DEGREE COLLEGE OF ARTS & SCIENCE

Vuyyuru-521165.

NAAC reaccredited at 'A' level
Autonomous -ISO 9001 – 2015 Certified

TITLE OF THE PAPER: ONLINE BUSSINESS

Semester: III

Guidelines to the paper setter

Marks	UNIT-I	UNIT-II	UNIT-III
	Introduction Online business	Online business Strategies	Designing Online Business Website
5Marks	3	3	2
10Marks	2	2	2
Weight age	35	35	30



A. G & S.G. SIDDHARTHA DEGREE COLLEGE OF ARTS & SCIENCE

Vuyyuru-521165.

NAAC reaccredited at 'A' level

Autonomous -ISO 9001 – 2015 Certified

TITLE OF THE PAPER:FINANCIAL MARKETS

Semester: III

Course Code	FM-301	Course Delivery Method	Class Room / Blended Mode - Both
Credits	2	CIA Marks	Nil
No. of Lecture Hours / Week	2	Semester End Exam Marks	50
Total Number of Lecture Hours	30	Total Marks	50
Year of Introduction:	Year of Offering: 2021 - 22	Year of Revision: ----	Percentage of Revision: 0%
CLASS:	II.B.A		

Learning Outcomes:

After successful completion of this course, the students will be able to;

1. Acquire knowledge of financial terms
2. Know the concepts relating to and markets and different avenues of investment
3. Understand the career skills related to Stock Exchanges
4. Comprehend the personal financial planning and money market skills

SKILL DEVELOPMENT COURSES
ARTS STREAM
Syllabus of
FINANCIAL MARKETS

UNIT-I: 06hrs

Indian Financial System- its components - Financial markets and institutions

UNIT-II: 10hrs

Capital Market - its function - organizations - elements - (shares, debentures, bonds, mutual funds) debt market - Equity market (SEBI) and secondary market (NSE)

UNIT-III: 10hrs

Money market - Organized - Unorganized - Sub market (call money, commercial bills, Treasury bill, Certificate of Deposit, Commercial papers)

Co-curricular activities: (04 hrs)

1. Collection and study of pamphlets, application forms etc.
2. Invited lectures on the field topics by local experts
3. Introducing Online classes from NSE
4. Field visit to mutual fund offices/share brokers
5. Observation, study and analysis of selected companies share prices
6. Assignments, Group discussion, quiz etc.

Reference books:

1. T.R. Jain R.L.Sarma - Indian Financial System- VK Global publisher
2. Jithendra Gala - Guide to Indian Stock markets Buzzing Stock publishing house
3. Saha Siddhartha- Indian financial System- and Markets - McGraw hill
4. Websites on Indian Financial markets.

A.G. & S.G.SIDDHARTHA DEGREE COLLEGE OF ARTS & SCIENCE
(AUTONOMOUS), (2021 - 2022) VUYYURU

MODEL QUESTION PAPER FORMAT

Max. Marks: 50

Time: 2hrs (90 Minutes)

SECTION A (Total: 4x5=20 Marks)

(Answer any four questions. Each answer carries 5 marks)

1. Objectives of financial system.
2. Functions of financial markets.
3. Difference between primary and secondary Market.
4. Differences between Debt market and Equity market.
5. Methods of floatation of securities in primary market.
6. Commercial bill market.
7. Role of RBI in the commercial paper market.
8. Types of bills in money market.

SECTION B (Total: 3x10 = 30 Marks)

(Answer any three questions. Each answer carries 10 marks)

1. Explain the classification of financial markets.
2. Describe the Role of financial system in Economic Development.
3. Define capital Market? Explain its characteristics?
4. Write about National Stock Exchange of India limited (NSE).
5. Define Money Market? Explain the characteristics, objectives and functions of money market.
6. Explain the challenges of Indian money market and describe measures to improve Indian money market.

A.G. & S.G.SIDDHARTHA DEGREE COLLEGE OF ARTS & SCIENCE
(AUTONOMOUS), (2021 - 2022) VUYYURU

The Guidelines to be followed by the question paper setters in FINANCIAL
MARKETS for the III Semester – End Examinations (2021 - 2022)

PAPER TITLE :FINANCIAL MARKETS

Paper- S.D.C Semester – III Maximum marks : 50 Duration : 2Hours

Weightage for the question paper

Syllabus	Section-A (Short answer questions)	Section-B (Essay questions)
Unit-1 (30Marks)	2	2
Unit-2 (35Marks)	3	2
Unit-3 (35Marks)	3	2
Total 100	40	60

- 1.Each question carries 5 marks in Section-A
- 2.Each Essay question carries 10 marks in Section –B
3. The Question papers setters are requested to cover all the topics in the syllabus stipulated as per the weightage given by us